

# RAČUNALNIŠKA MIZA / SCHRANK / STORE CABINET

## NAVODILA ZA SESTAVO / ASSEMBLY INSTRUCTION / AUFBAUANLEITUNG

- Hvala za nakup enega od naših izdelkov. Prosimo, da pred sestavljanjem preberete pozorno Navodila za sestavo (Pozor: ne zategnite vijakov preden so vsi nameščeni v luknje).
- Vielen Dank für den Kauf eines unserer Produkte. Bitte lesen Sie die Aufbauanleitung sorgfältig bevor Sie das Produkt aufbauen. Achtung: Bitte die Schrauben erst festziehen wenn alle Schrauben eingesetzt sind.
- Thanks for purchasing one of our products, please read carefully the assembly instructions before the installation (Attention: Do not tighten the screws before all screws are in place).

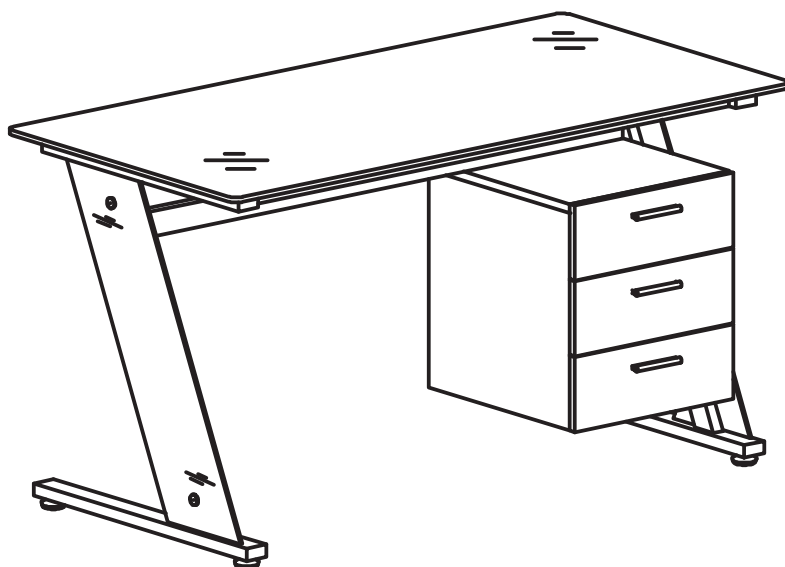

**POTREBNI STA 2 OSEBI**  
ZWEI PERSONEN ERFORDERLICH  
TWO PEOPLE REQUIRED

**MODEL BLANCO**

### **SPLOŠNA NAVODILA**

-Pohištvo naj ne bo nameščeno direktno na svetlobi. Uporabite mizno podlago za zaščito površine pred vdrtinami, praskami in vročimi ali mrzlimi tekočinami.

#### **Čiščenje:**

- Za čiščenje površin uporabite vlažno (ne mokro) krpo ali suho bombažno krpo.
- Za čiščenje steklenih površin lahko uporabite čistilo za okna.

#### **Allgemeiner Hinweis:**

-Setzen Sie die Möbel keinem direkten Sonnenlicht aus und nutzen Sie Unterlagen und Untersetzer um den Untergrund vor Dellen, Kratzern und Feuchtigkeit zu schützen.

#### **Reinigung:**

- Zur Reinigung der Oberfläche, nutzen Sie ein feuchtes (nicht nasses) Tuch oder verwenden Sie ein sauberes Baumwolltuch.
- Fensterreiniger oder vergleichbare Mittel können für die Reinigung von Glasflächen verwendet werden.

#### **General Care:**

-Keep your furniture out direct sunlight-Use desk pads and coasters to protect the surface from dents, scratches, and moisture from hot or cold liquids.



#### **Cleaning:**

- For cleaning, wipe the surface with a damp (not wet) cloth or wipe dry with a clean lint free cotton cloth.
- Window cleaning liquid or a similar cleaning liquid can be used to clean glass surface.

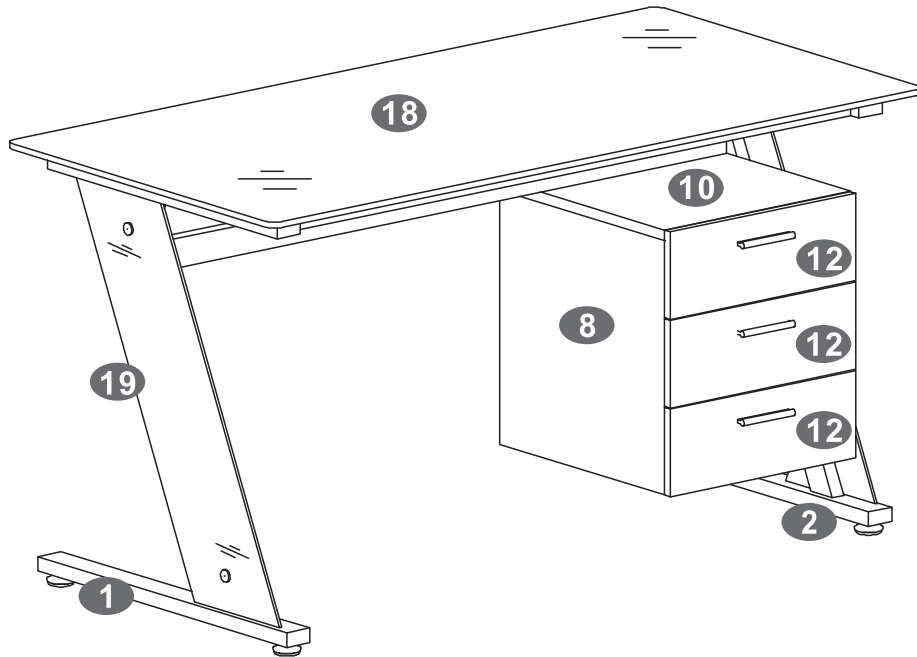

■ SESTAVNI DELI / TEILE ÜBERSICHT / PARTS LIST

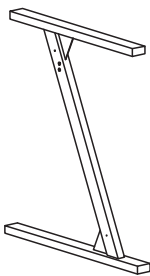
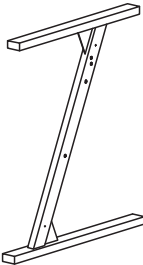
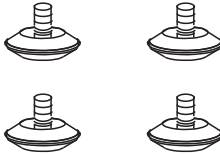

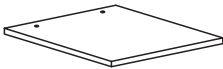
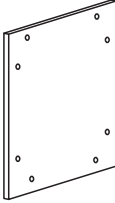
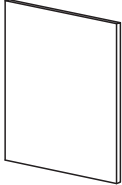
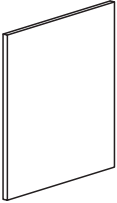
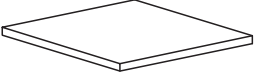
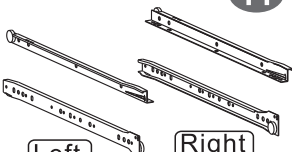
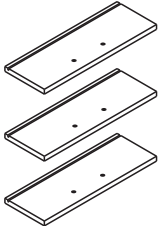

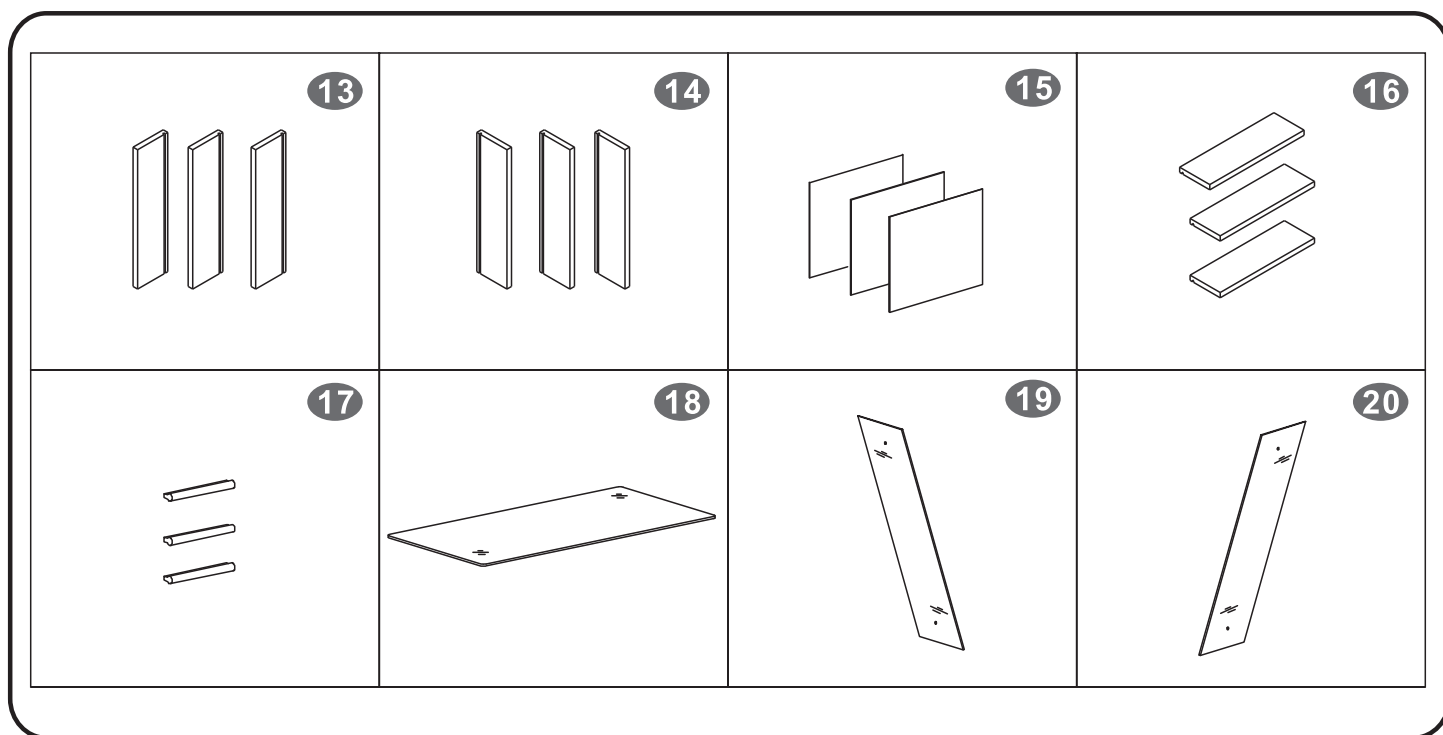
 <p>1</p>	 <p>2</p>	 <p>3</p>	 <p>4</p>
 <p>5</p>	 <p>6</p>	 <p>7</p>	 <p>8</p>
 <p>9</p>	 <p>10</p>	 <p>Left LEVO links</p> <p>Right DESNO recht</p> <p><b>3 SETI</b></p>	 <p>12</p>



▪ LISTA VIJAKOV / SCHRAUBEN-LISTE / SCREWS LIST

DEL DEI PART	KOLI MENGE QTY.	ART. ARTIKEL ITEM		DEL DEI PART	KOLI MENGE QTY.	ART. ARTIKEL ITEM	
<b>A</b>	24	3X15 MM		<b>J</b>	4	4X16 MM	
<b>B</b>	16	6X40 MM		<b>K</b>	4		
<b>C</b>	2	6X75 MM		<b>L</b>	12	6X25 MM	
<b>D</b>	4	6X65 MM			1		
<b>E</b>	12	4X35 MM			1		
<b>F</b>	6	4X20 MM			1		
<b>G</b>	6	6X45 MM					
<b>H</b>	4	6X30 MM					
<b>I</b>	4	Ø16MM					

■ **6x40mm PRIVIJAČENJE VIJAKOV KOT NAZNAČENO SPODAJ :**  
**6x25mm Montage des Bolzens (siehe unten):**  
**BOLT INSTALLATION AS BELOW:**

	<b>VIJAK</b> Schraube Bolt
	<b>KONEKTOR</b> Verbindungsstück Connecting piece

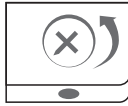
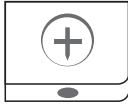
	
X	✓
VSTAVI VIJAK, KO JE SITUACIJA KONEKTORJA KOT NA SLIKI Drehen Sie das Verbindungsstück weiter wenn Sie es in der oben abgebildeten Position vorfinden <i>Rotate connecting piece if found in position illustrated above</i>	PRILAGODI SMER KONEKTORJA, ČE JE SITUACIJA KOT NA SLIKI Korrekte Ausrichtung zur Verbindung der Schrauben und Verbindungsstück <i>Correct orientation to receive bolts</i>

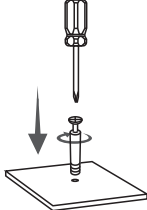
**A1.** 

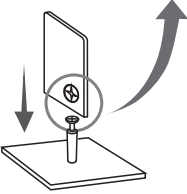
**A2.** 

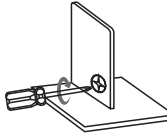
**A3.** 

■ **KORAKI SESTAVE/ Aufbauschnitte /ASSEMBLY STEPS:**

**1**

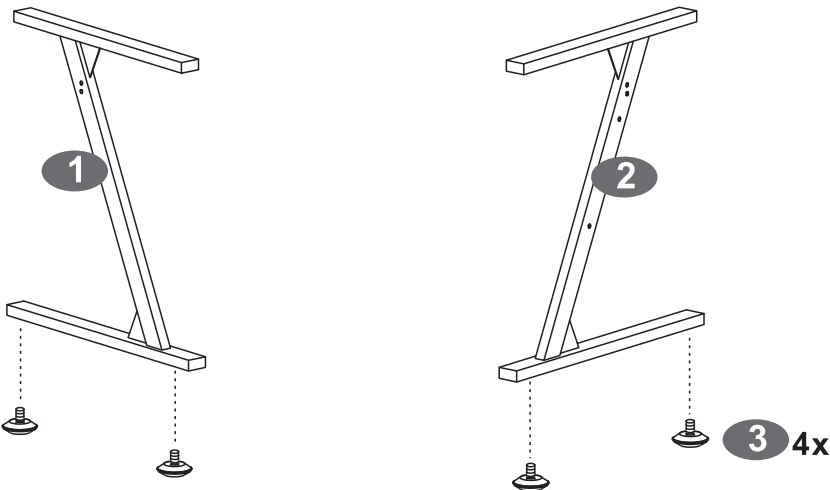

**2**

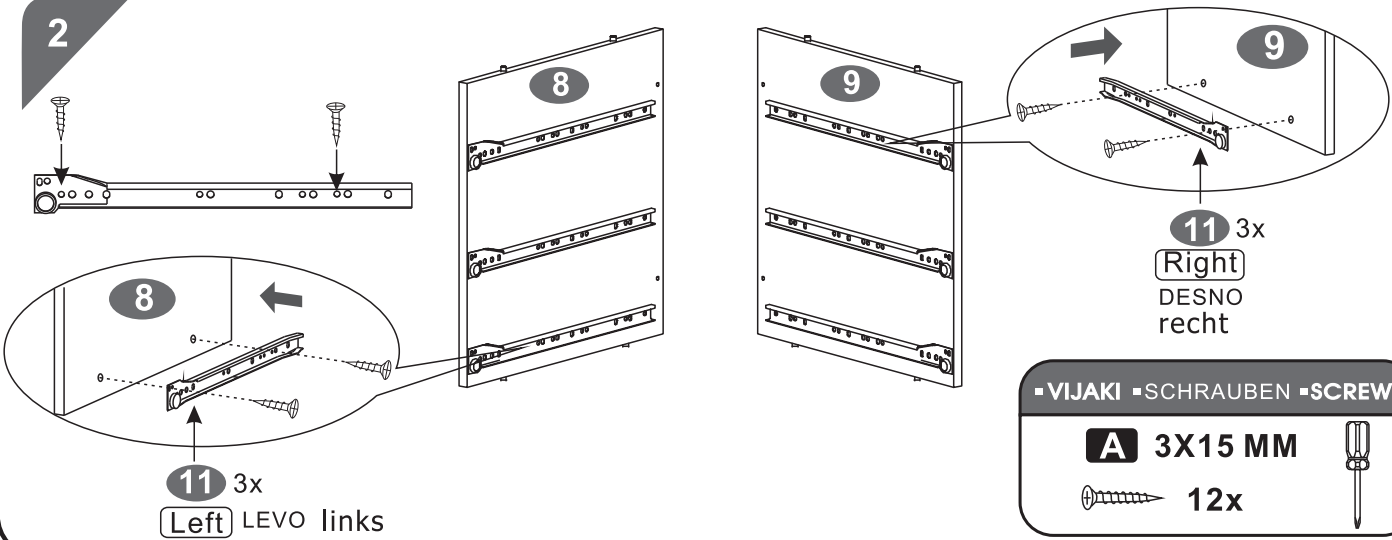

**11** 3x  
Left LEVO links

**11** 3x  
Right DESNO recht

-VIJAKI	-SCHRAUBEN	-SCREWS
<b>A</b> 3X15 MM		12x

3

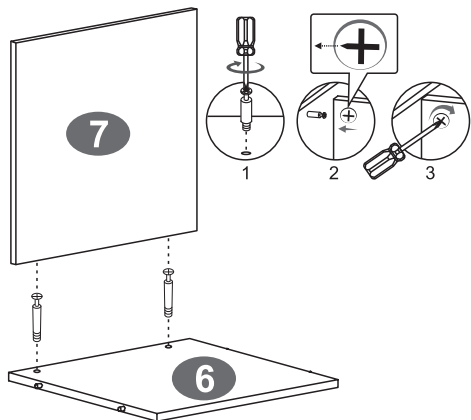

-VIJAKI -SCHRAUBEN -SCREWS

**B** 6X40 MM

2x



4

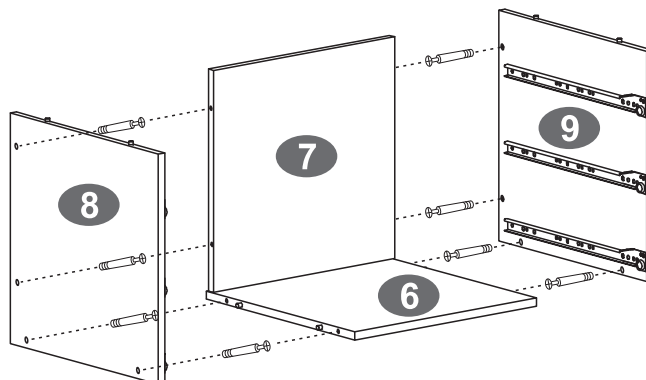

-VIJAKI -SCHRAUBEN -SCREWS

**B** 6X40 MM

8x



5

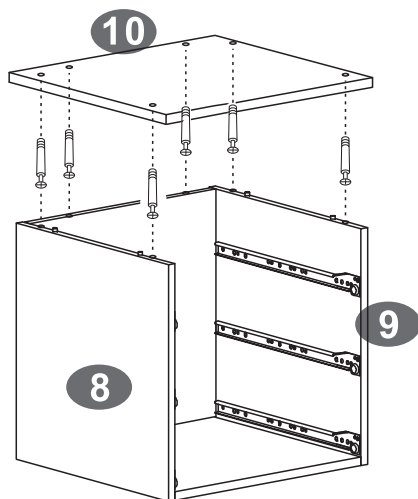

-VIJAKI -SCHRAUBEN -SCREWS

**B** 6X40 MM

6x



6

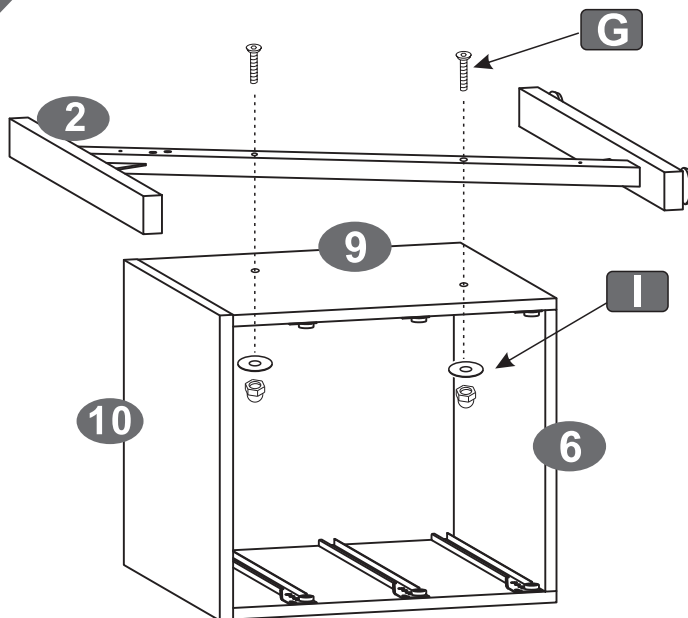

-VIJAKI -SCHRAUBEN -SCREWS

**G** 6X45 MM

2x



**I** 2x



7

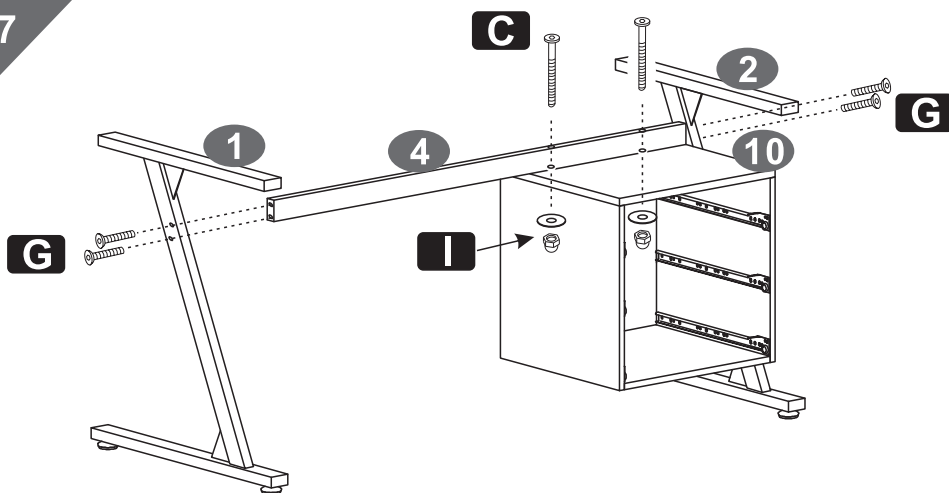

-VIJAKI -SCHRAUBEN -SCREWS

**C** 6X75 MM

2x

**G** 6X45 MM

4x

**I** 2x

-VIJAKI -SCHRAUBEN -SCREWS

**D** 6X65 MM

4x

9

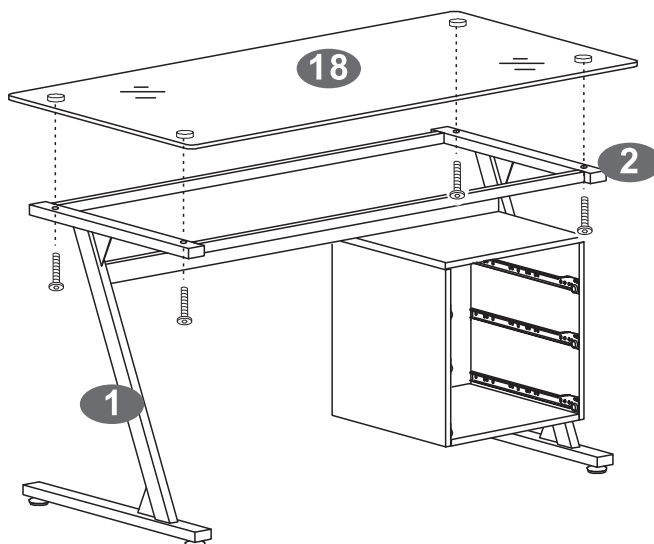

-VIJAKI -SCHRAUBEN -SCREWS

**H** 6X30 MM

4x

10

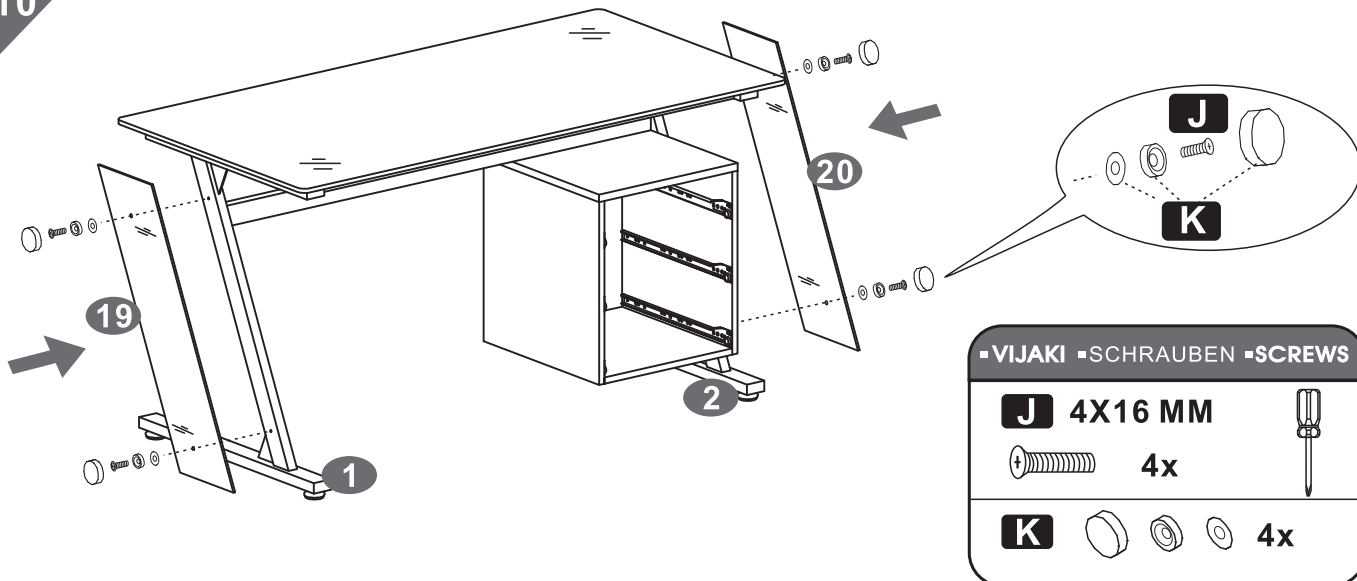

11

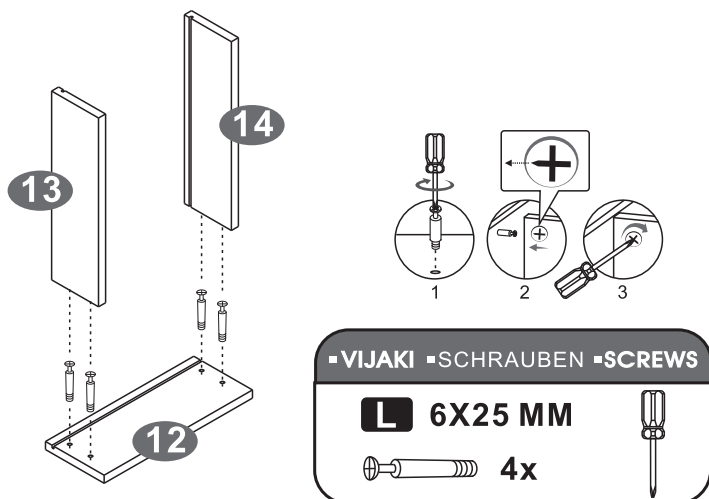

12

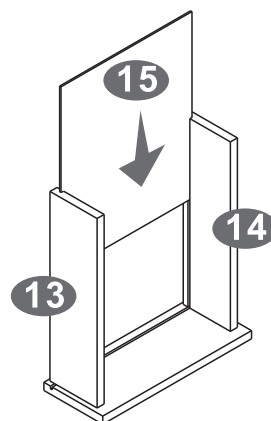

13

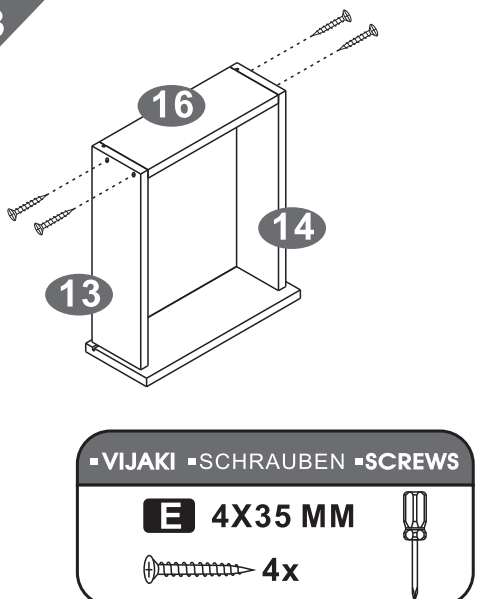

14

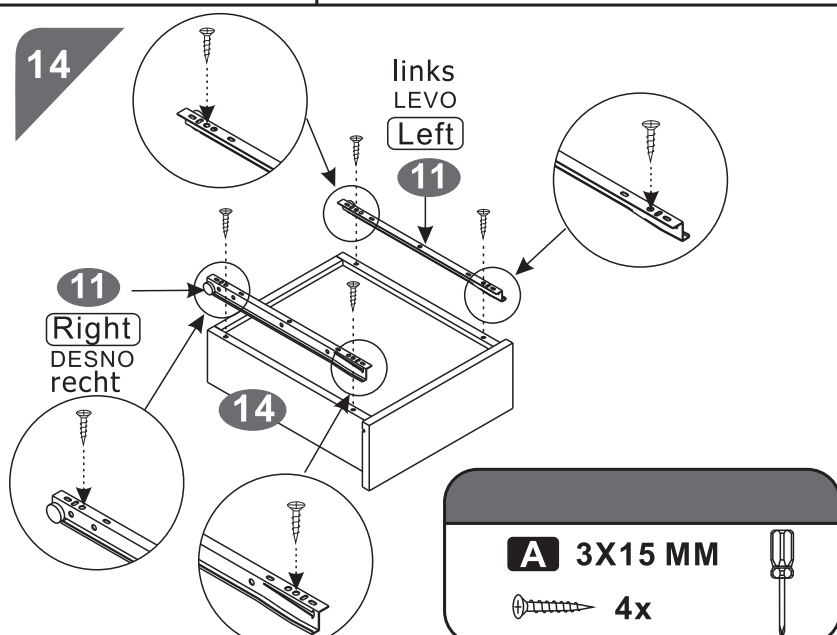

15

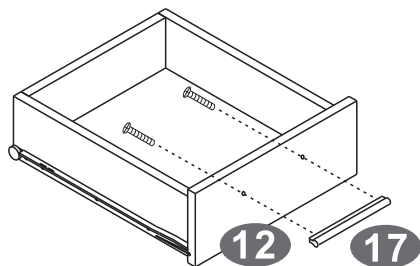

PONOVI KORAKE 11-15  
ZA SESTAVO OSTALIH  
PREDALOV

•VIJAKI •SCHRAUBEN •SCREWS

**F** 4X20 MM

 2x



16

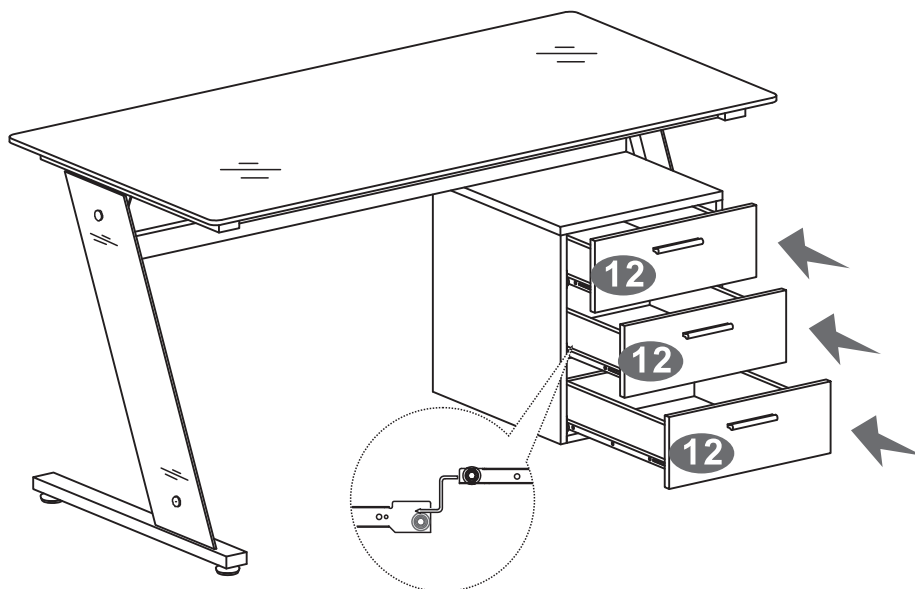

17

