

PINIO

123456789

LKZ 42416 / 75033

90

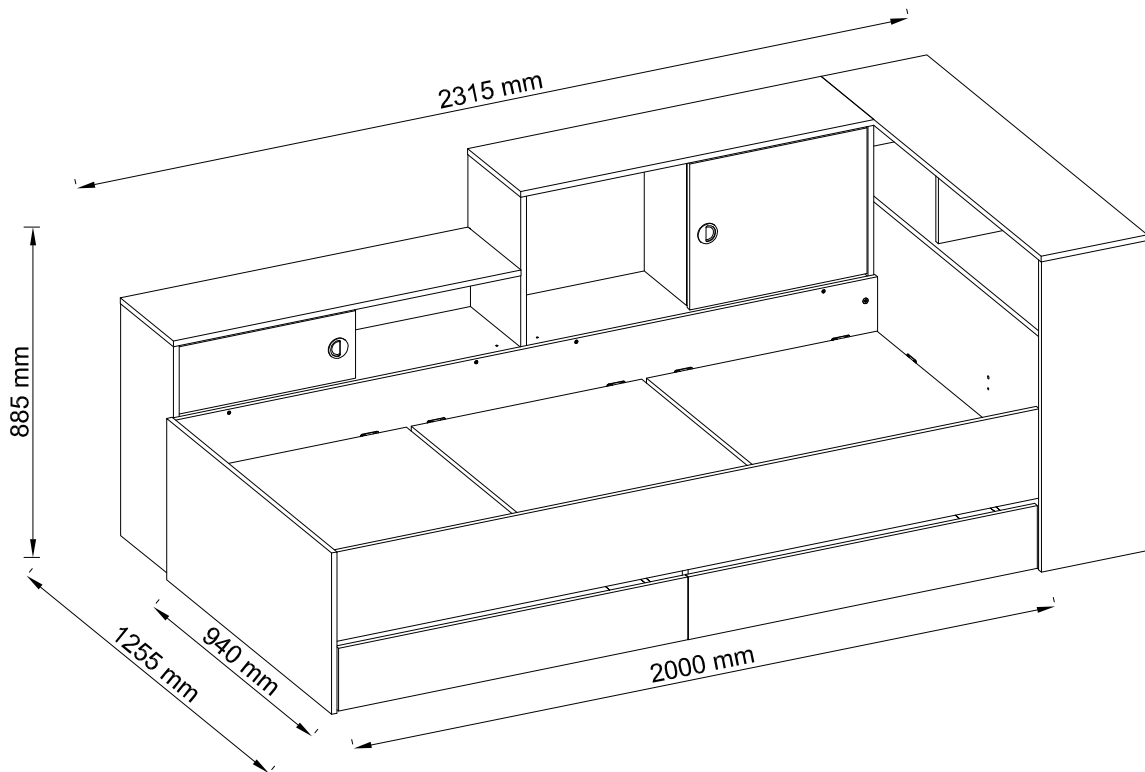

D Montageanleitung
Betten >Pinio<

FR Notice de montage
Le lit >Pinio<

NL Handleiding voor de montage
Bed >Pinio<

CZ Montážní návod
Postel >Pinio<

HU Szerelési útmutató
Ágy >Pinio<

TR Montaj talimatı
Yatak >Pinio<

ES Instrucciones de montaje
Cama >Pinio<

GB Assembly instructions
Bed >Pinio<

IT Istruzioni di montaggio
Letti >Pinio<

PL Instrukcja montażu
Łoże >Pinio<

SK Návod na montáž
Posteľ >Pinio<

RO Instrucțiuni de montaj
Pat >Pinio<

RU Инструкция по монтажу
Кровати >Pinio<

PT Instruções de montagem
Cama >Pinio<

SRB Упутства за инсталацију
Лежај на кревету >Pinio<

HR Upute za instalaciju
Krevet >Pinio<

SL Návod na montažo
Postelja >Pinio<

LT Surinkimo instrukcijos
Gulta >Pinio<

LV Montāžas instrukcija
Lova >Pinio<

EE Kokkupaneku juhised
Voodi >Pinio<

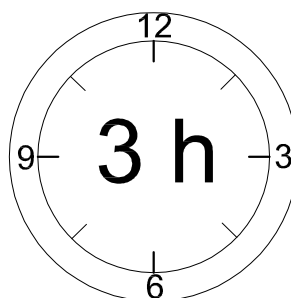
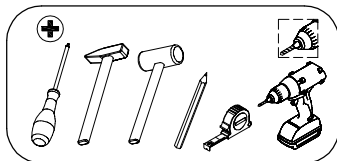
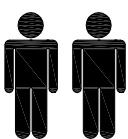

D-Ziehen Sie alle Schrauben sowie tragende Verbindungsteile nach ca. 5 Wochen nach, um ein dauerhafte Standsicherheit zu gewährleisten.

GB-After approx. 5 weeks, tighten all screws and load-bearing connecting parts to ensure permanent stability.

FR-Resserrez toutes les vis ainsi que les pièces de fixation au bout d'environ 5 semaines pour garantir une sécurité de fixation durable.

IT- Ristringere tutte le viti e giunture dopo ca. 5 settimane, al fine di garantire una durevole solidità.

NL-Draai alle schroeven en ook dragende verbindingstukken na ca. 5 weken nog eens vast, zodat een continue stabiliteit wordt gegarandeerd.

PL-Prosimy po ok. 5 tygodniach dokręcić wszystkie śruby i elementy łączeniowe. Zagwarantuje to Państwu trwałość i stabilność połączeń.

CZ- Dotáhněte všechny šrouby a nosné spojovací díly přibližně po 5 týdnech, aby se zaručila trvalá stabilita.

SK-Po cca 5 týždňoch dotiahnite skrutky, aby bola zaručená ich trvalá stabilita.

HU-Húzza utána - kb. 5 hét múlva - az összes csavart és a teherhordó összekötő-alkatrészeket abiztonság érdekében.

RO-Pentru a asigura o stabilitate de durată, strângeți după cca. 5 săptămâni toate șuruburile, precumși toate elementele portante de legătură.

TR-Tüm vida ve taşıyıcı bağlantı parçalarını kalıcı bir duruş güvenliğini sağlamak için yaklaşık 5 haftasonra tekrar sıkınız.

RU - Подкрутите все болты, а также несущие соединительные детали припл. через 5 недель для обеспечения устойчивости в течение длительного времени.

SRB - Molim vas posle akroska. 5 nedelja zategnite sve šrafove i pričvršćivače. To ће вам гарантовати трајност и стабилност веза.

HR - Molim vas, nakon cca. 5 tjedana zategnite sve vijke i pričvršćivače. To će vam jamčiti trajnost i stabilnost priključaka.

SL - Pýtame sa po cca. 5 týždňov utiahnite všetky skrutky a upevňovacie prvky. To zaručuje trvanlivosť a stabilitu spojov.

LT - Mes prašome po maždaug. 5 savaites priveržkite visus varžtus ir tvirtinimo detales. Taip užtikrinamas jungčių patvarumas ir stabilumas.

LV - Mēs lūdzam pēc apm. 5 nedēļas, pievelciet visas skrūves un stiprinājumus. Tas garantē savienojumu izturību un stabilitāti.

EE - Küsime pärast ca. 5 nädalat, pingutage kõik kruvisid ja kinnitused. See tagab ühenduste vastupidavuse ja stabiilsuse.

ES-Apriete todos los tornillos y elementos de conexión después de aproximadamente 5 semanas. Esto le garantizará la durabilidad y estabilidad de sus conexiones.

PT-Por favor, aperte todos os parafusos e elementos de ligação após aproximadamente 5 semanas. Isto garantirá a durabilidade e a estabilidade das suas ligações.

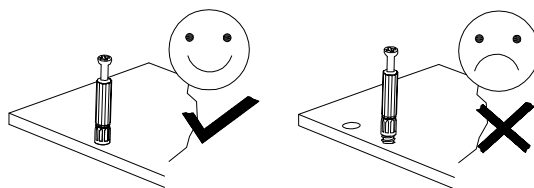

D Bitte nur mit einem Staubtuch oder leicht feuchtem Lappen reinigen. Keine scheuernden Putzmittel verwenden.

GB Please only clean with a duster or a damp cloth. Do not use any abrasive cleaners.

FR Veuillez nettoyer uniquement avec un chiffon à poussière ou un chiffon légèrement humide. Ne pas utiliser de détergent abrasif.

IT Si raccomanda di pulire solo con un panno per la polvere o uno strofinaccio umido. Non utilizzare detersivi abrasivi.

NL Reinig alleen met een stofdoek of een lichtjes vochtige doek. Gebruik geen schurende poetsmid-delen.

PL Czyszczenie należy wykonać wyłącznie za pomocą ściereczki lub lekko nawilżonego ręcznika. Nie stosować środków czyszczących do szorowania.

CZ Čistěte prosím jen prachovkou nebo lehce navlhčeným hadrem. Nepoužívejte drhnutí čistící prostředky.

SK Na čistenie používajte len prachovku alebo zľahka navlhčenú utierku. Nepoužívajte žiadne drhúce čistiace prostriedky.

HU Kérjük, csak portórlő kendővel vagy enyhén nedves ronggyal tisztítsa. Ne használjon dörzsátásztisztítószer.

RO Vă rugăm să utilizați la curățare exclusiv o cârpă de șters praful sau o cârpă ușor umezită. Nu utilizați substanțe de curățat abrazive.

TR Lütfen sadece bir toz bezıyla veya hafif nemli yumuşak bir bezle siliniz. Aşındırıcı temizlik malze-meleri kullanmayınız.

RU Для чистки используйте, пожалуйста, тряпку для пыли или слегка влажную ветошь. Не использовать абразивные чистящие средства.

SBR Чишћење треба обавити само крпом или благо влажним пешкиром. Немојте користити средство за чишћење рибања.

HR Čišćenje treba obaviti samo krpom ili благо navlaženim ručnikom. Ne koristite sredstva za čišćenje ribanja.

SL Čistenie by sa malo vykonávať len handričkou alebo ľahko navlhčeným uterákom. Nepoužívajte čistiace prostriedky na drhnutie.

LT Valyti galima tik šluoste arba lengvai sudrėkintu rankšluosčiu. Nenaudokite šveičiamųjų valiklių.

LV Tīršana jāveic tikai ar drānu vai viegli samitrinātu dvieli. Neizmantojiet tīršanas līdzekļus.



EE Puhastada tohib ainult lapiga või kergelt niisutatud rätikuga. Ärge kasutage puhastusvahendeid.

ES La limpieza debe realizarse únicamente con un paño o una toalla ligeramente humedecida. No utilice productos de limpieza abrasivos.

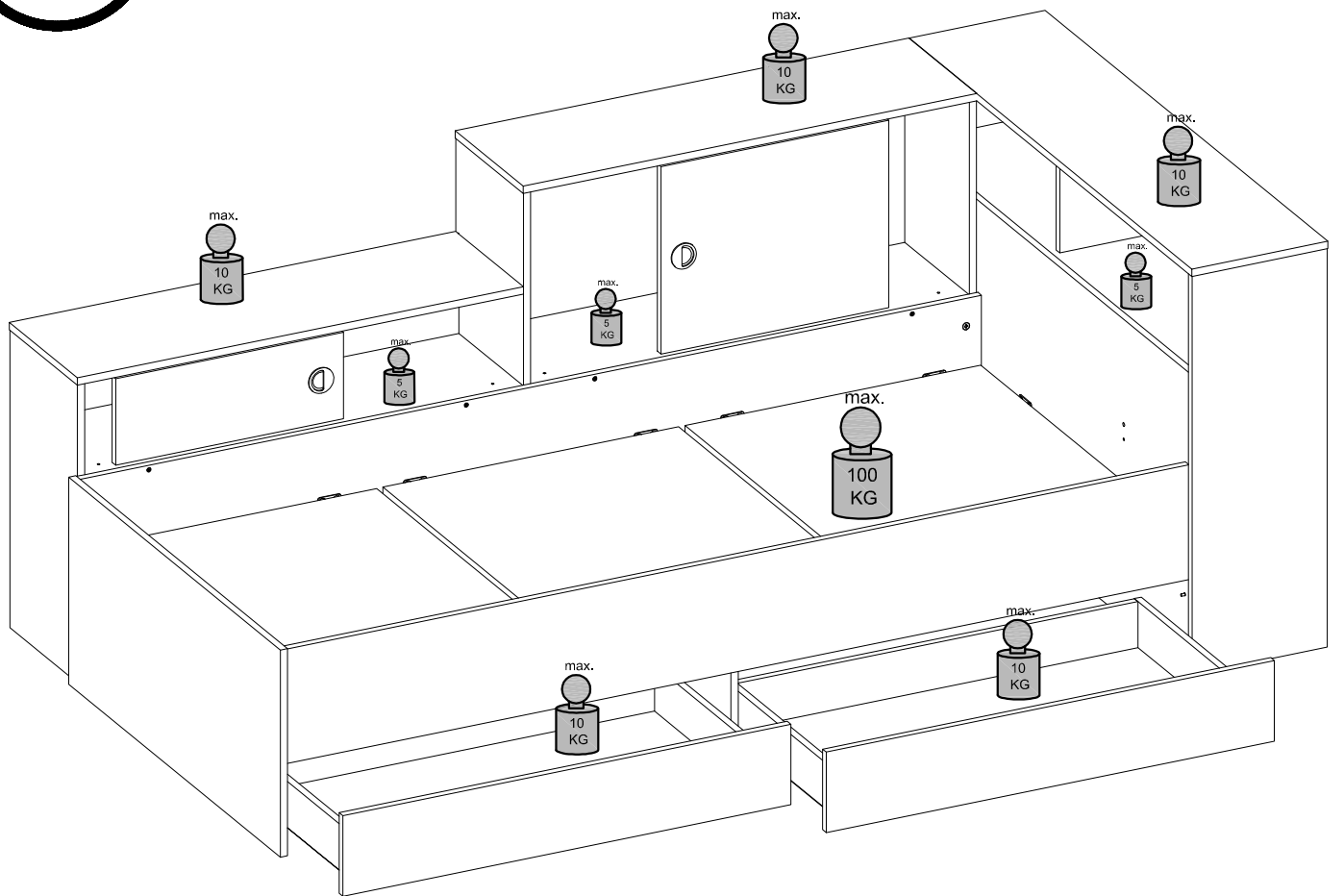
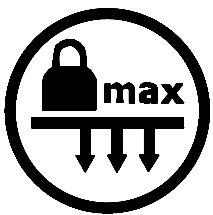
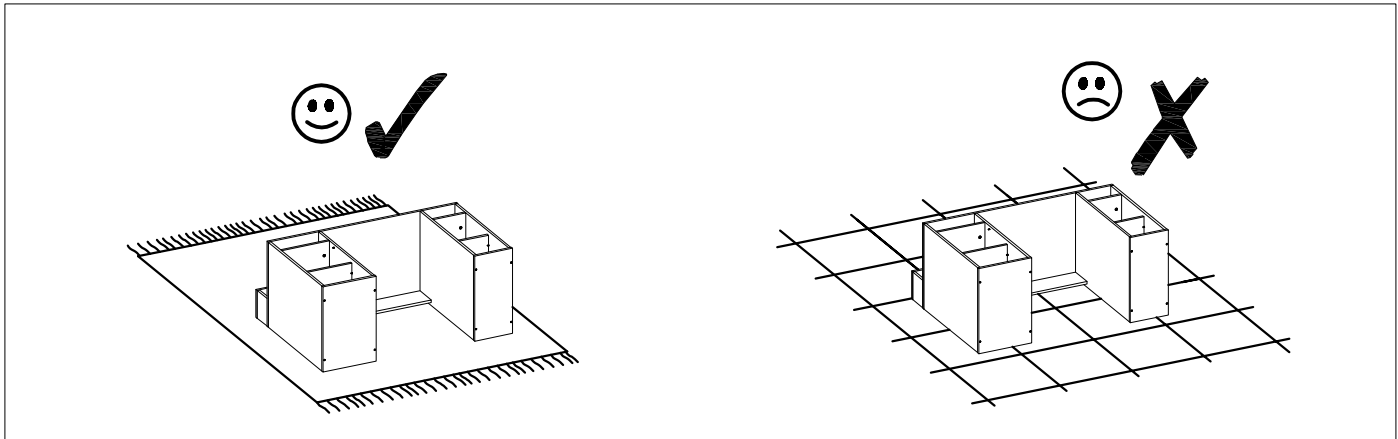
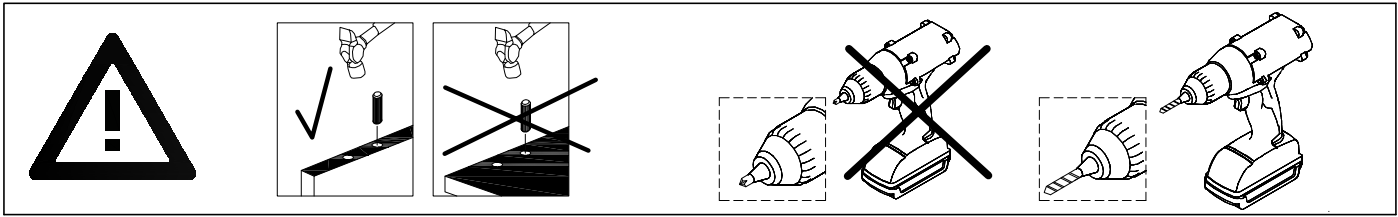
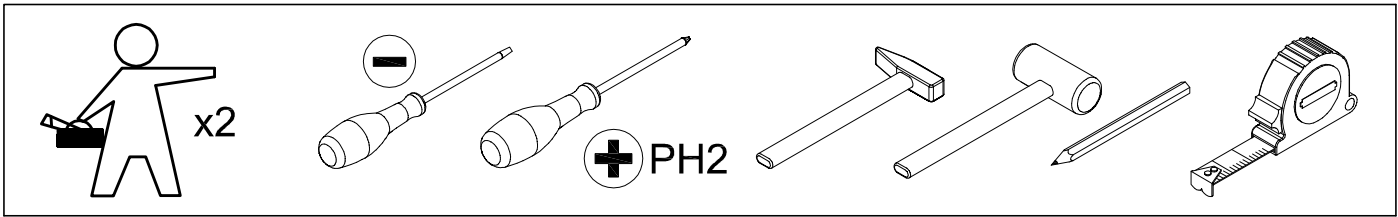
PT A limpeza deve ser feita apenas com um pano ou toalha ligeiramente húmida.

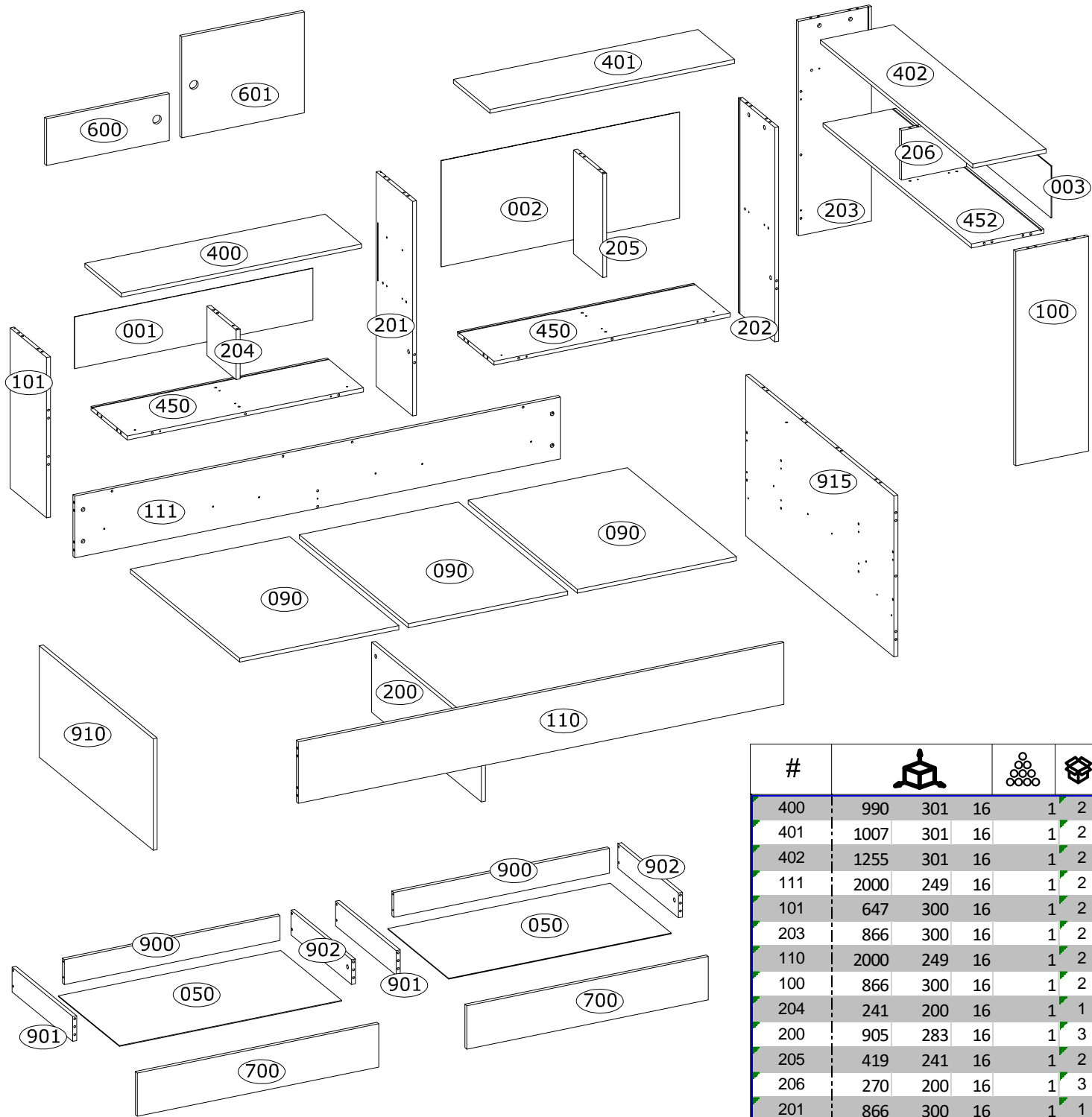



#					
400	990	301	16	1	2
401	1007	301	16	1	2
402	1255	301	16	1	2
111	2000	249	16	1	2
101	647	300	16	1	2
203	866	300	16	1	2
110	2000	249	16	1	2
100	866	300	16	1	2
204	241	200	16	1	1
200	905	283	16	1	3
205	419	241	16	1	2
206	270	200	16	1	3
201	866	300	16	1	1
202	866	300	16	1	1
450	973	300	16	2	2/3
452	1221	299	16	1	3
910	939	450	16	1	3
915	1221	650	16	1	3
700	994	175	16	2	3
901	500	100	16	2	2
902	500	100	16	2	2/3
050	916	503	3	2	3
900	888	100	16	2	1
601	505	407	16	1	1
600	505	188	16	1	3
090	899	656	16	3	1
002	982	428	3	1	3
001	982	209	3	1	3
003	1230	209	3	1	2

Service · Assistenza · Dienstverlening · Serwis Servis · Szerviz · Сервисная служба · Сервис · Serwis · Servis

Name · Nom · Nome · Naam · Nazwa · Jméno · Názov · Név · Denumire · Isim · Название	Pinio	
Typ · Type · Тiп · Tipus · Тiро · Тип	90	

A Ø8x30 mm x68 3989	B Ø8x50 mm x2 3991	C Ø6,5x36,5 mm x54 4066	D Ø6,5x36,5 mm x4 266394	E Ø15x12 mm x58 3996
F Ø15 mm x28 136236	G Ø6,5 mm x4 142727	H 18x18x14 mm x2 243136	J Ø4,0x16 mm x100 3923	K Ø3,0x25 mm x52 3887
S 15x14x11 mm x25 4044	M Ø6,4x50 mm x12 3884	N 4mm x1 3984	P x16 90907	R Ø5x16 mm x2 4019
X Ø 15 mm x8 3318	T 50x22x22 mm x16 121897	U x4 IN01007	W x4 IN01006	V Ø40 mm x2 247431
Z L-972 mm x4 253721	A1 43X21X21 mm x1 66532	B1 Ø3,0x13 mm x16 3912		

PINIO 90 L

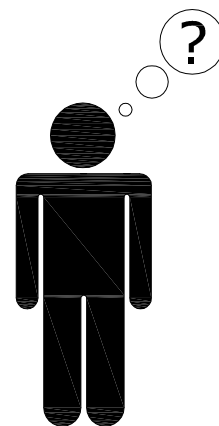
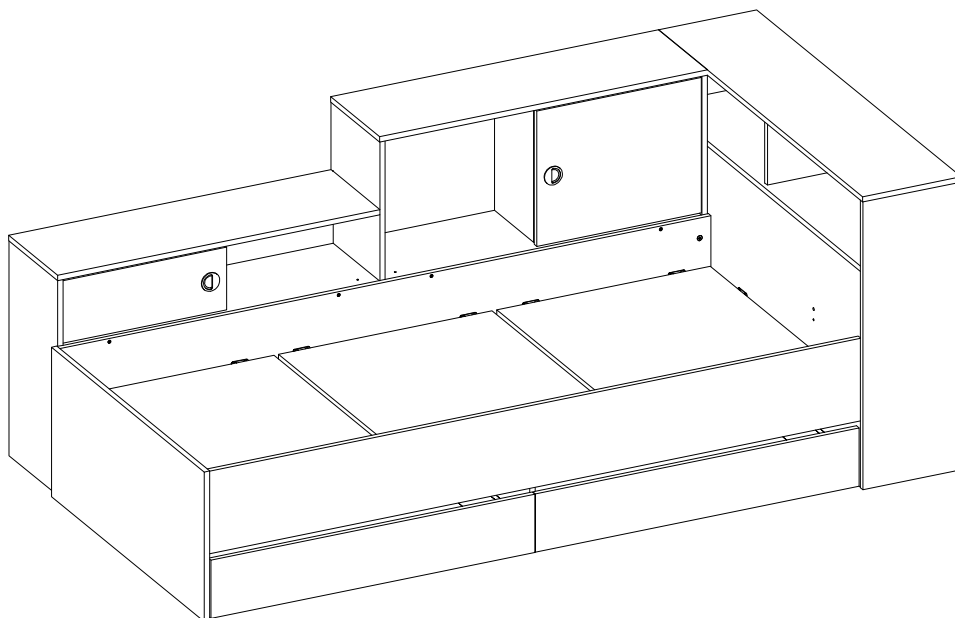

PINIO 90 R

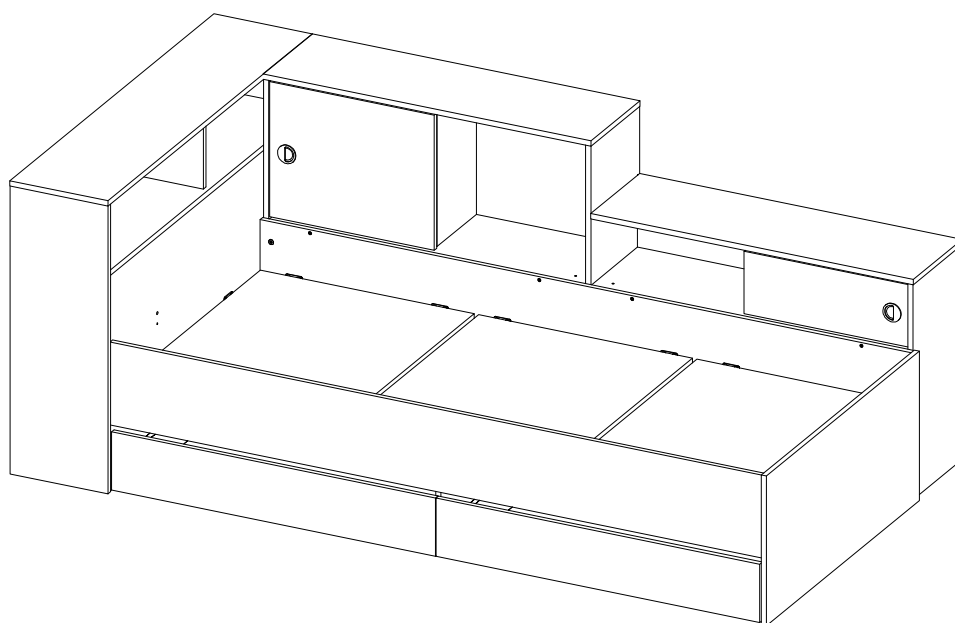

1

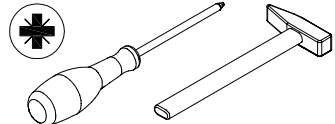
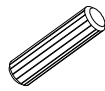
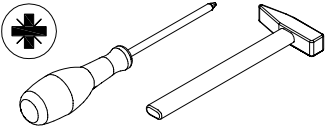
A	Ø8x30 mm	C	Ø6,5x36,5 mm	
	x4 3989		x1 4066	

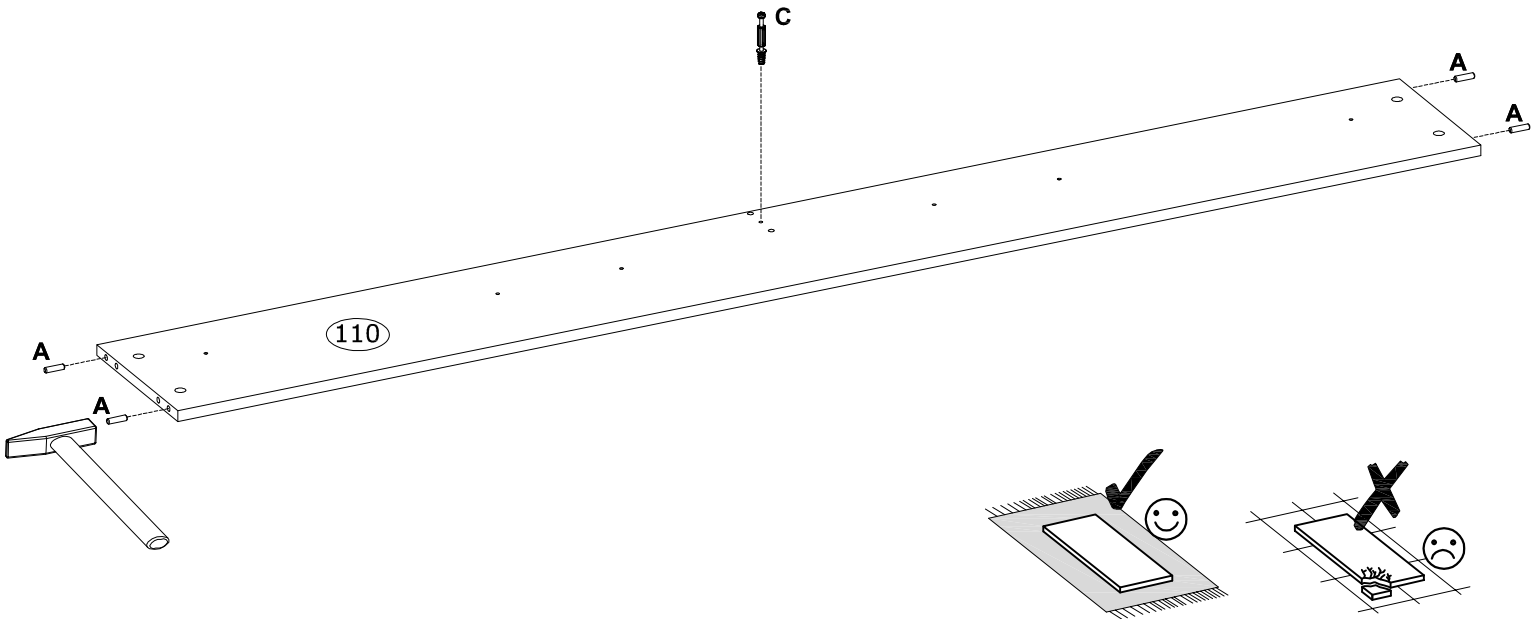

2

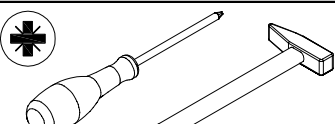
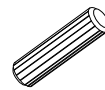
A	Ø8x30 mm	C	Ø6,5x36,5 mm	
	x4 3989		x3 4066	

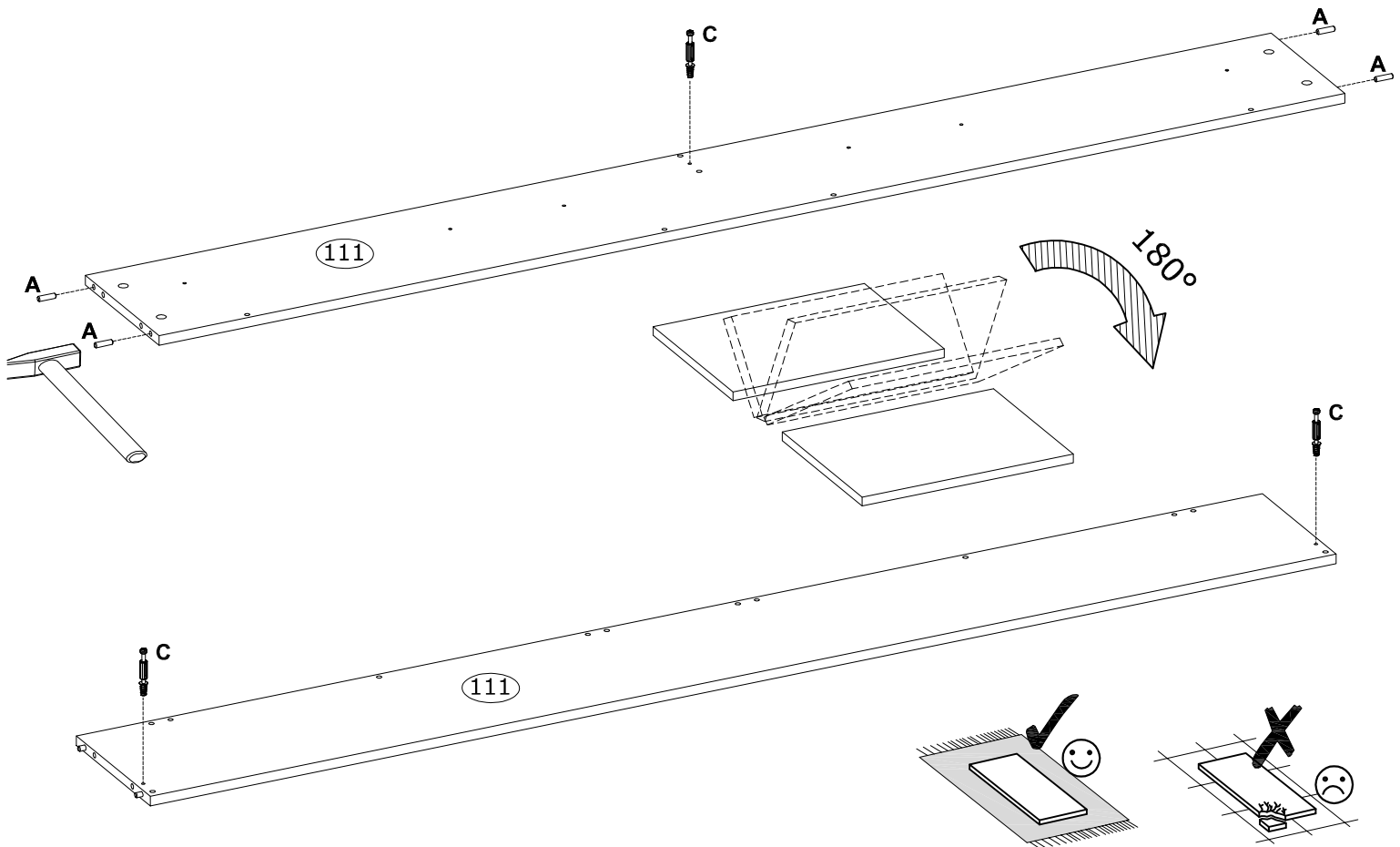

3

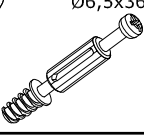
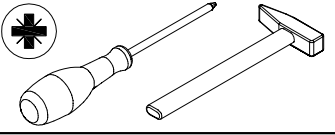
P  x2 90907	C Ø6,5x36,5 mm  x4 4066	
---	--	--

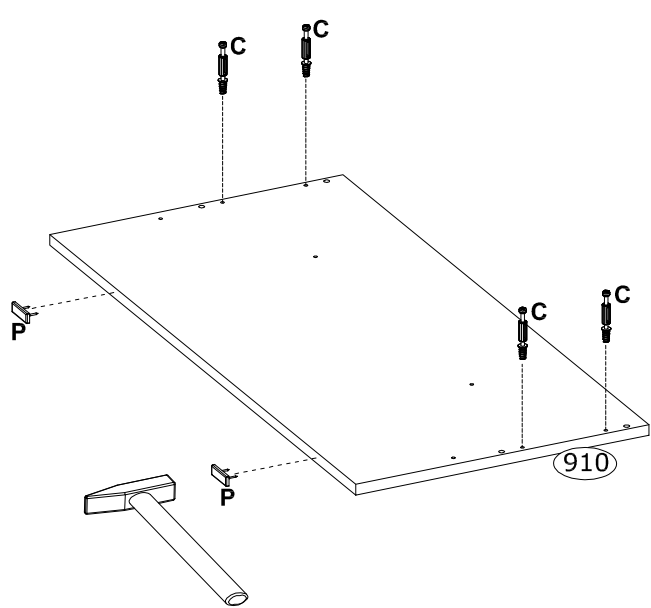

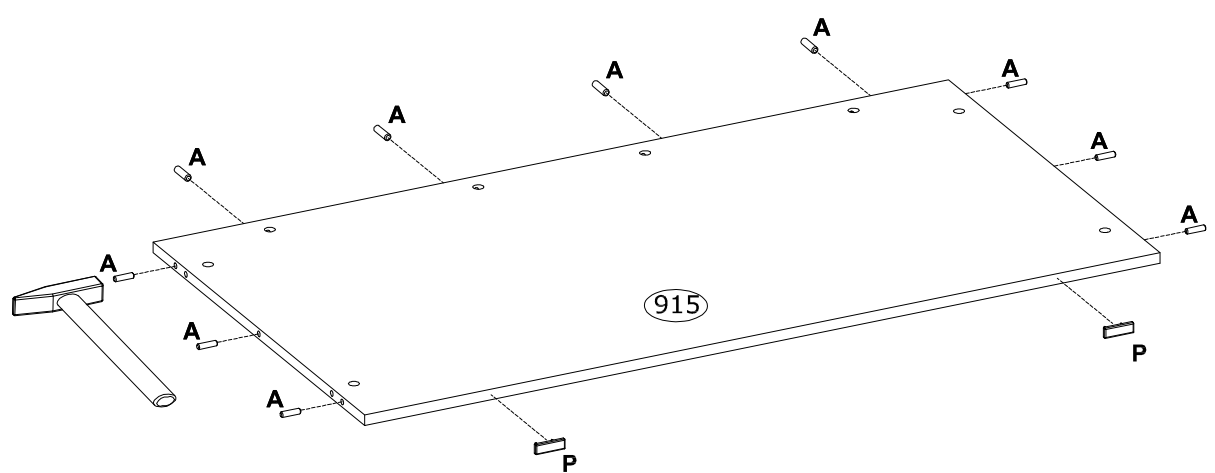

4

A Ø8x30 mm  x10 3989	P  x2 90907	
--	--	--

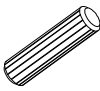

5

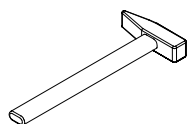
<p>A</p>  <p>Ø8x30 mm x4 3989</p>	<p>P</p>  <p>x2 90907</p>	
--	--	--

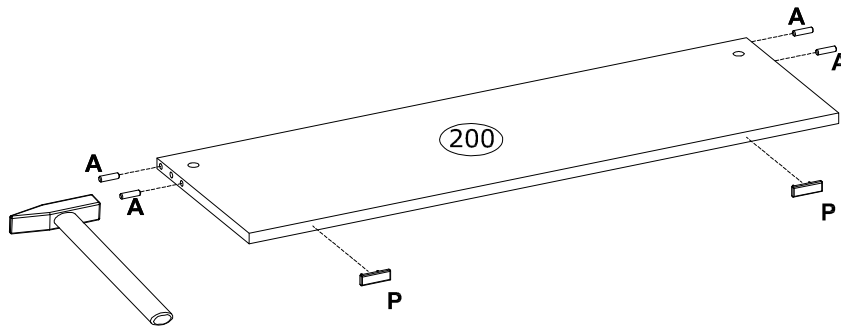

6

<p>E</p>  <p>Ø15x12 mm x2 3996</p>	
--	---

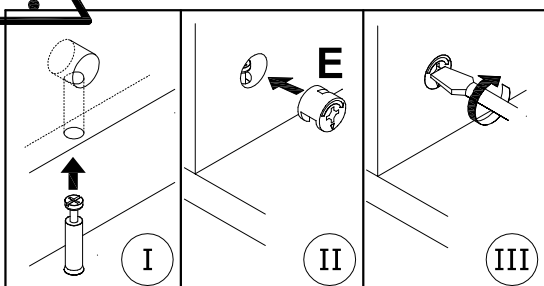
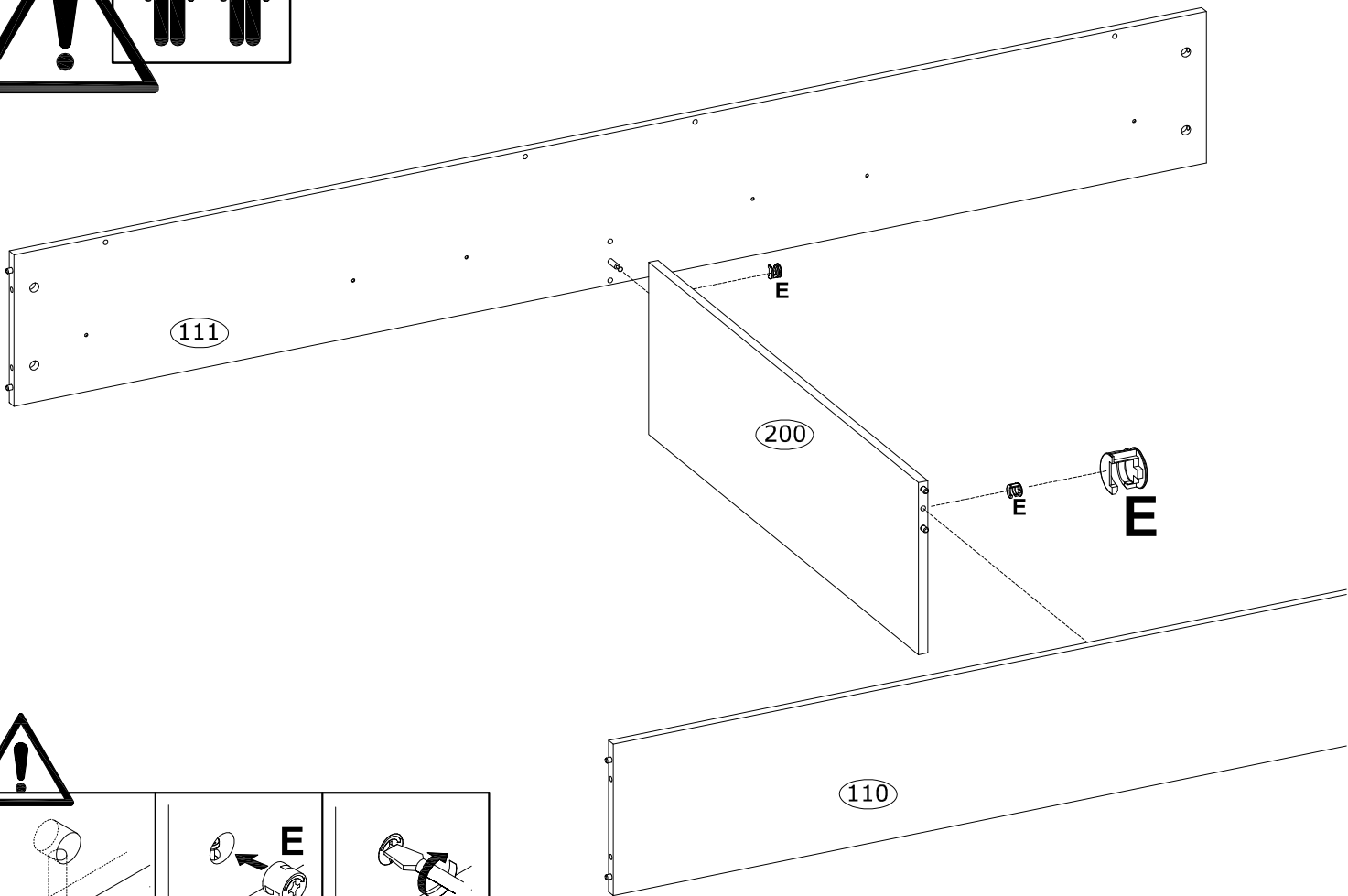
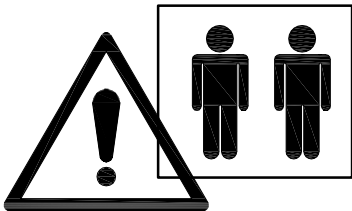

7

E
Ø15x12 mm
x4
3996

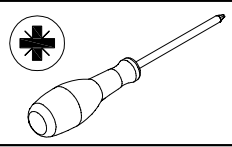
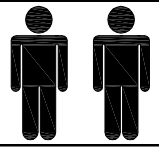

PINIO 90L

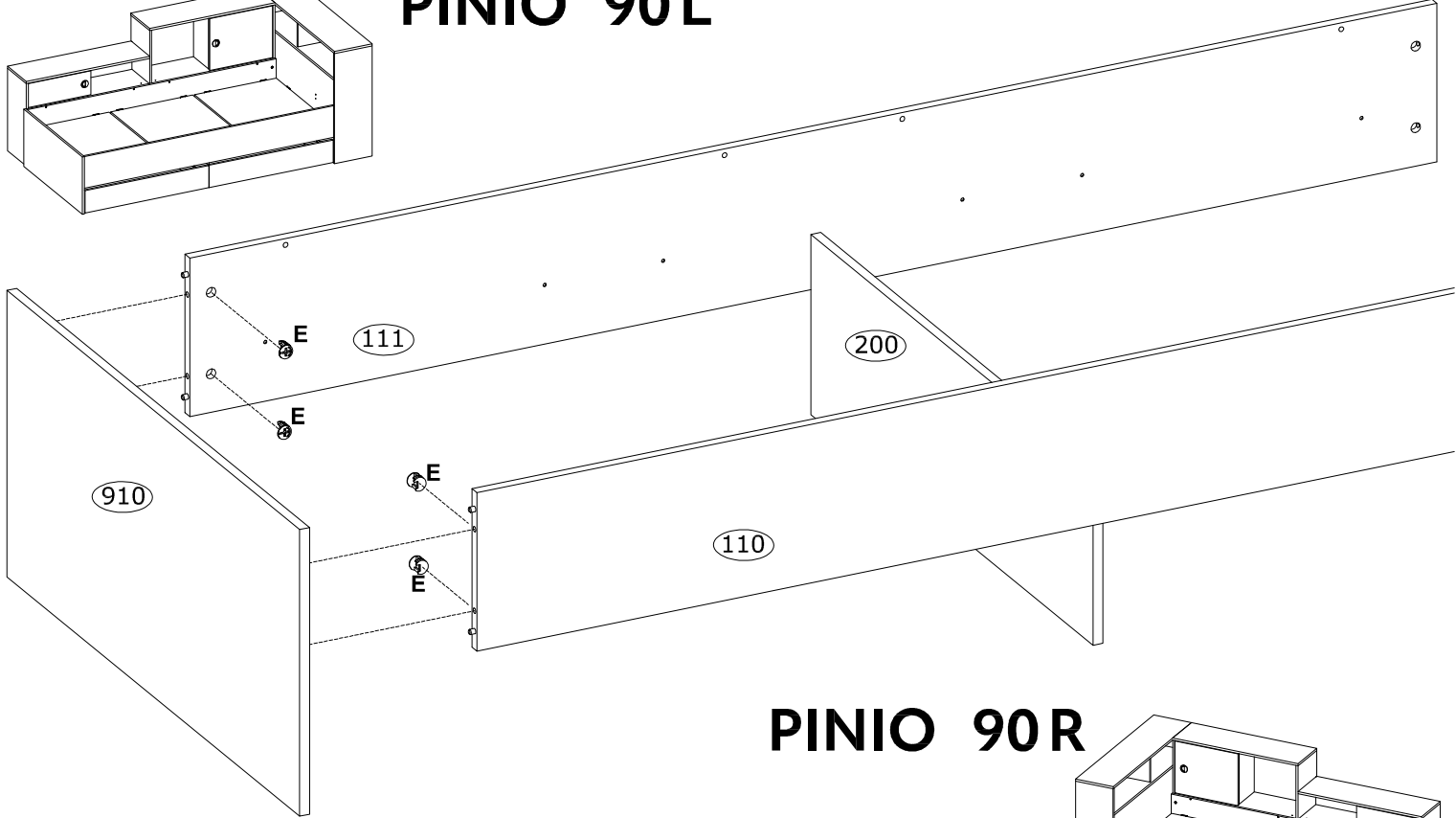
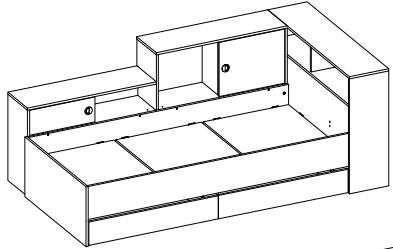

PINIO 90R

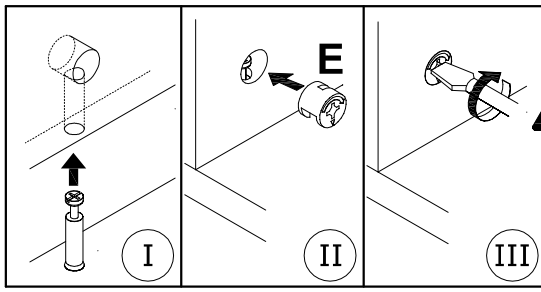
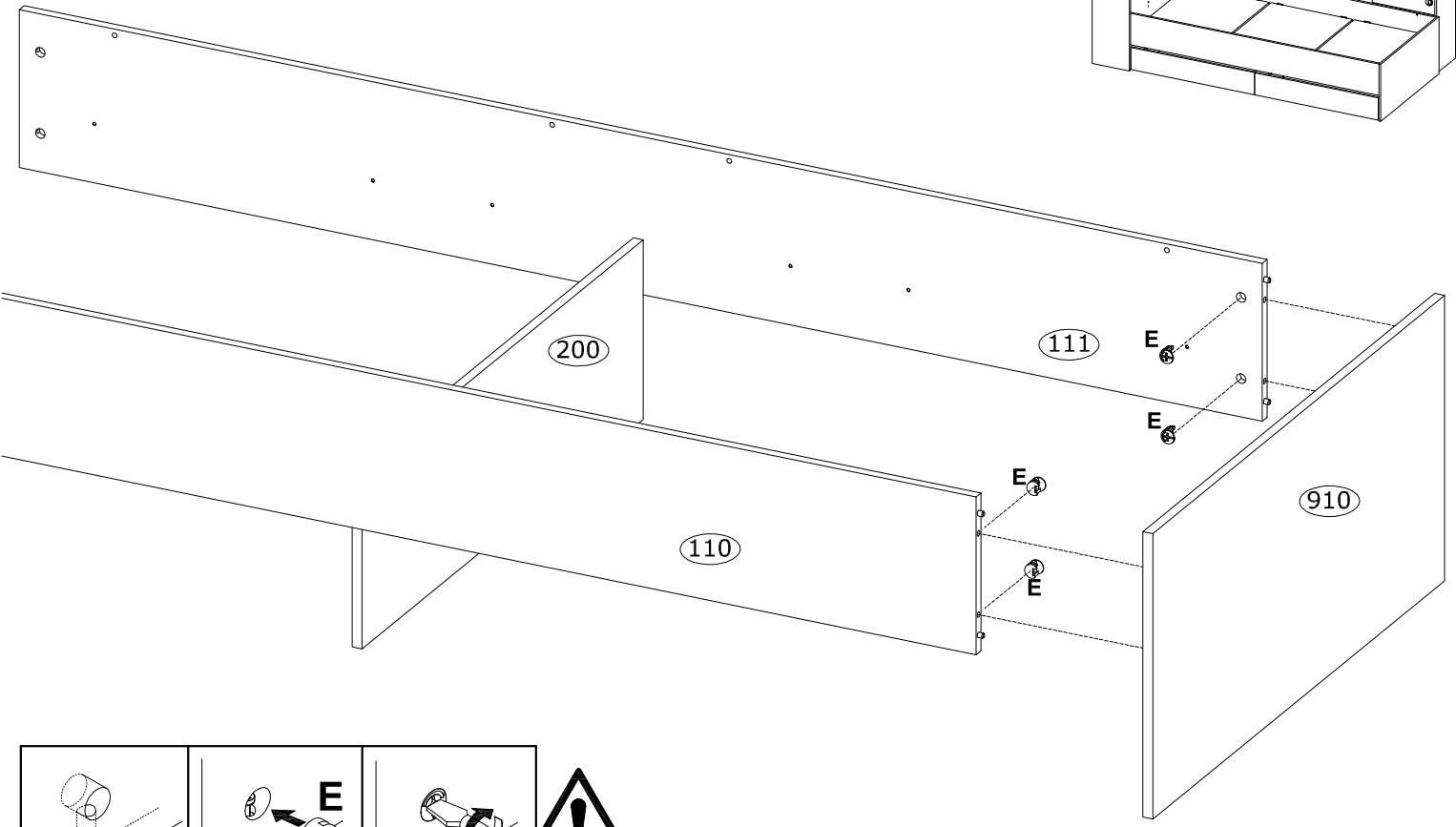
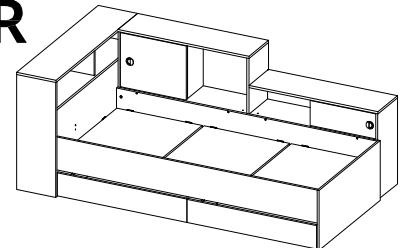

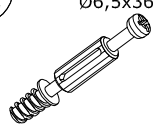
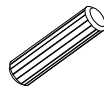
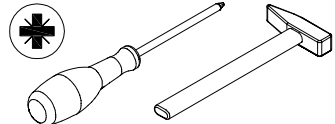

8

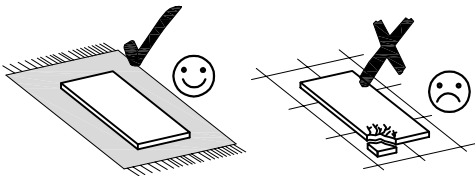
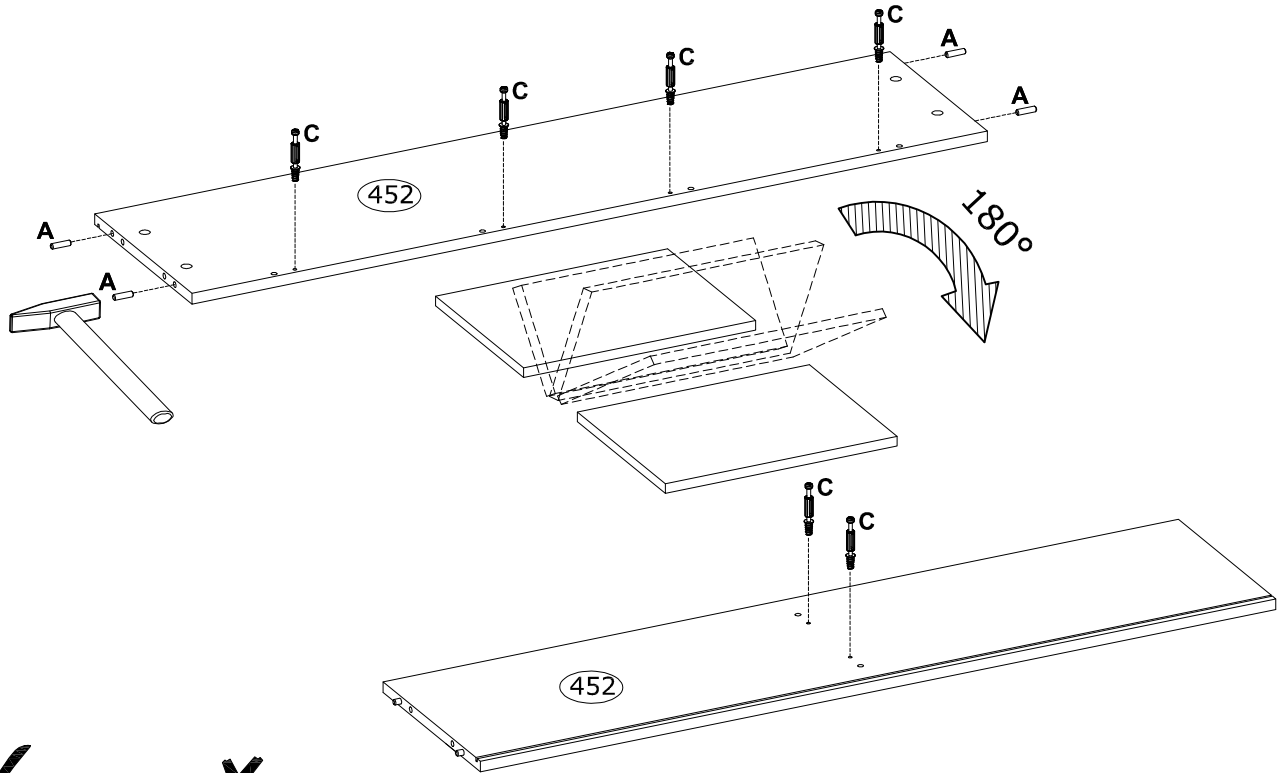
C Ø6,5x36,5 mm  x6 4066	A Ø8x30 mm  x4 3989	
--	--	--



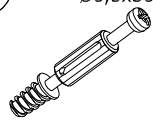
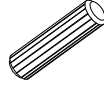

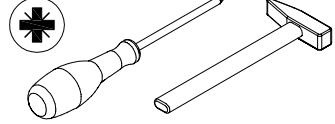
9

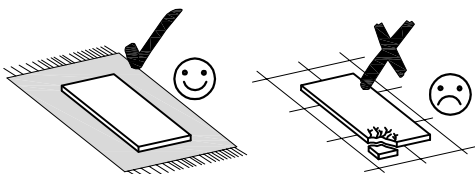
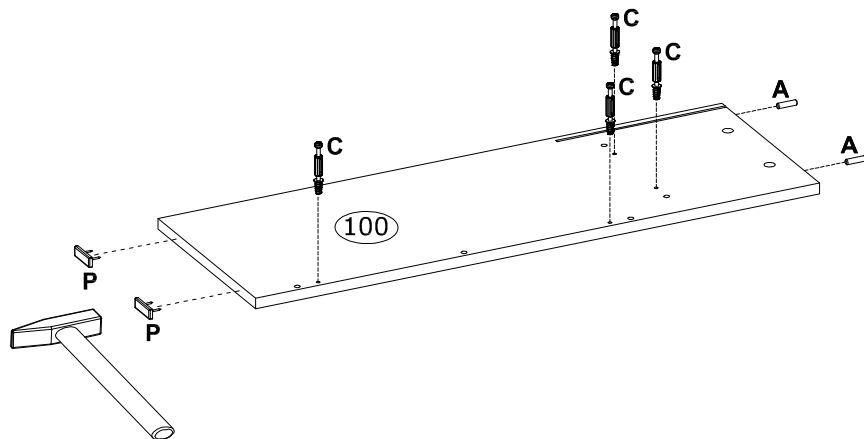
C Ø6,5x36,5 mm  x4 4066	A Ø8x30 mm  x2 3989	P  x2 90907	
---	---	--	---

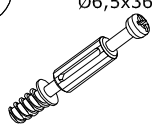
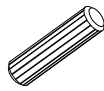

10

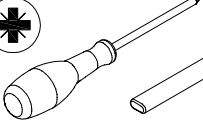
C Ø6,5x36,5 mm  x4 4066	A Ø8x30 mm  x2 3989	P  x2 90907	 
--	--	---	--

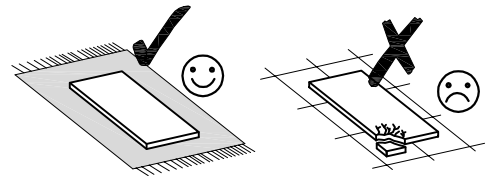
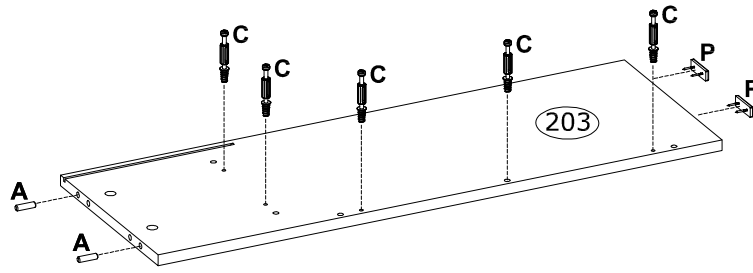

11

E Ø15x12 mm  x4 3996		 
---	--	--

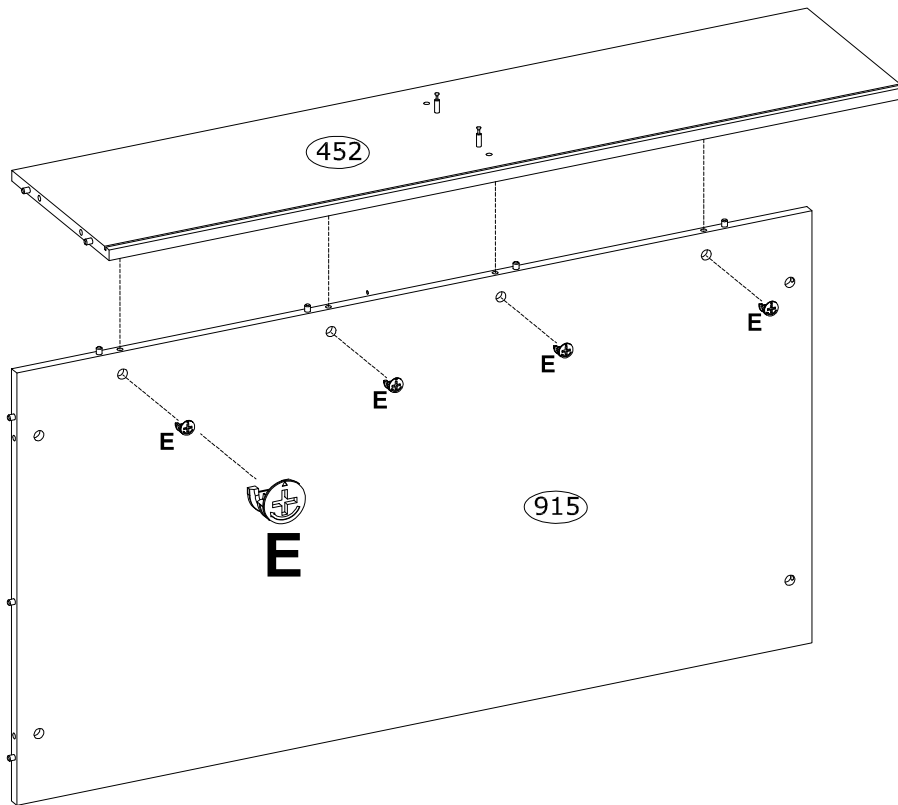

12

E
Ø15x12 mm
x8
3996

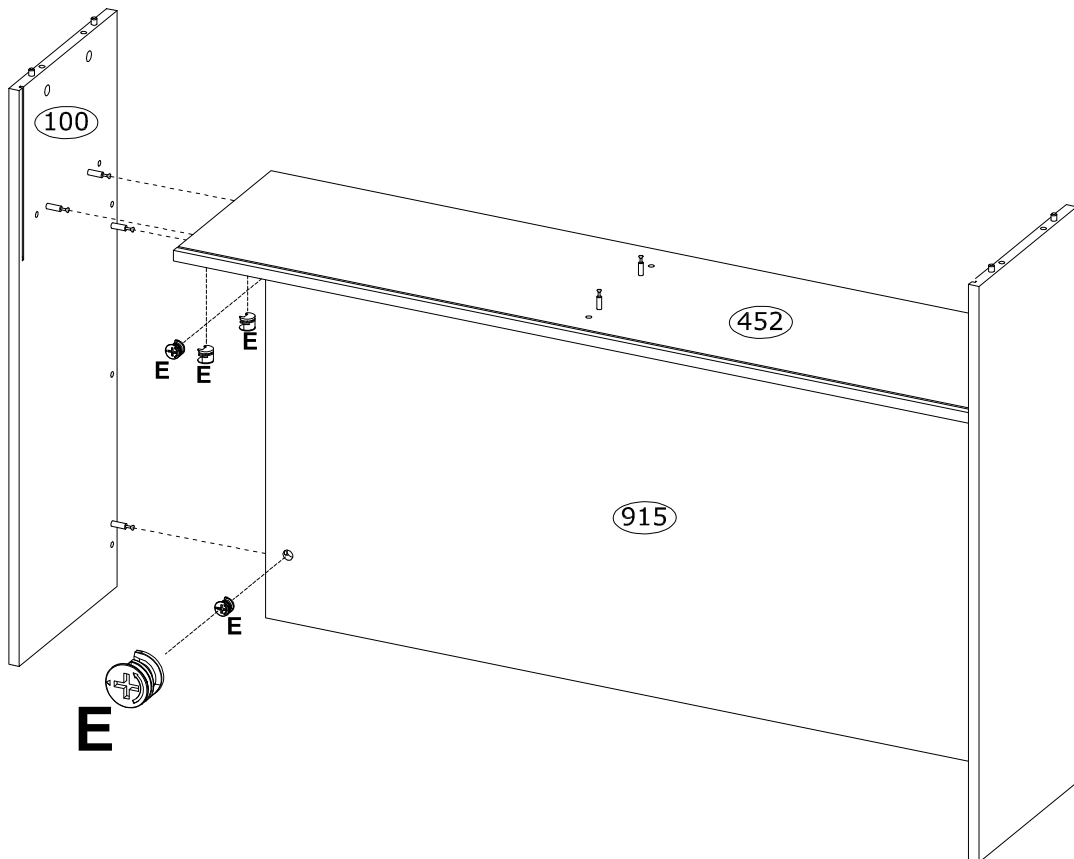
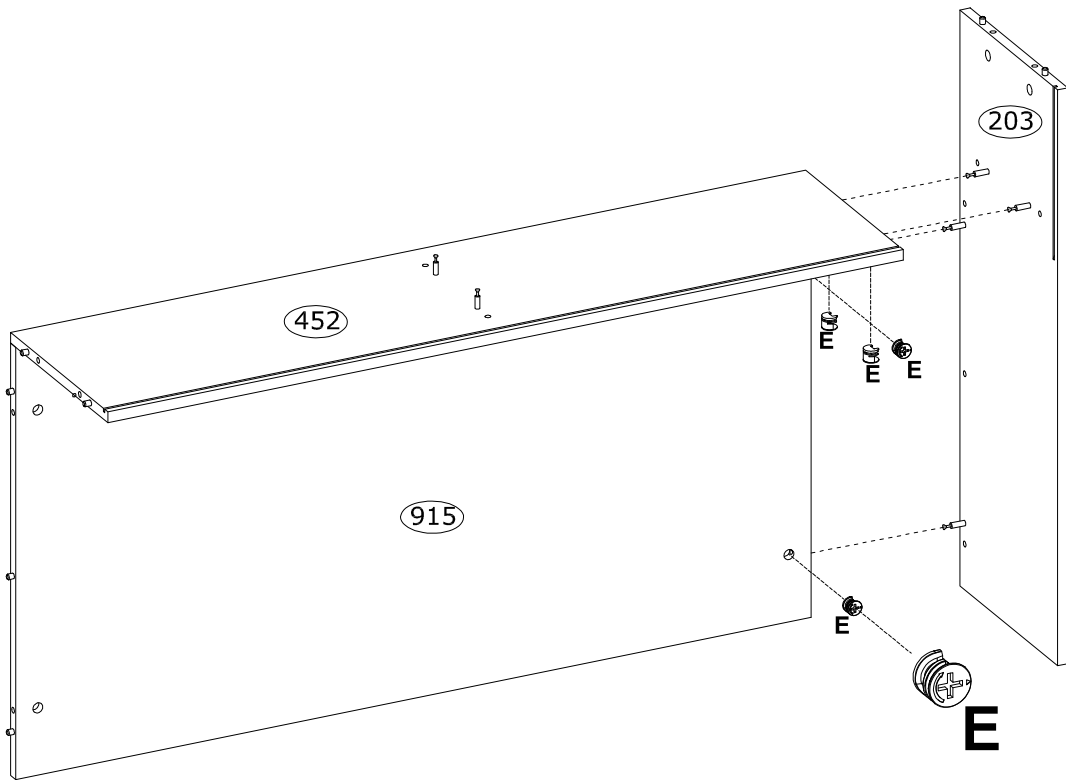
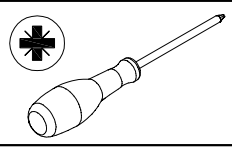
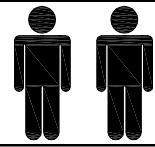

13

A Ø8x30 mm
x4
3989

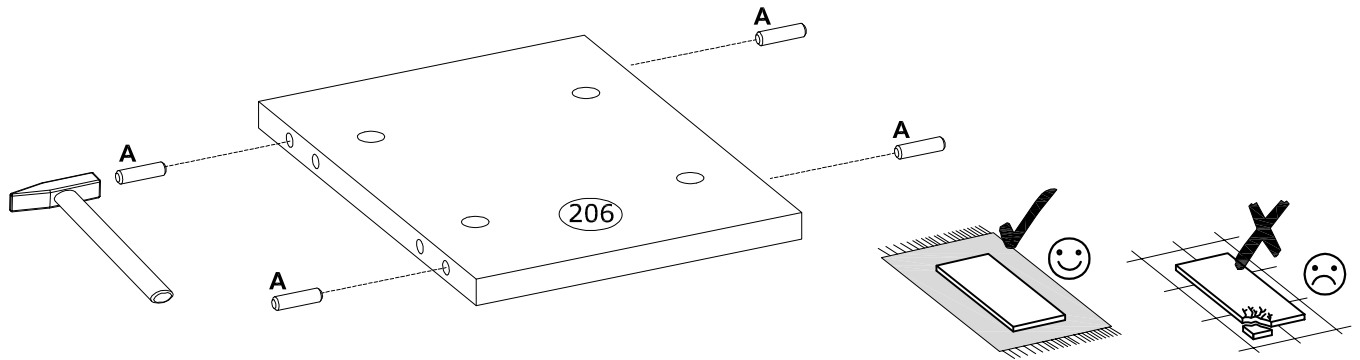
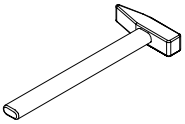

14

C Ø6,5x36,5 mm
x6
4066

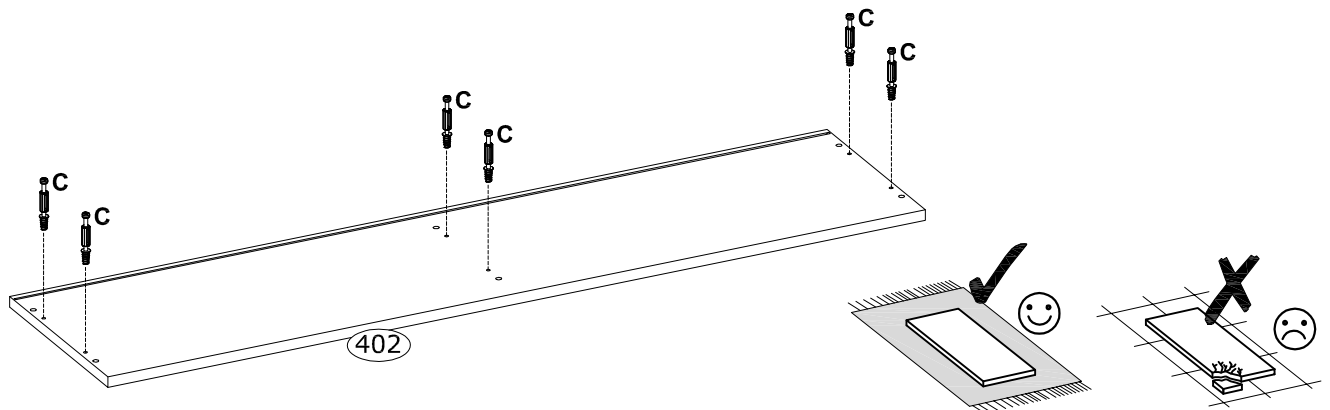

15

E Ø15x12 mm
x2
3996

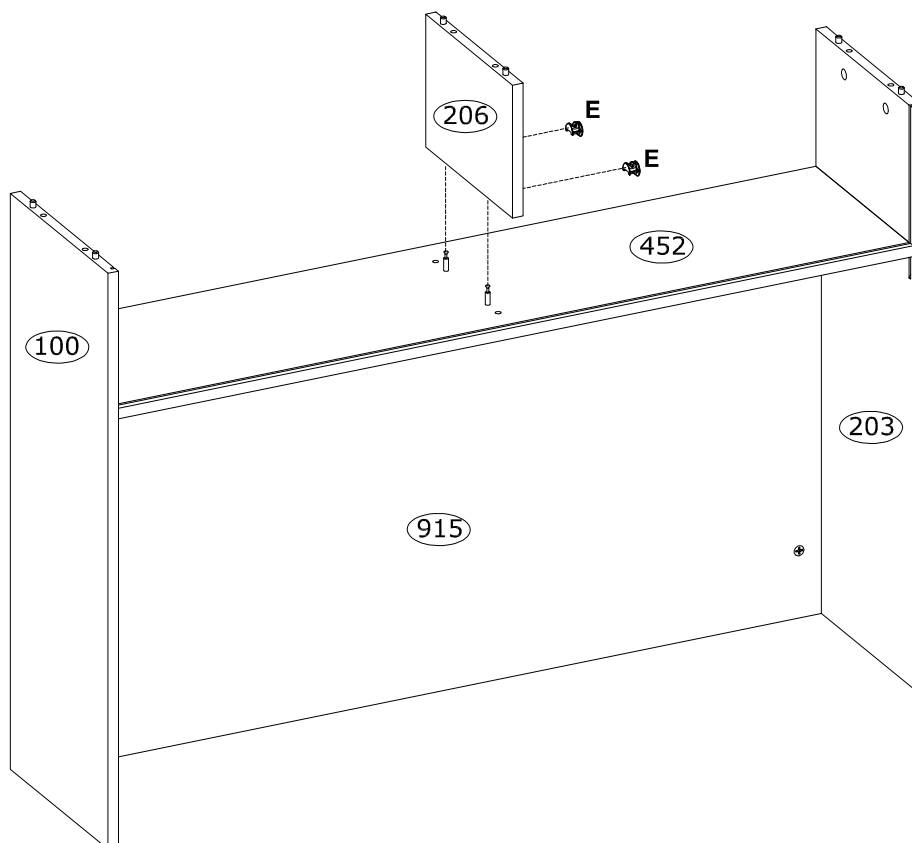
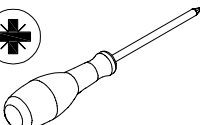

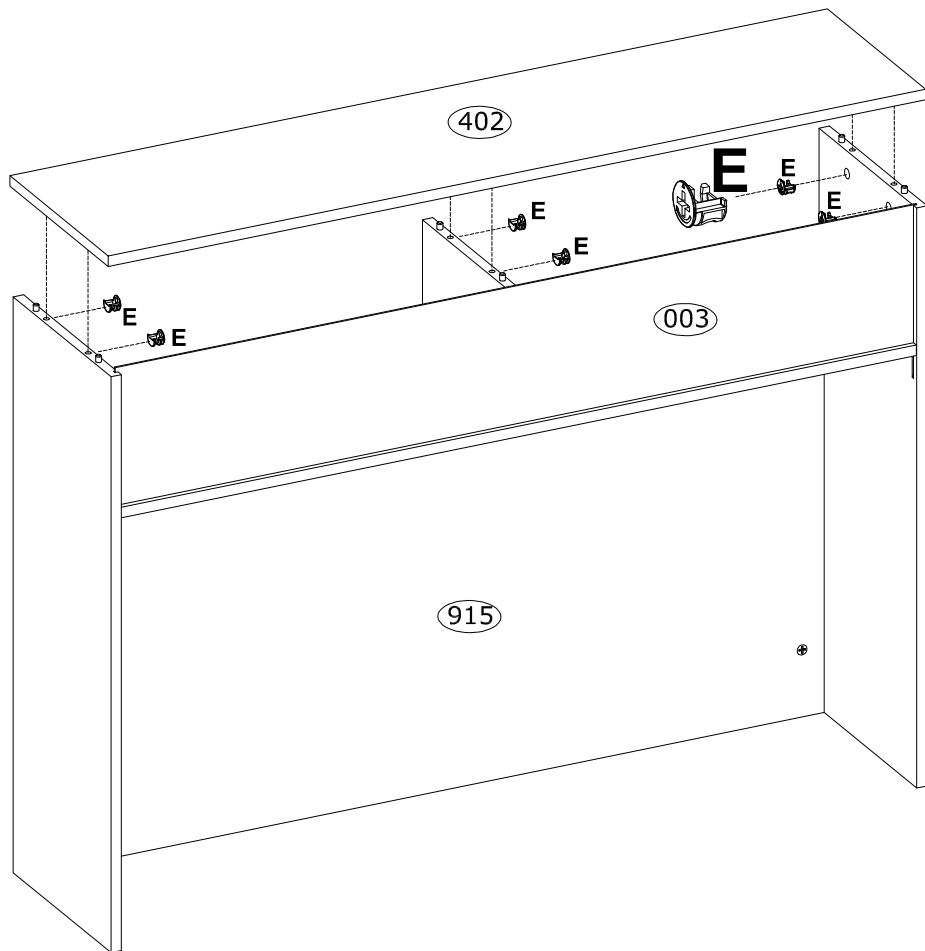
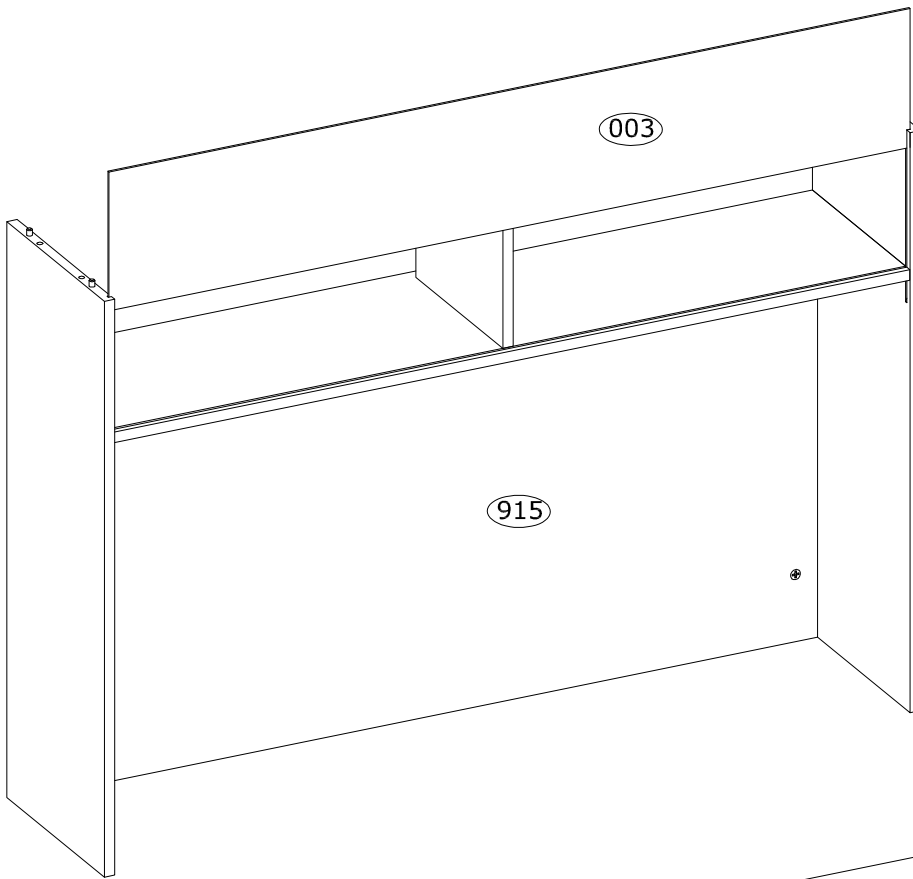
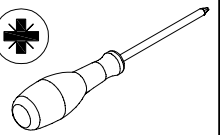

16

E
Ø15x12 mm
x6
3996

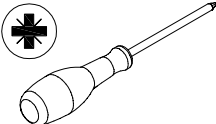

17

S 15x14x11 mm  x6 4044	K Ø3,0x25 mm  x1 3892	
---	--	--

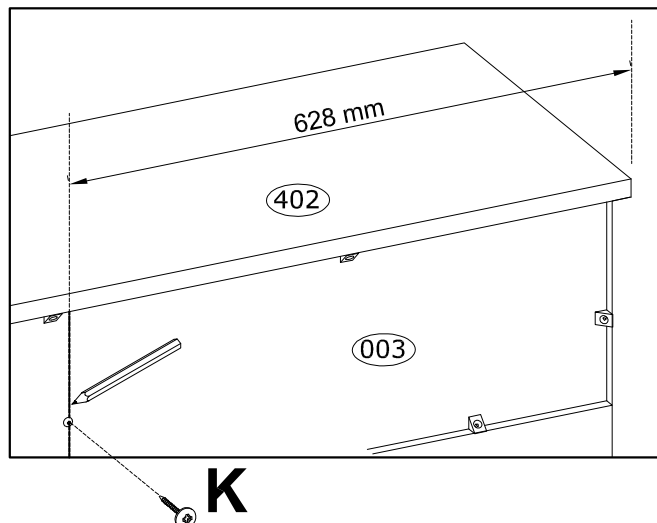
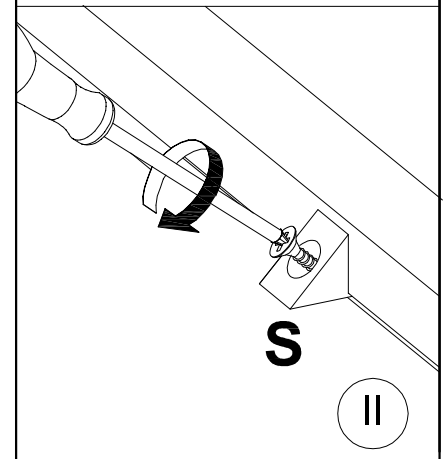
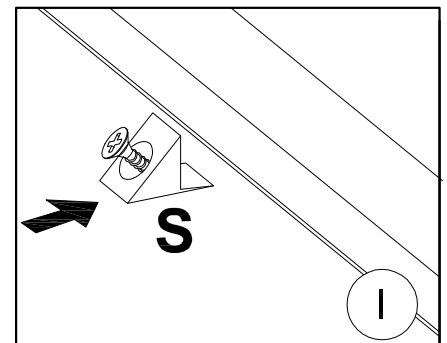
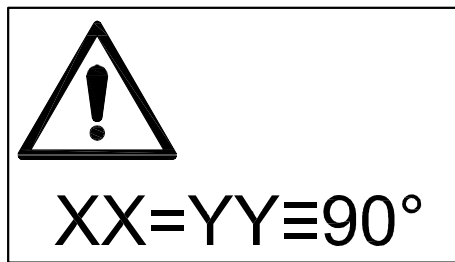
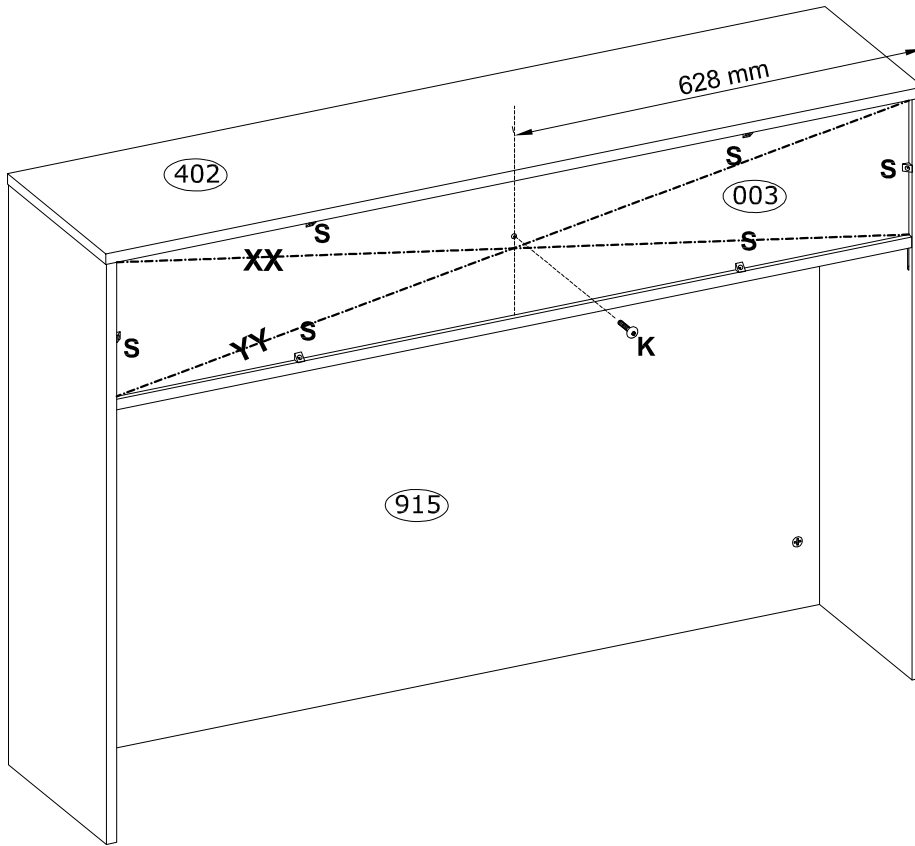

18

C
Ø6,5x36,5 mm
x4
4066

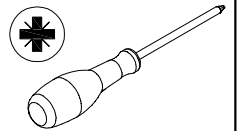

PINIO 90L

PINIO 90R

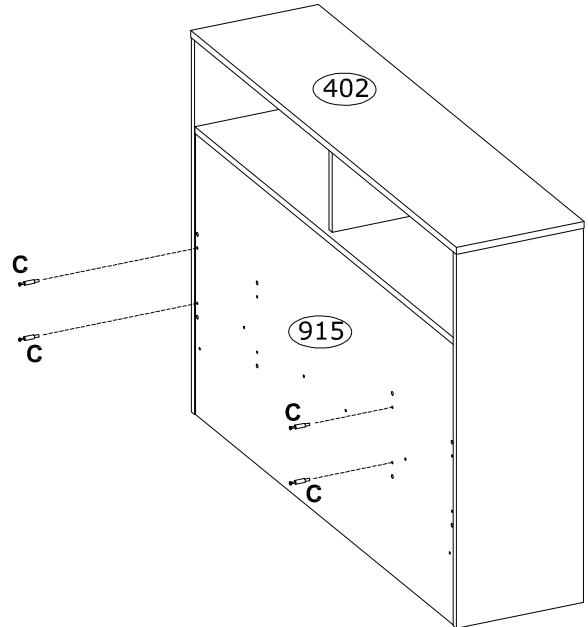
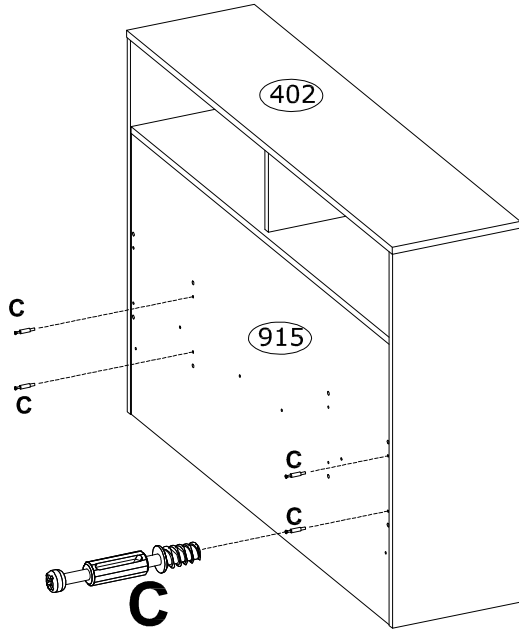
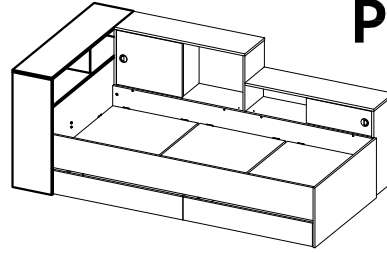
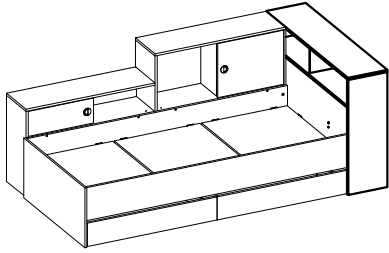

19

E
Ø15x12 mm
x4
3996

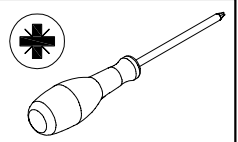
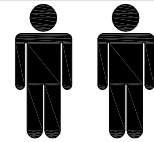

PINIO 90L

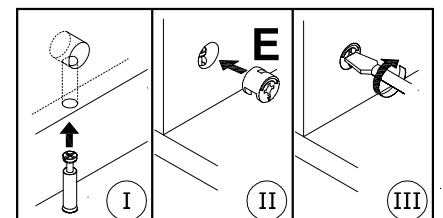
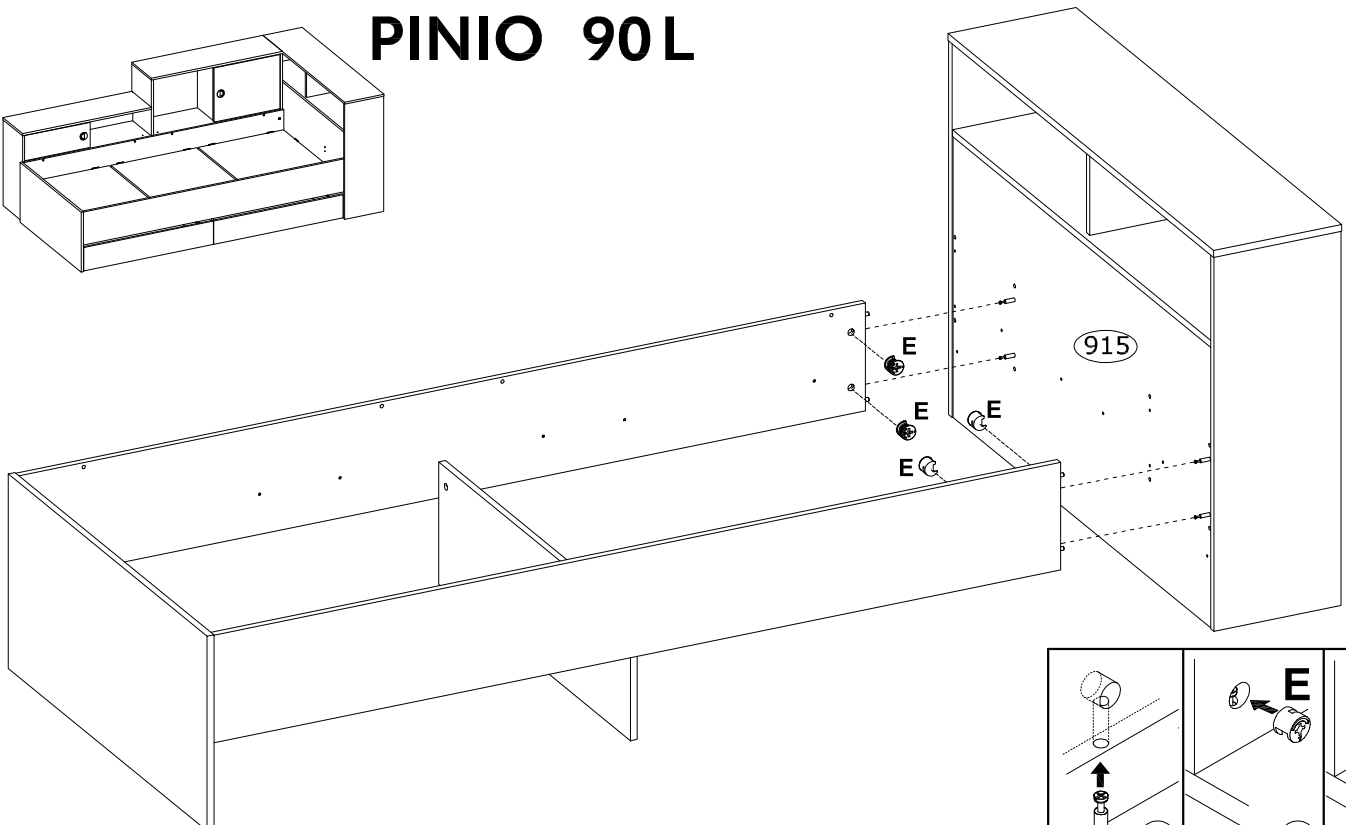
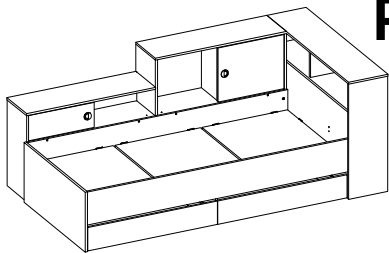

PINIO 90R

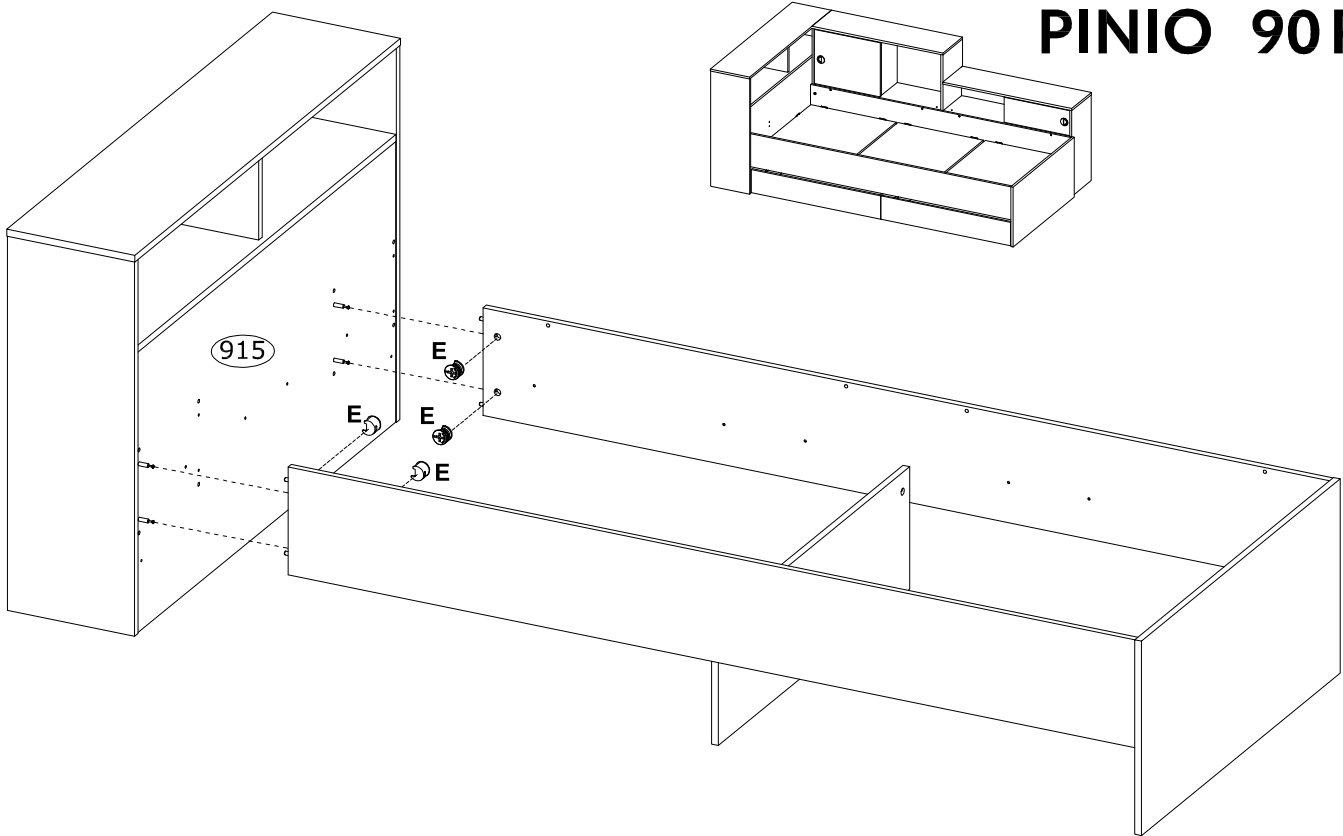

20

T	50x22x22 mm	J	Ø4,0x16 mm		
	x16 121897		x32 3923		

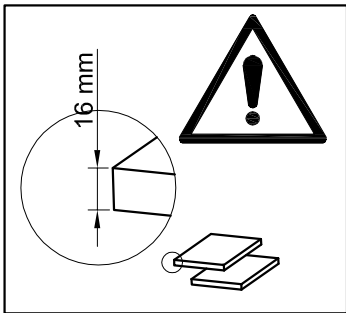

PINIO 90L
PINIO 90R

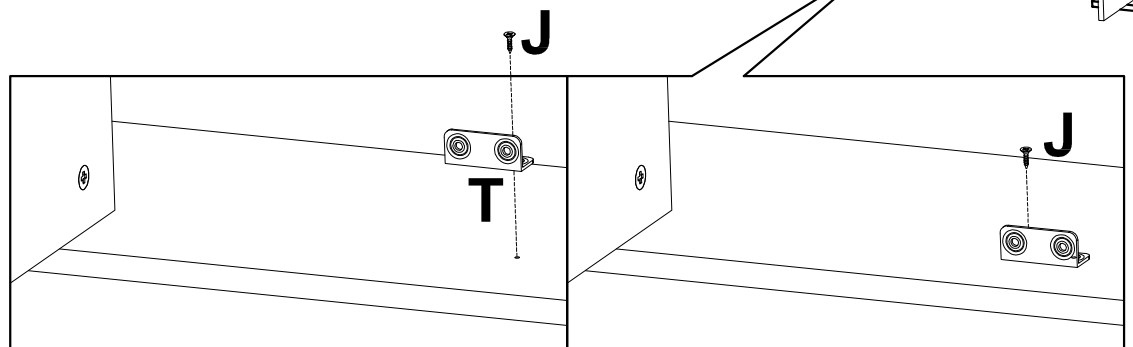
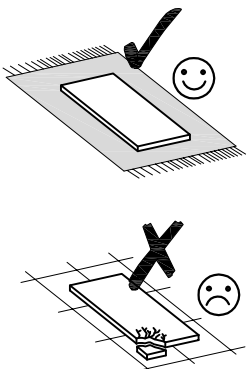
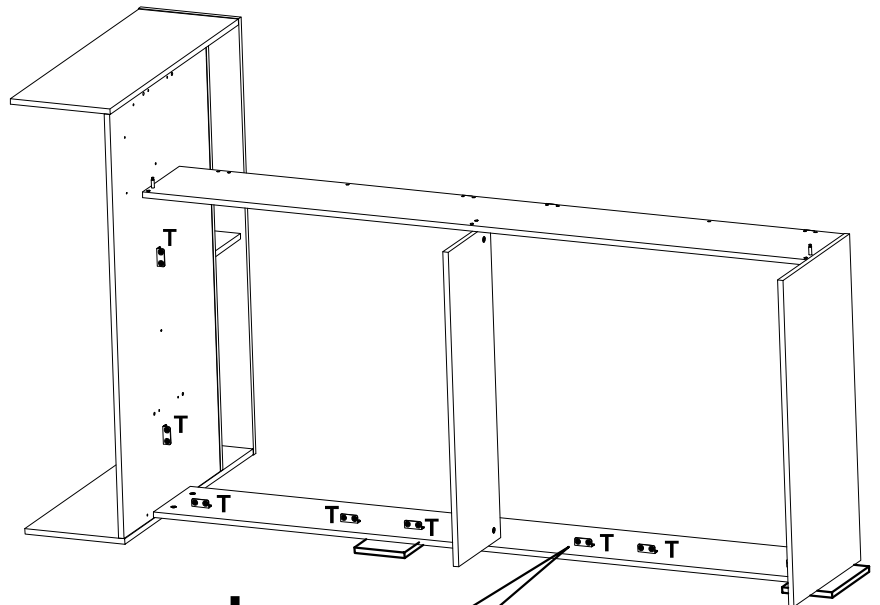

21

J $\varnothing 4,0 \times 16$ mm
x32
3923

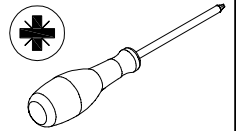

PINIO 90 L | PINIO 90 R

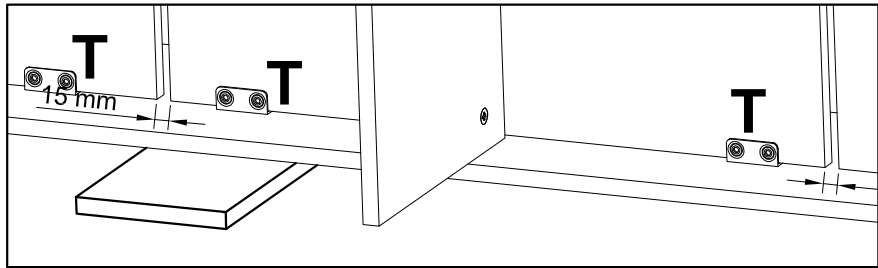
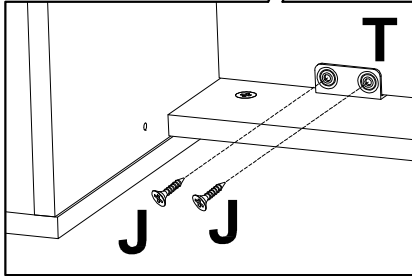
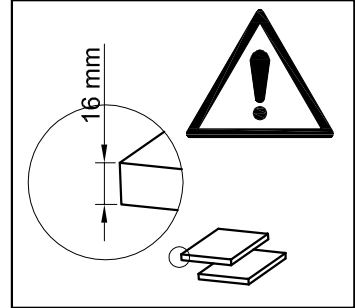
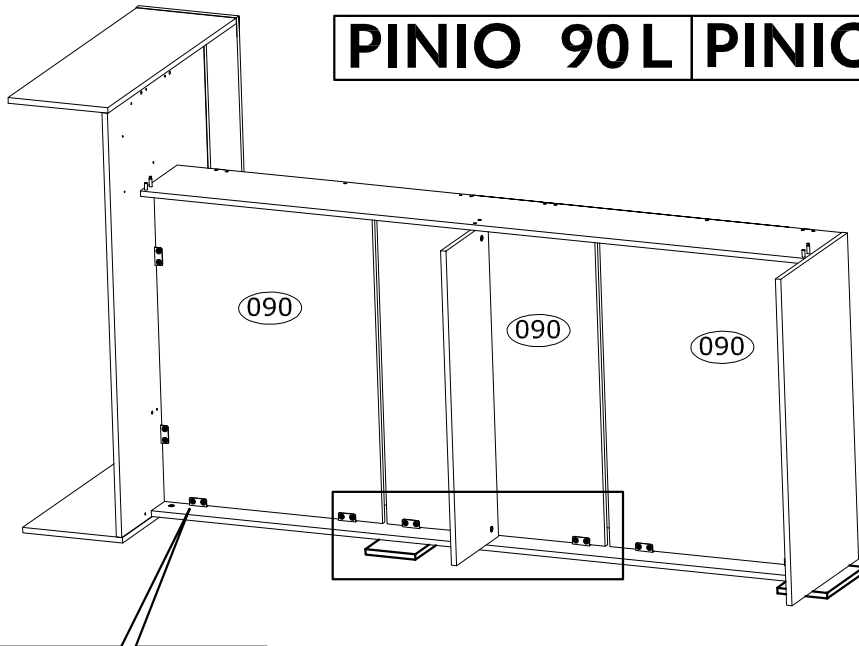
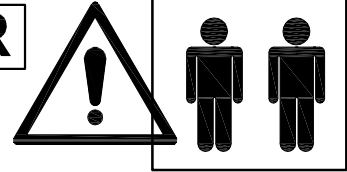

22

D $\varnothing 6,5 \times 36,5$ mm
x4
266394

A $\varnothing 8 \times 30$ mm
x2
3989

P
x2
90907

H $18 \times 18 \times 14$ mm
x2
243136

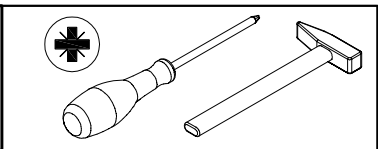

J $\varnothing 4,0 \times 16$ mm
x2
3923

PINIO 90 L

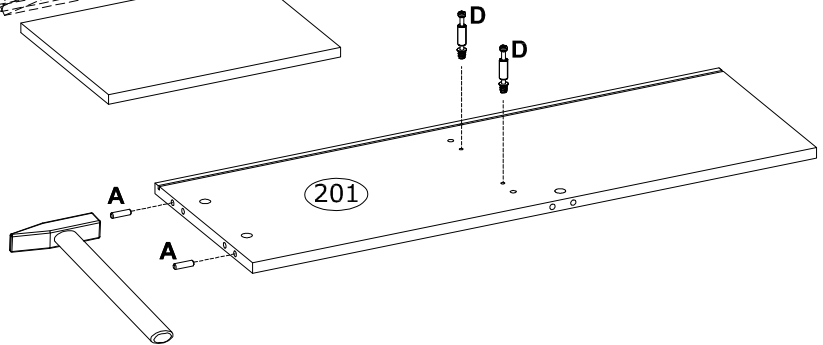
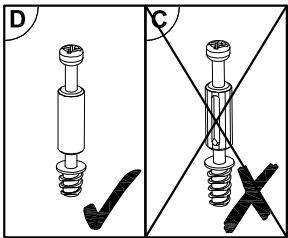
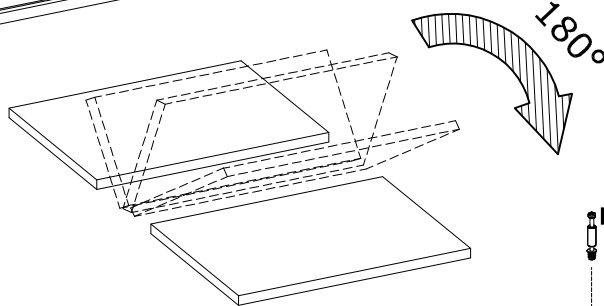
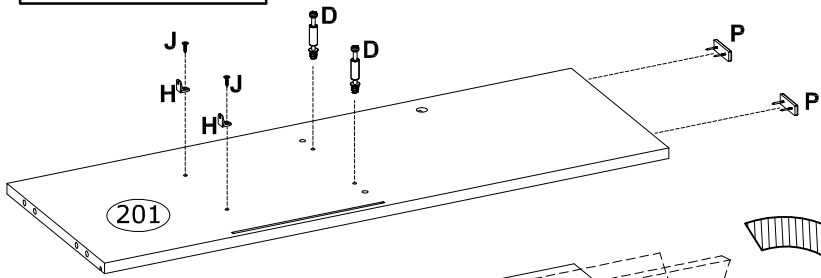
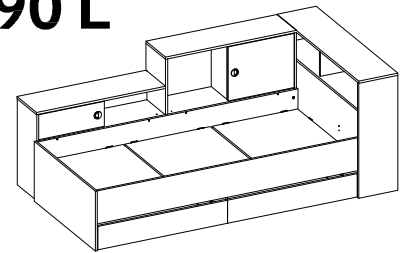

PINIO 90 L

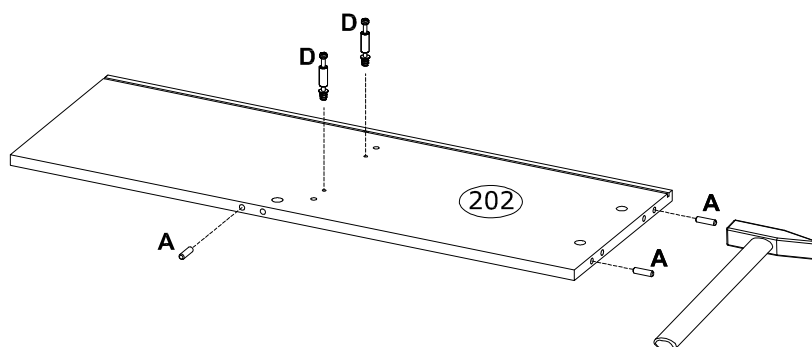
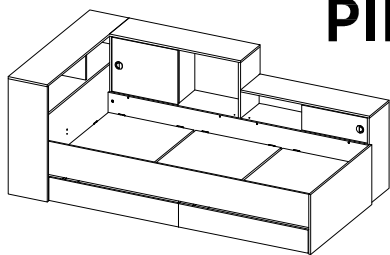

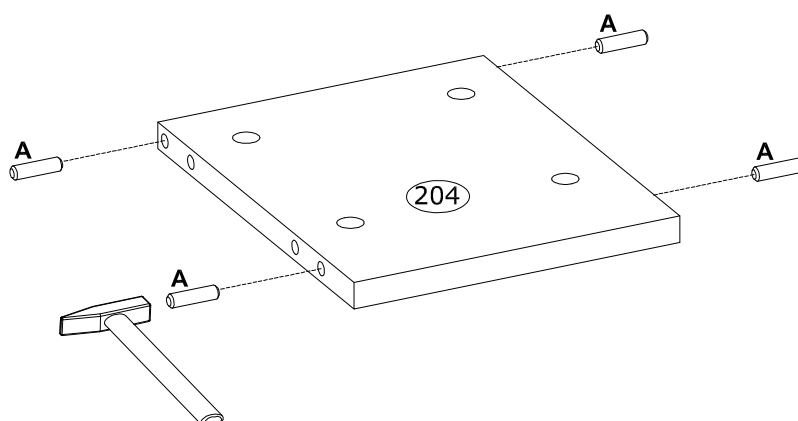

23

A	Ø8x30 mm		
	x4		
	3989		
			



24

Z L-972 mm x2 253721	B1 Ø3,0x13 mm x8 3923	A Ø8x30 mm x10 3989	C Ø6,5x36,5 mm x4 4066	 
--------------------------------------	---------------------------------------	-------------------------------------	--	--

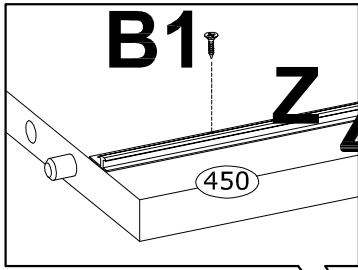

x2

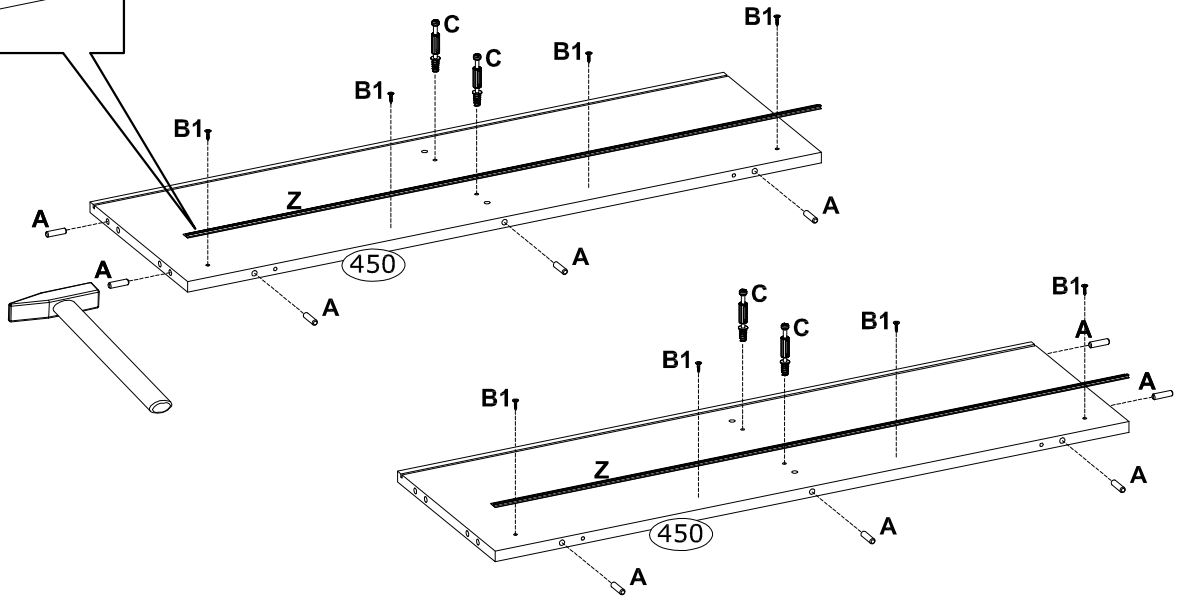

25

Z L-972 mm x1 253721	B1 Ø3,0x13 mm x4 3923	C Ø6,5x36,5 mm x4 4066	
--------------------------------------	---------------------------------------	--	---

PINIO 90L

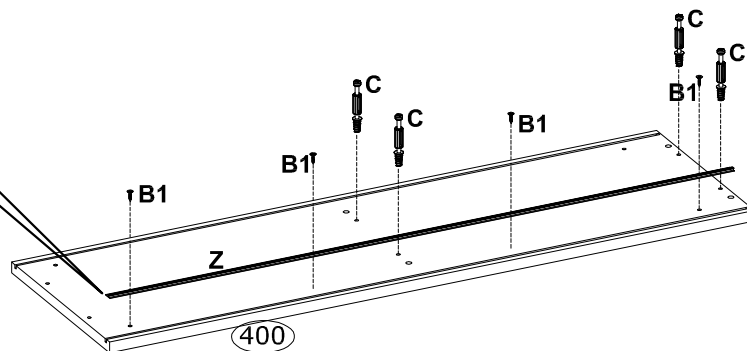
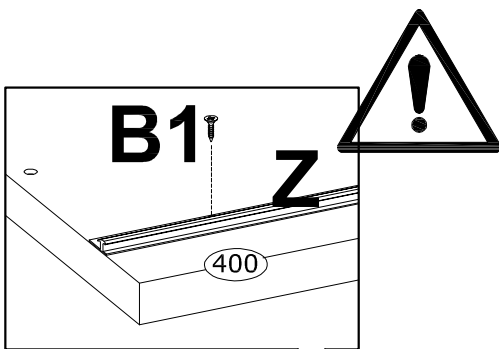
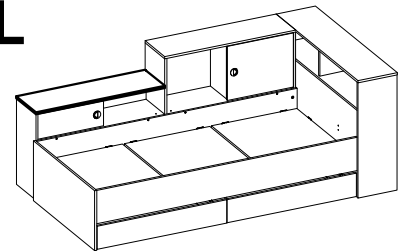

PINIO 90R

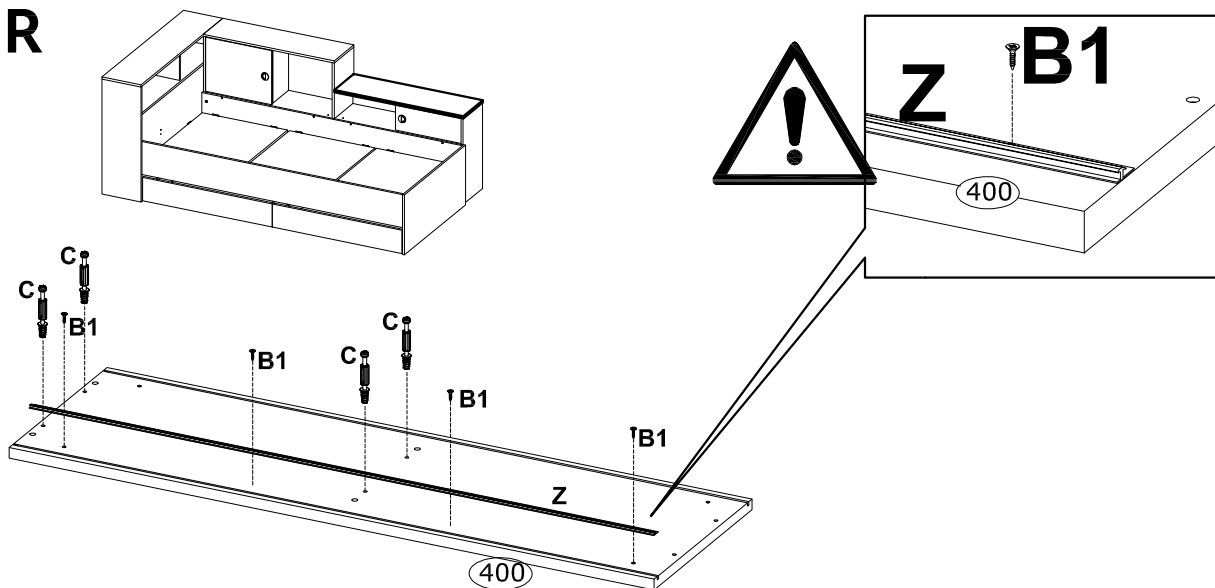

26

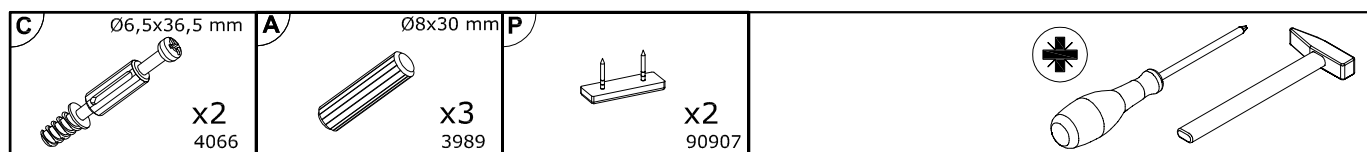

PINIO 90L

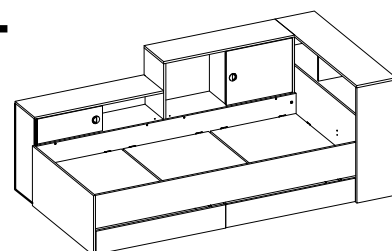
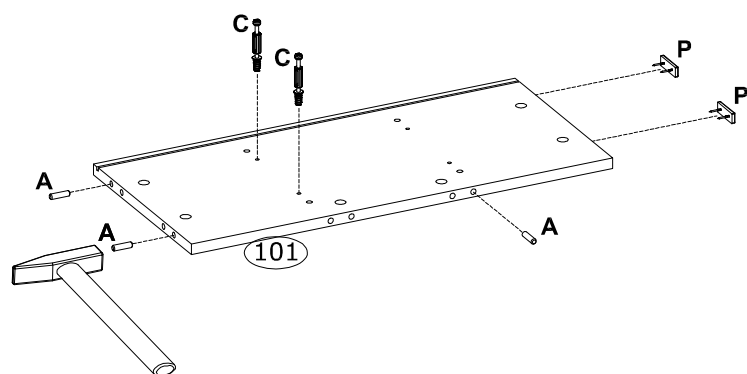

PINIO 90R

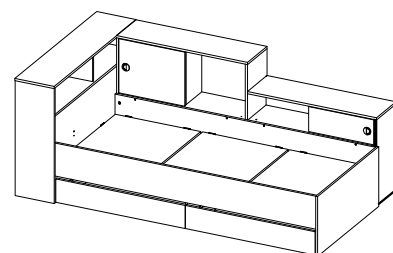
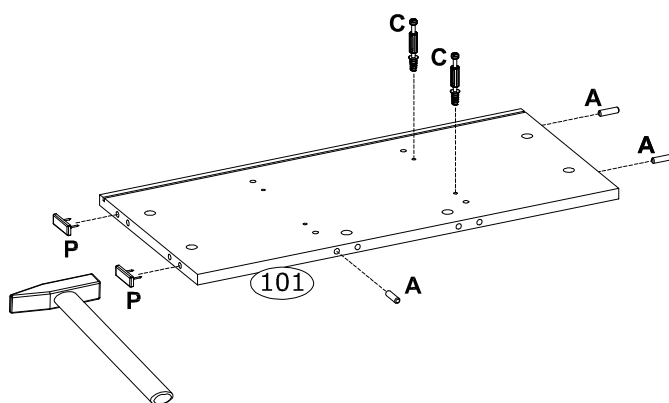

27

E
Ø15x12 mm
x4
3996

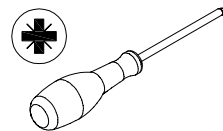

PINIO 90L

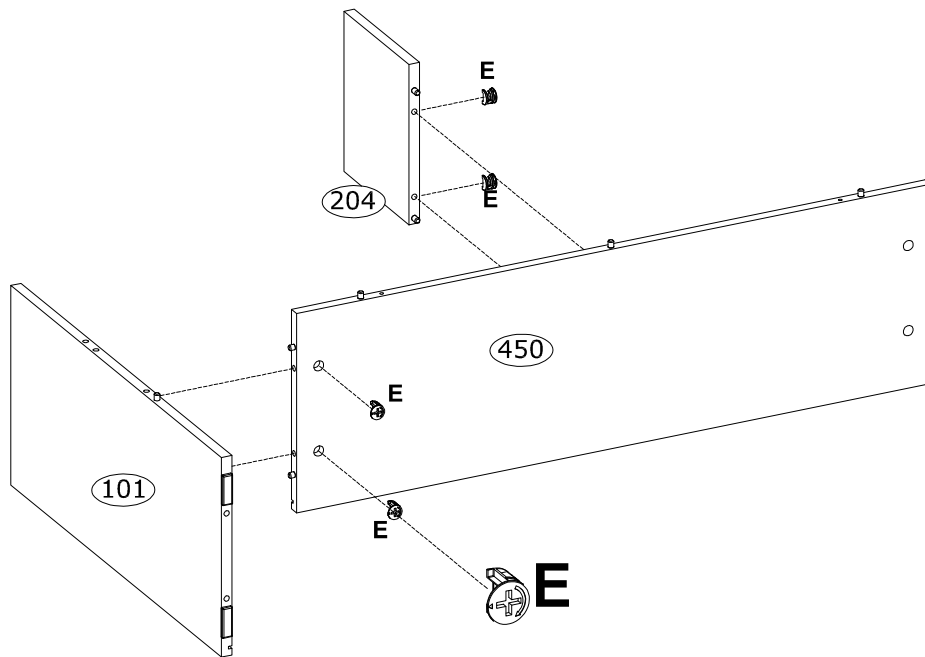
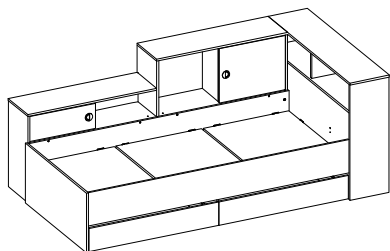

PINIO 90 R

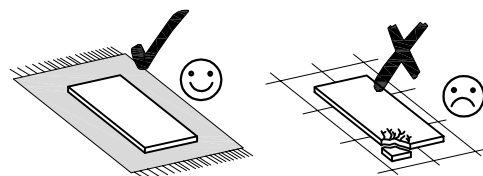
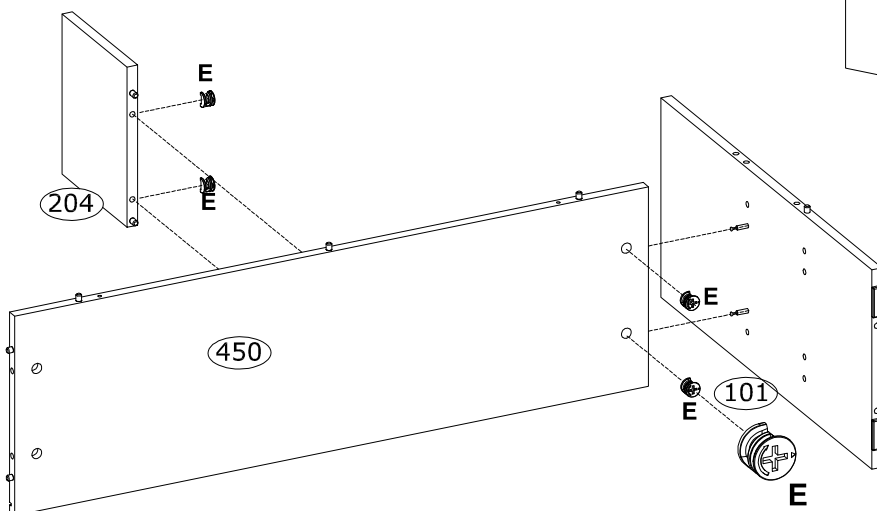
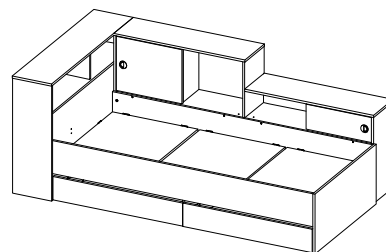

28

E
Ø15x12 mm
x4
3996

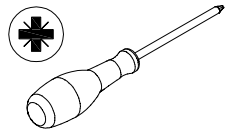

PINIO 90L

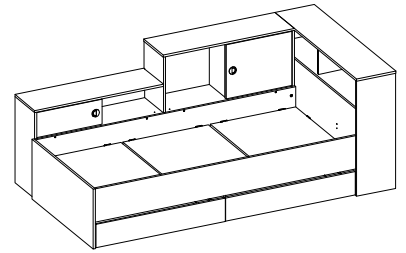
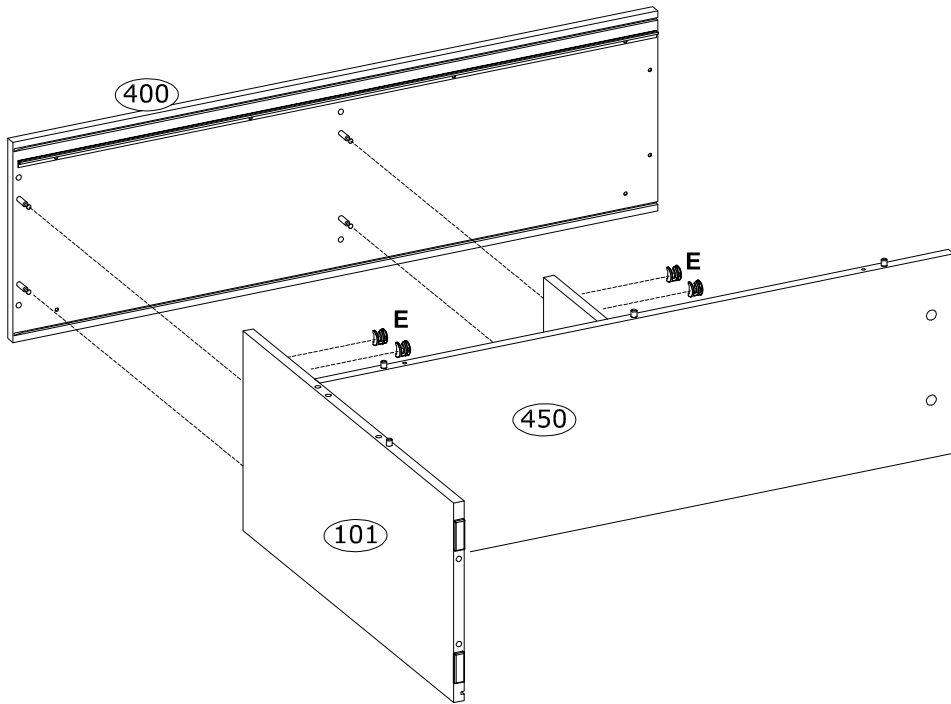

PINIO 90 R

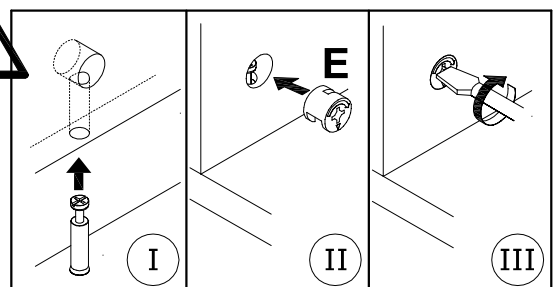
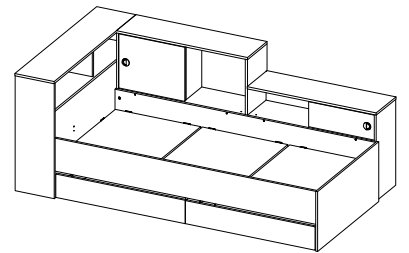
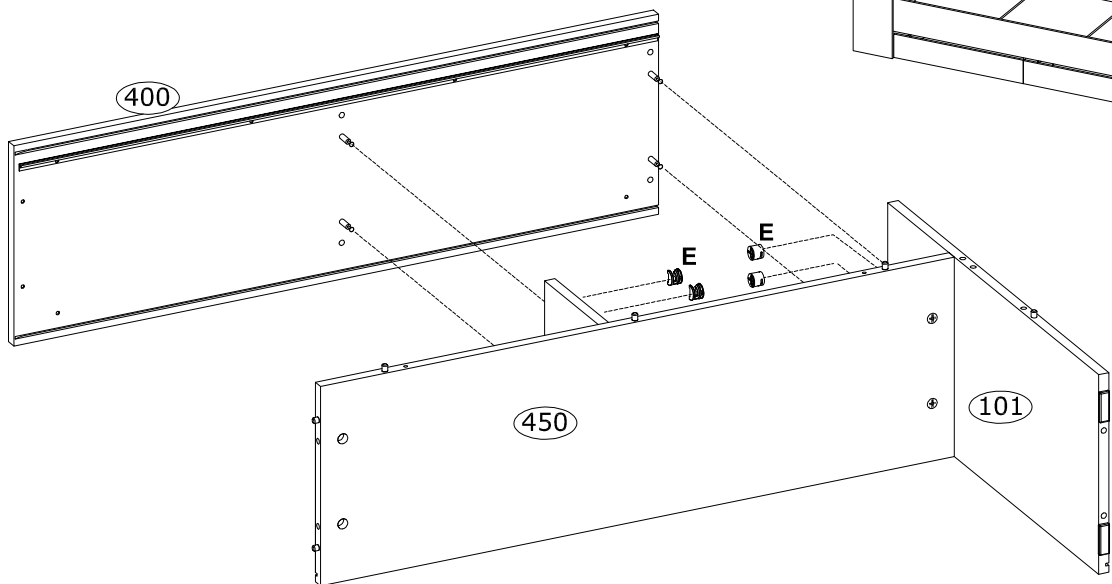

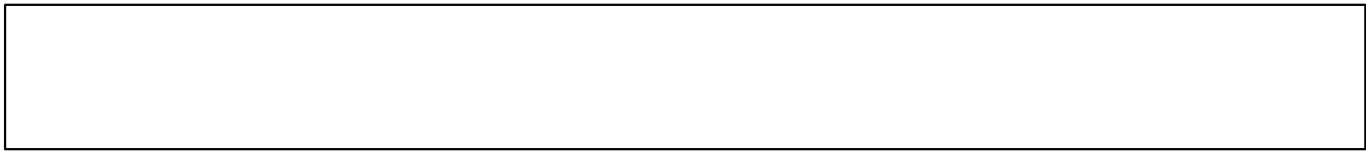

PINIO 90 L

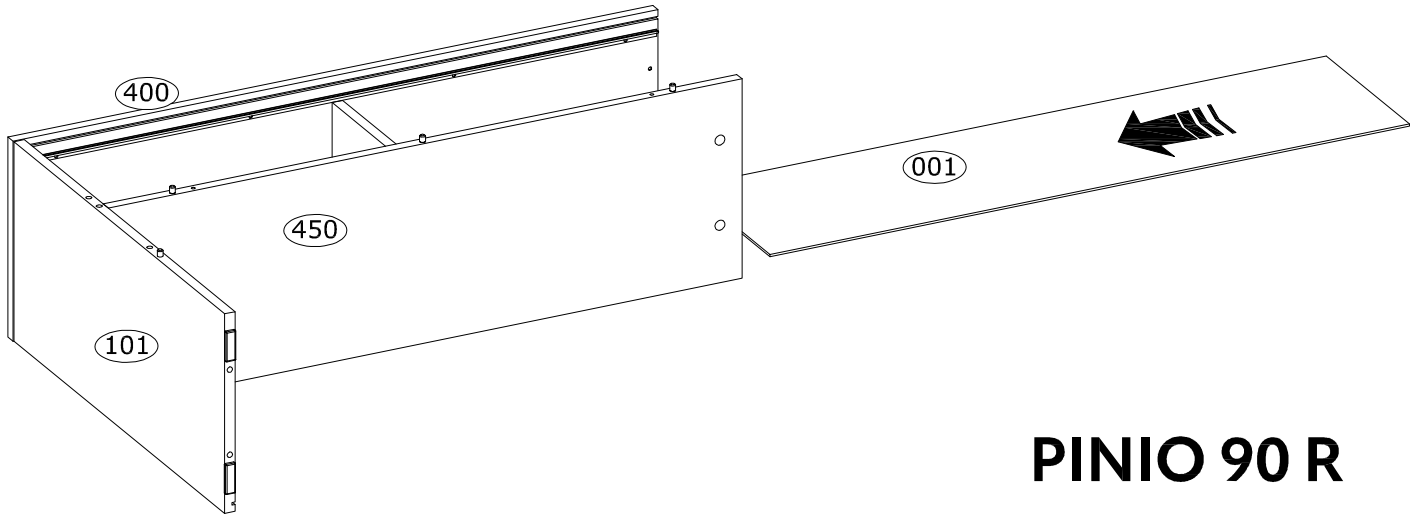
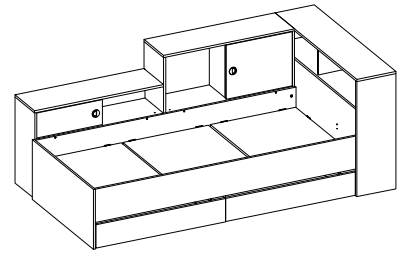

PINIO 90 R

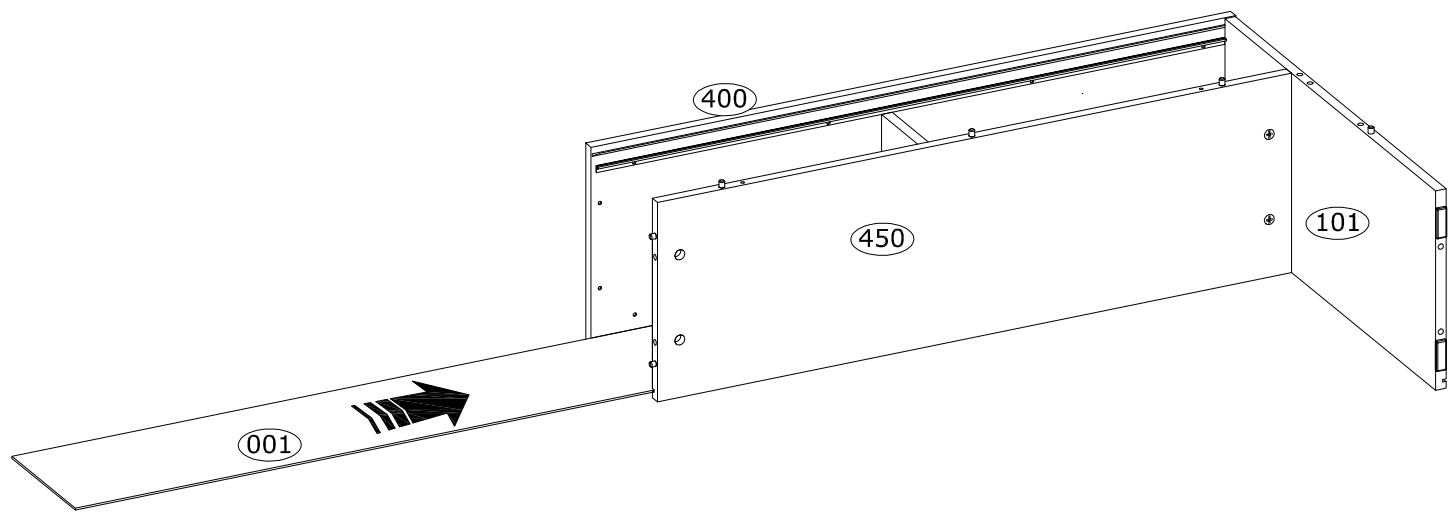
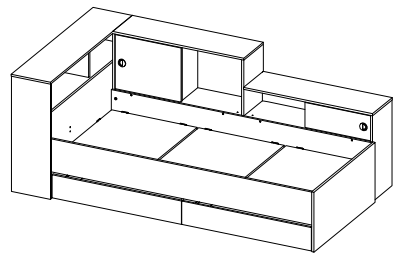

30

E Ø15x12 mm x2 3996

J Ø4,0x16 mm x2 3923

B Ø8x50 mm x2 3991

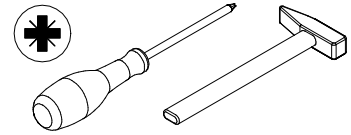

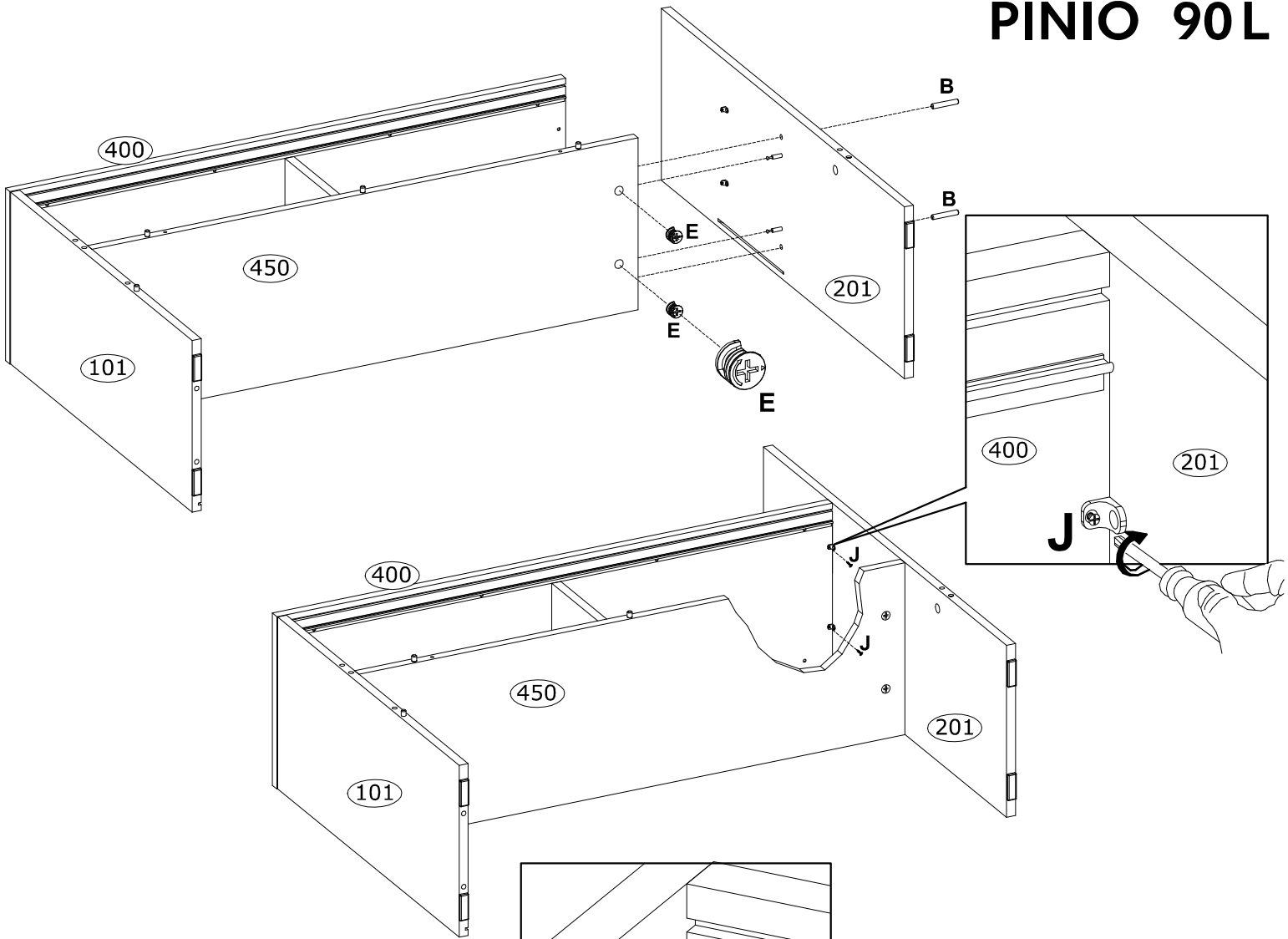

PINIO 90 L

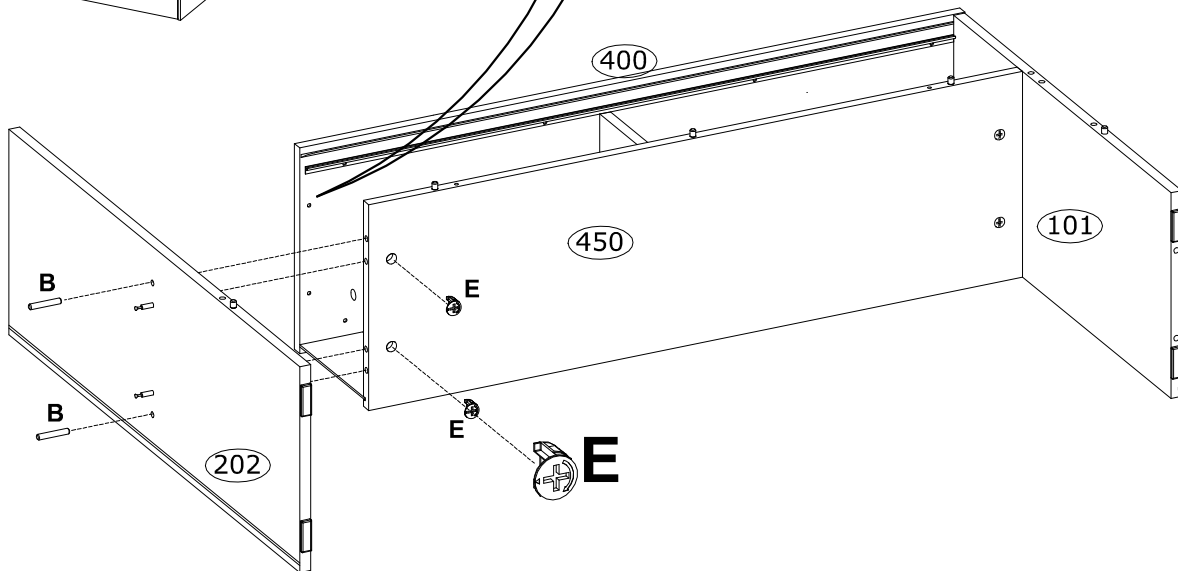
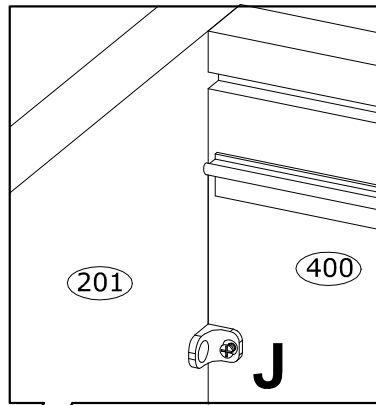
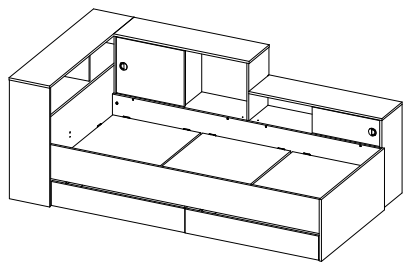

PINIO 90 R

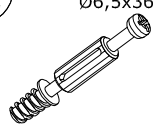
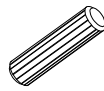

31

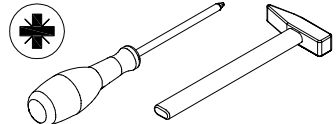
C Ø6,5x36,5 mm  x2 4066	A Ø8x30 mm  x3 3989	P  x2 90907	
--	--	---	--

PINIO 90 R

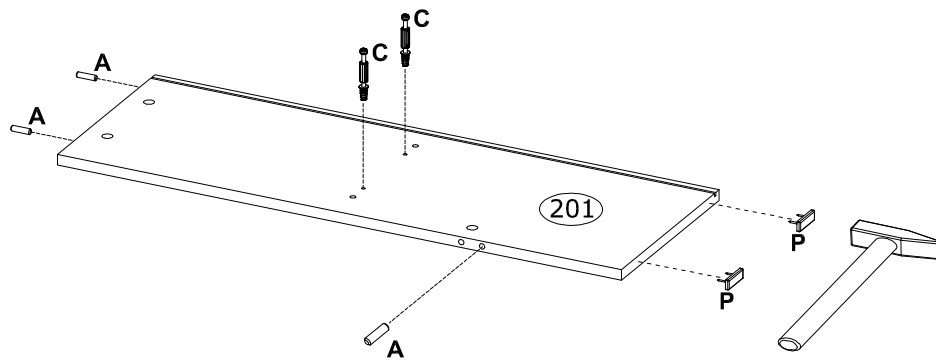
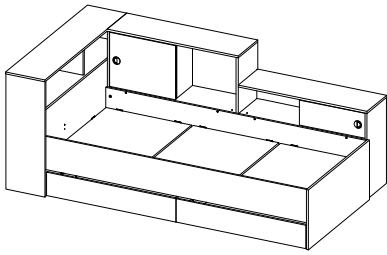



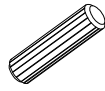
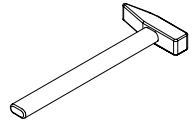

32

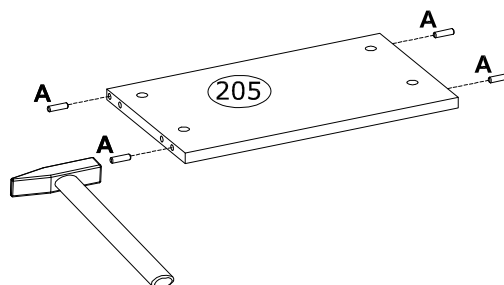
A Ø8x30 mm  x4 3989	
---	---

PINIO 90L PINIO 90R

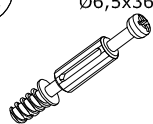

33

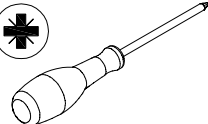
C Ø6,5x36,5 mm  x6 4066	Z L-972 mm  x1 253721	B1 Ø3,0x13 mm  x4 3923	 
--	--	---	--

PINIO 90L | PINIO 90R

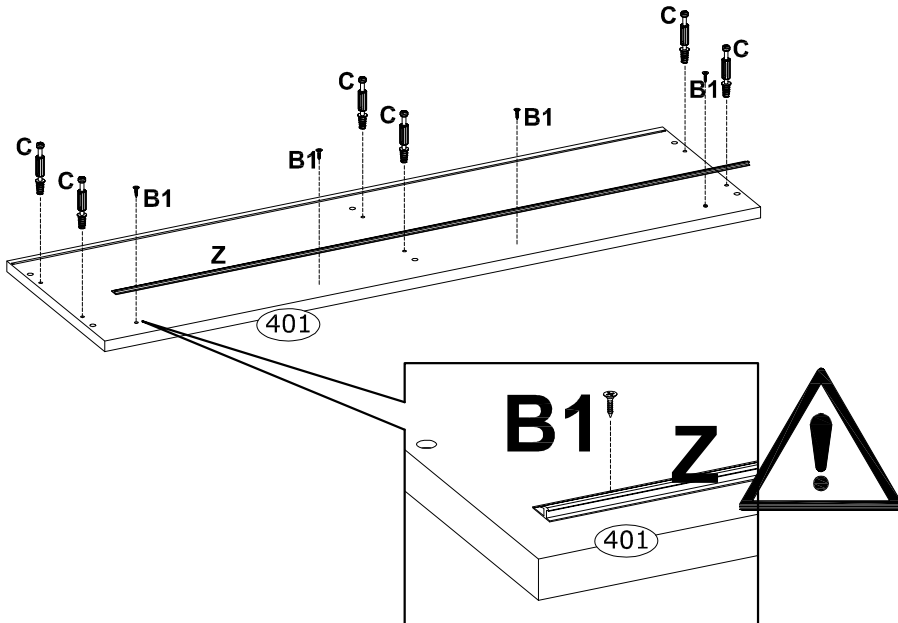

34

E Ø15x12 mm  x4 3996	 
---	--

PINIO 90L

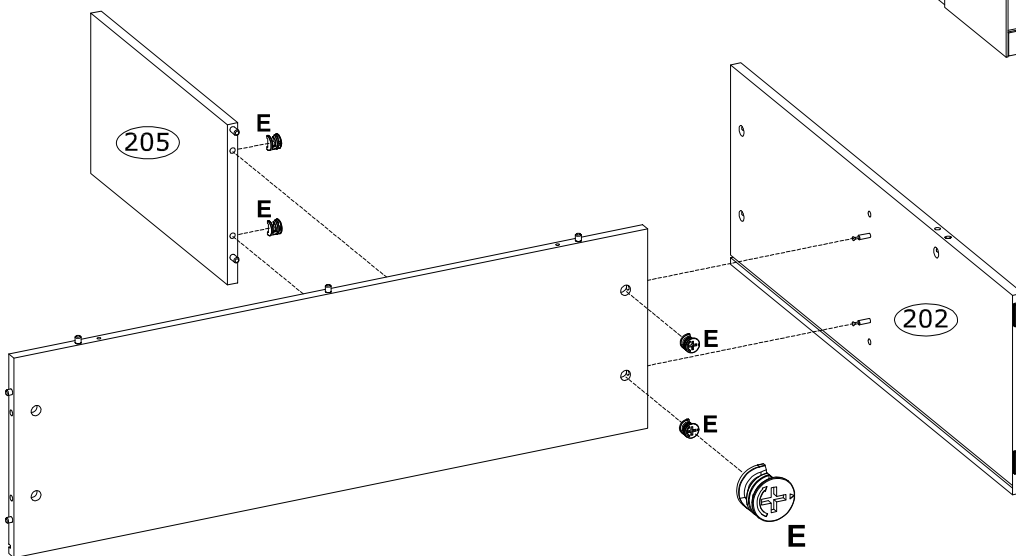
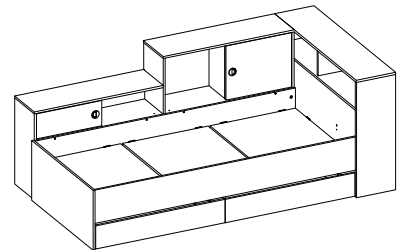

PINIO 90 R

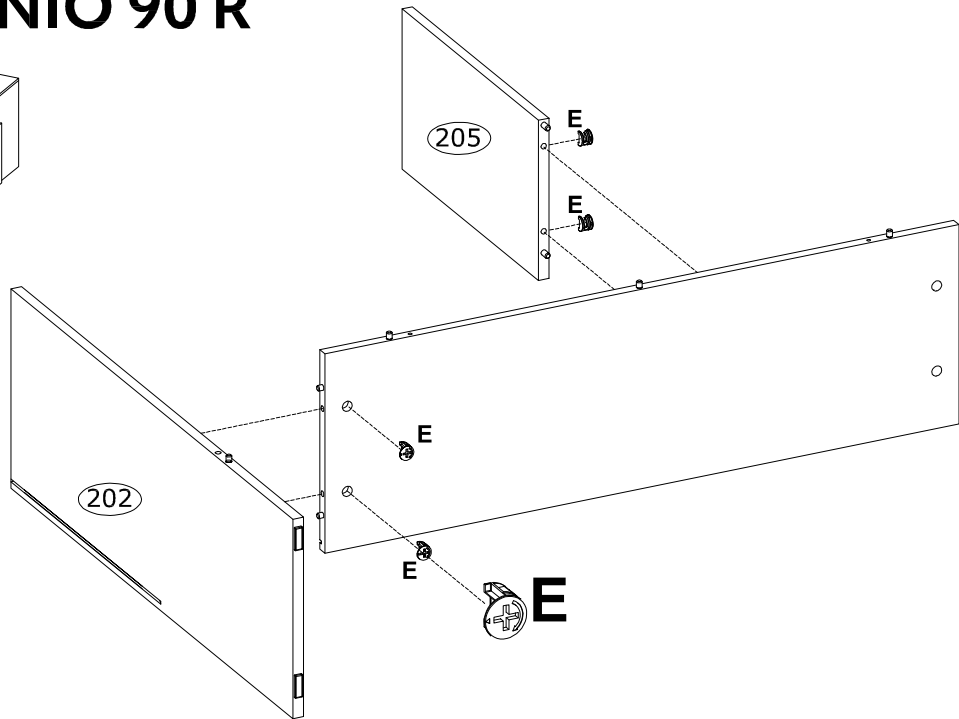
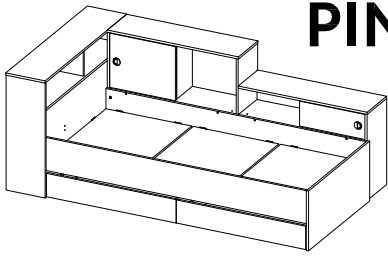

35

E	Ø15x12 mm	 x2 3996		

PINIO 90 L

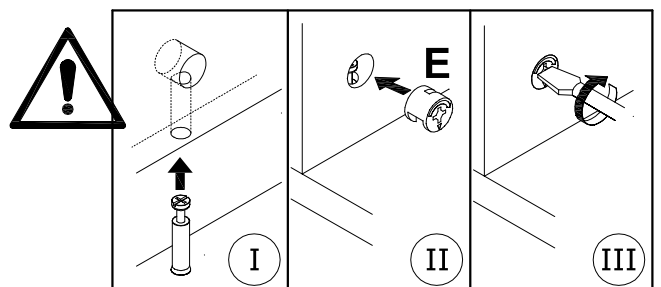
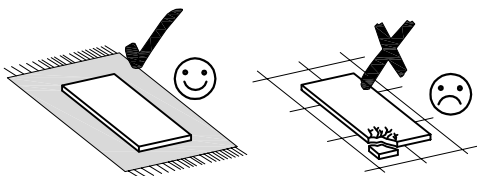
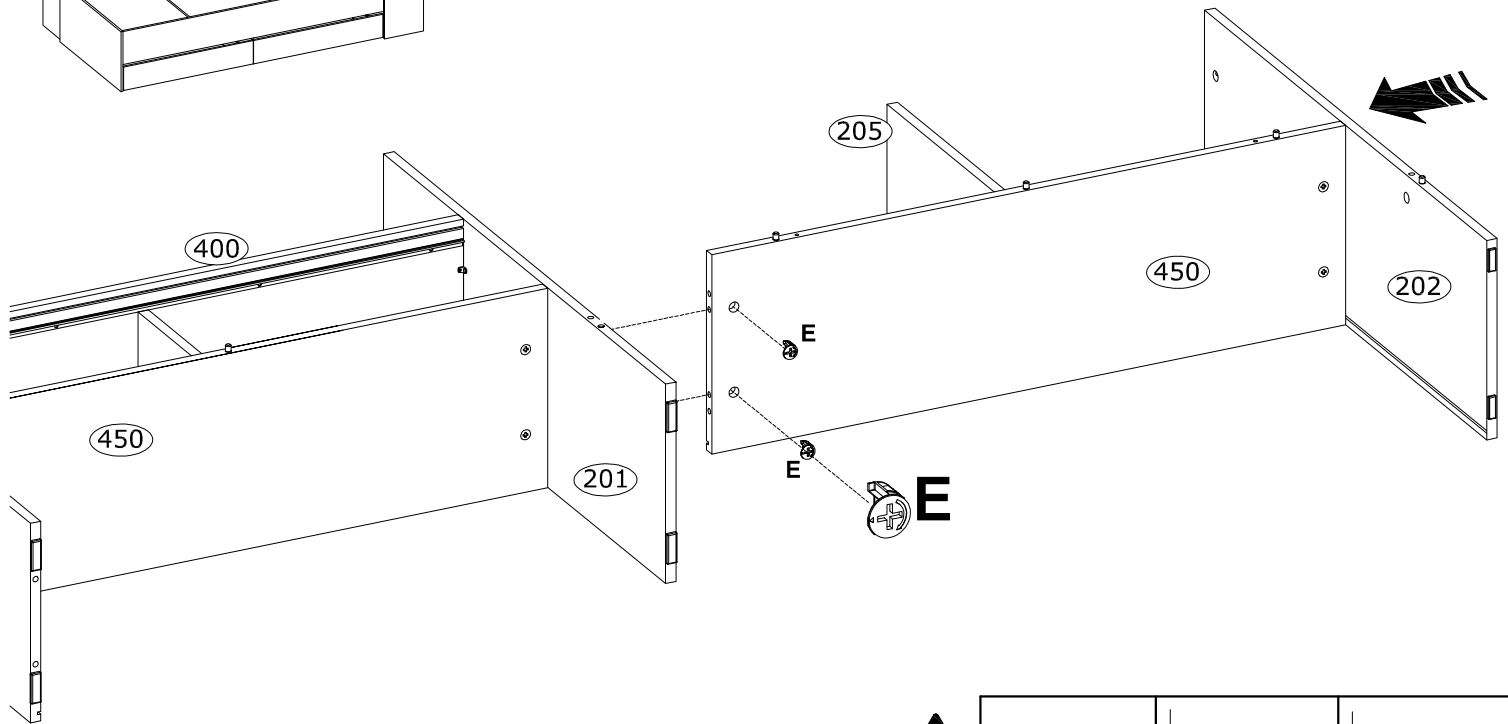
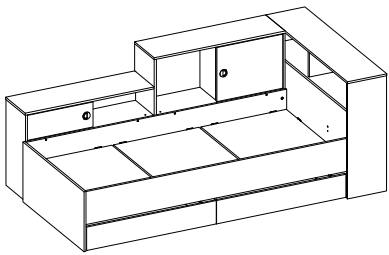

PINIO 90 R

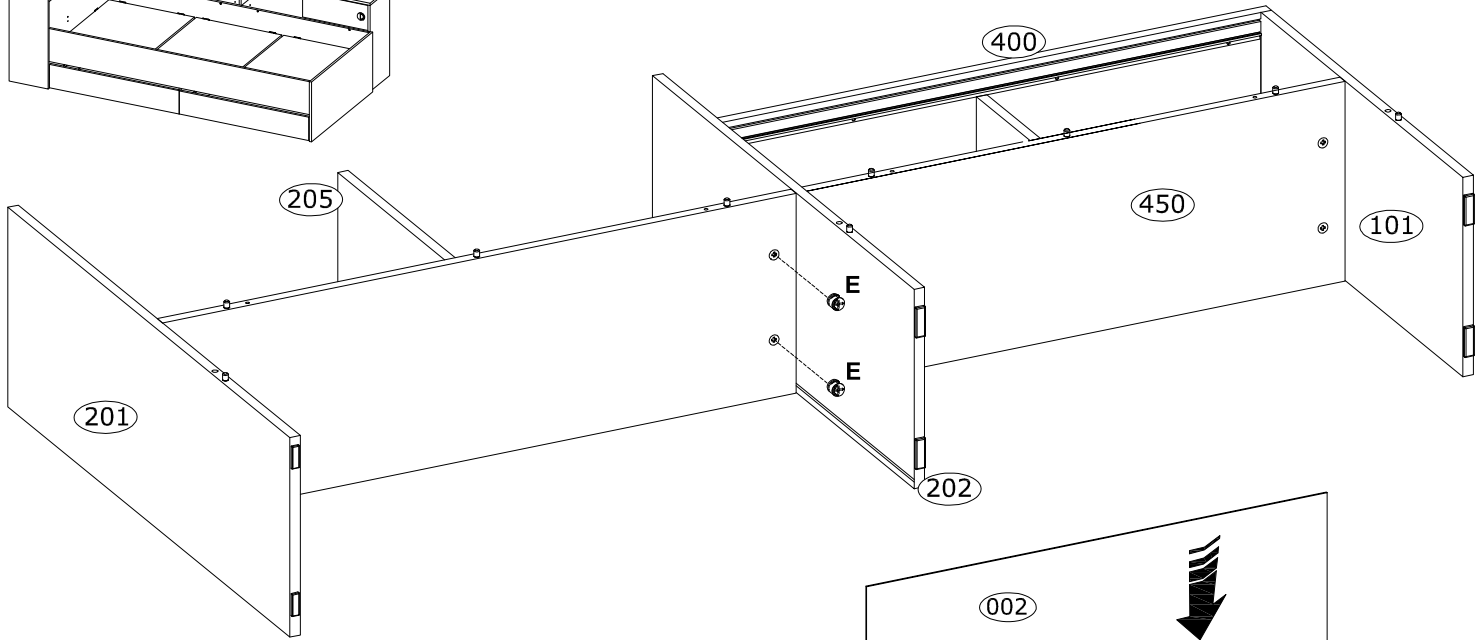
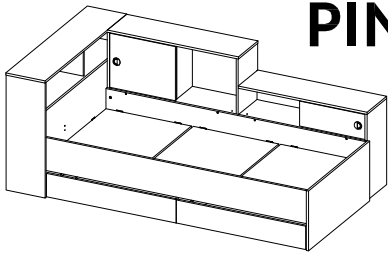

PINIO 90L

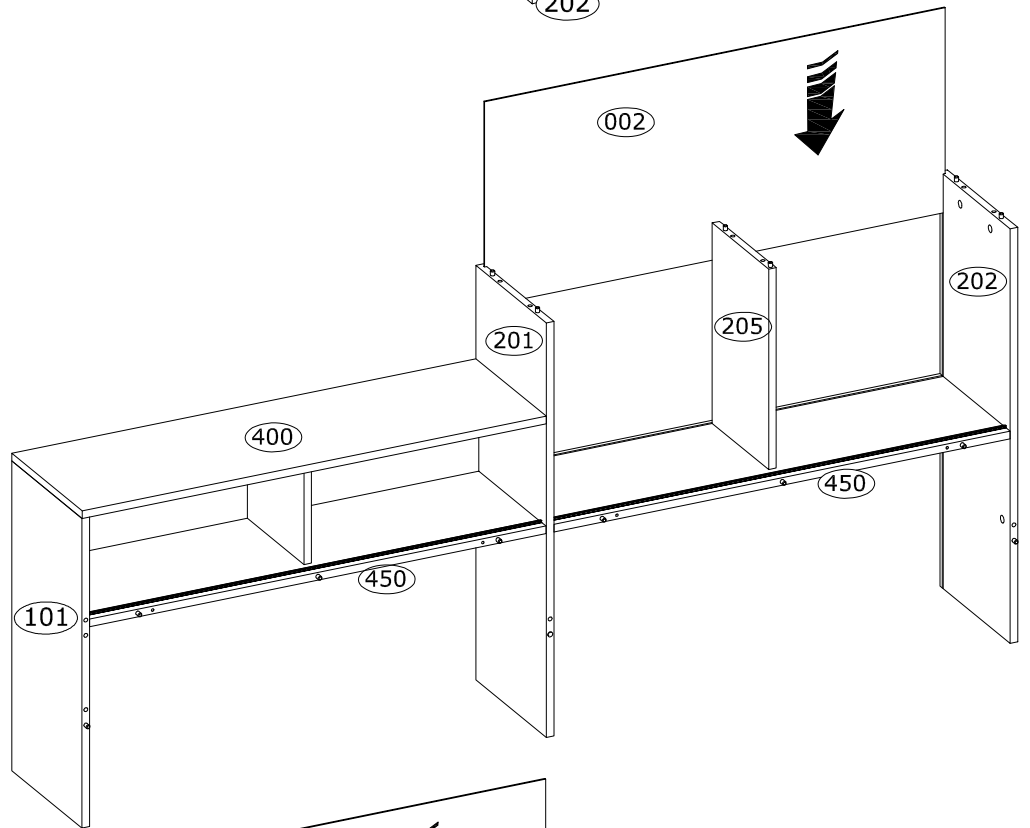
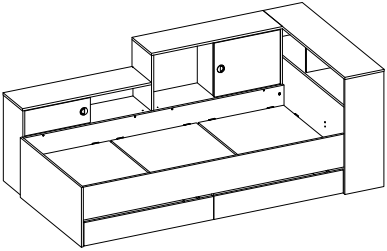

PINIO 90 R

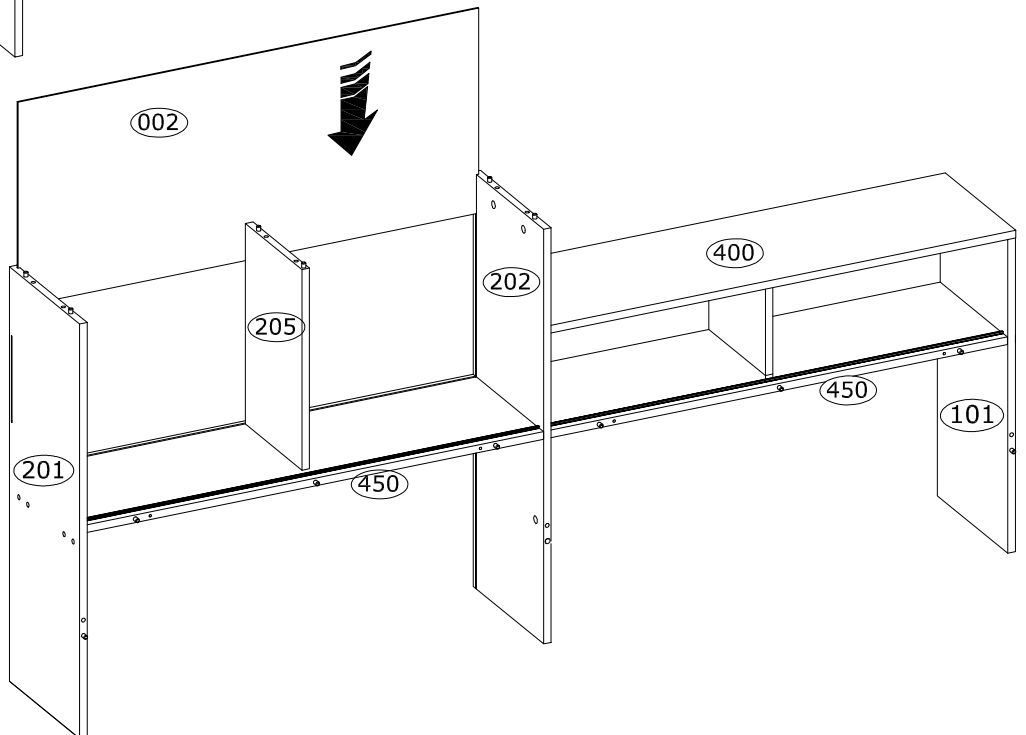
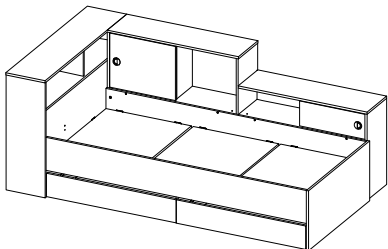

36

E
Ø15x12 mm
x6
3996

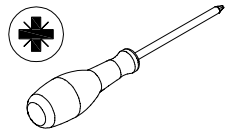

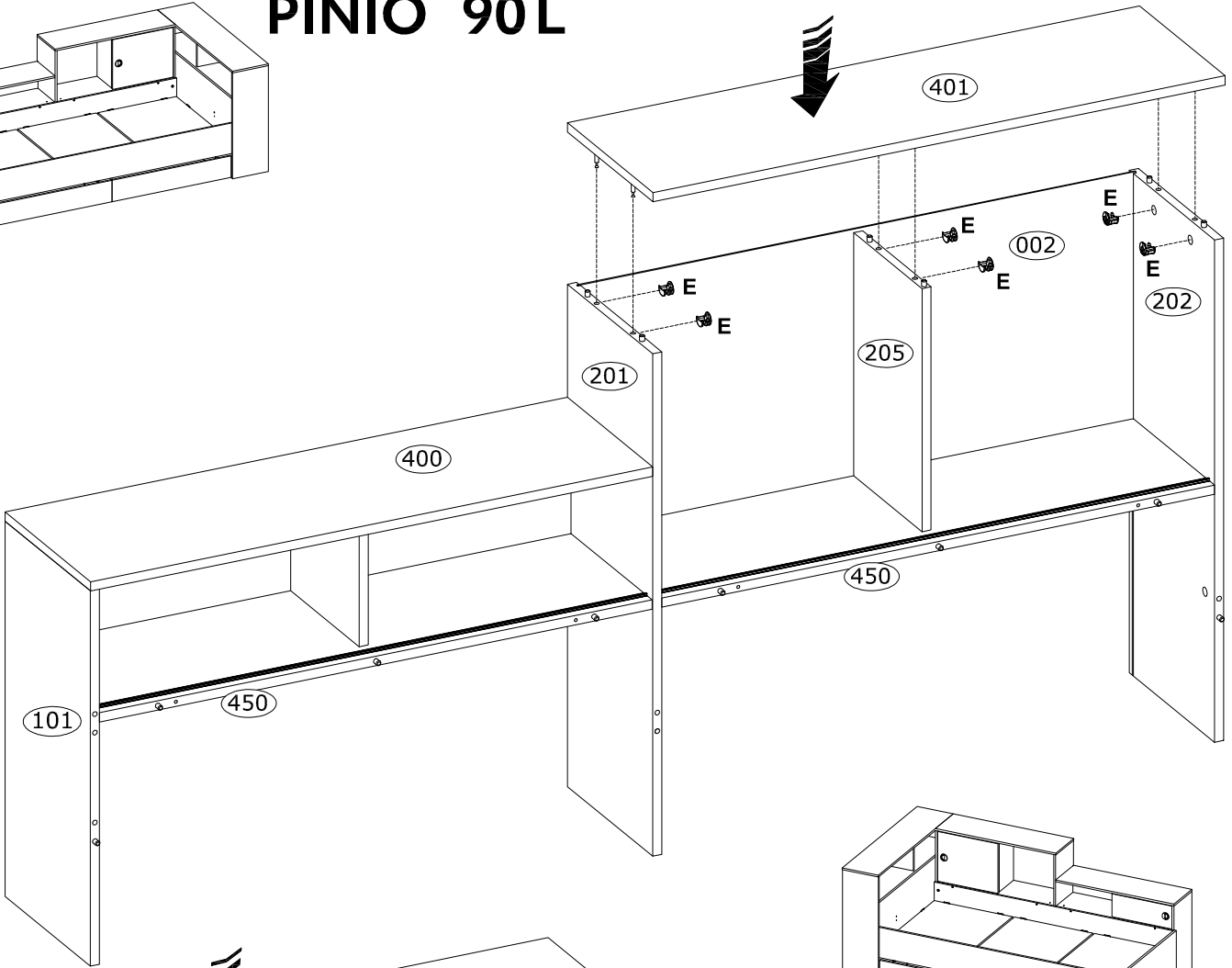
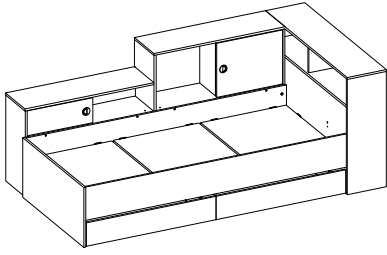

PINIO 90L

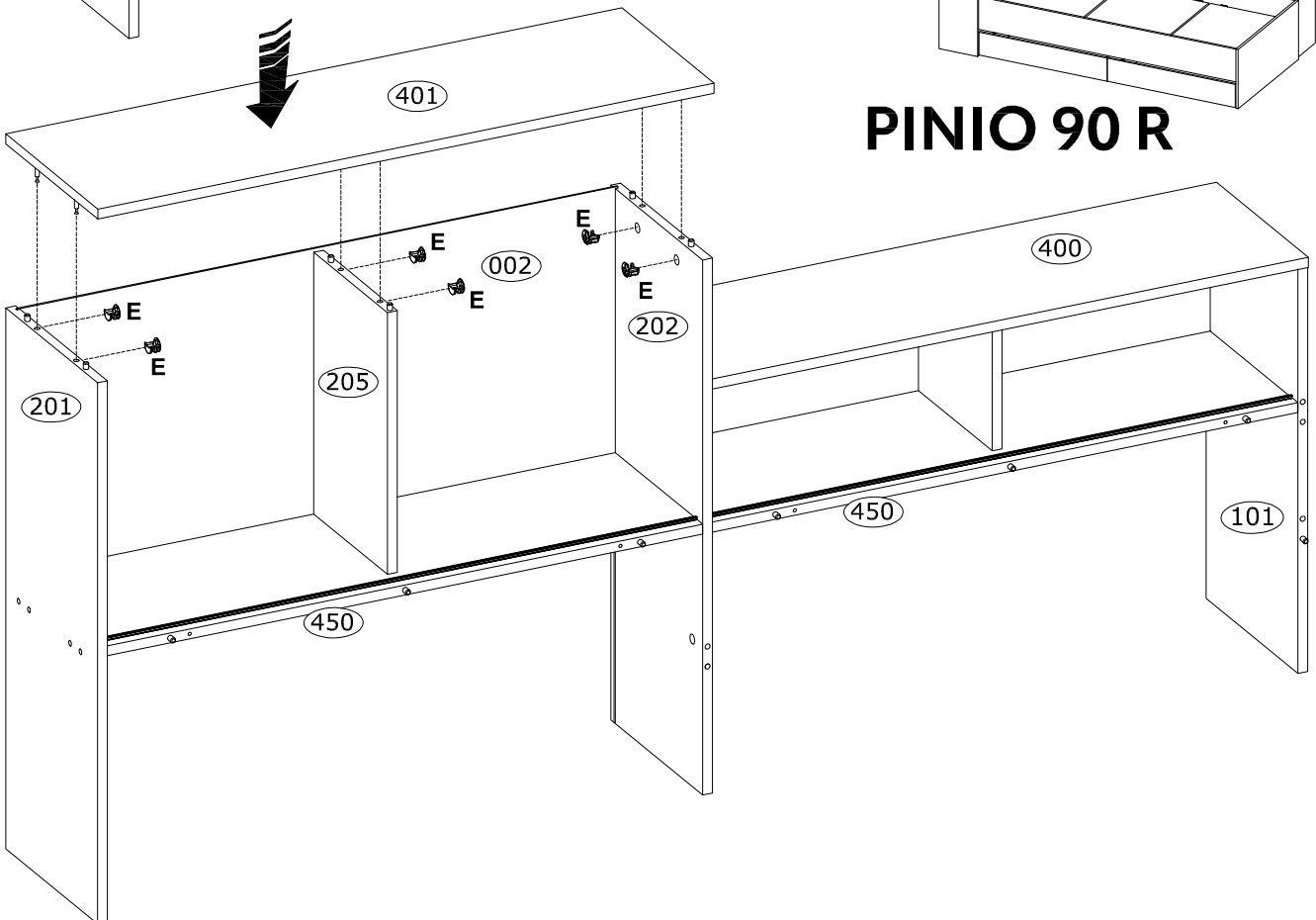
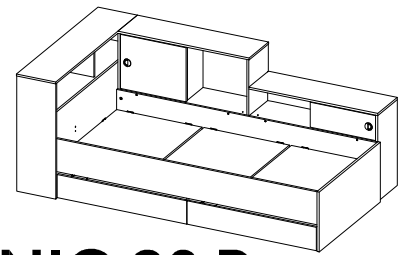

PINIO 90 R

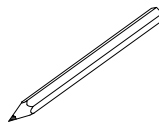
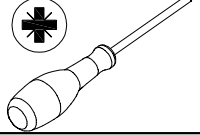

37

S 15x14x11 mm  x19 4044	K Ø3,0x25 mm  x4 3887	 
--	--	--

PINIO 90L

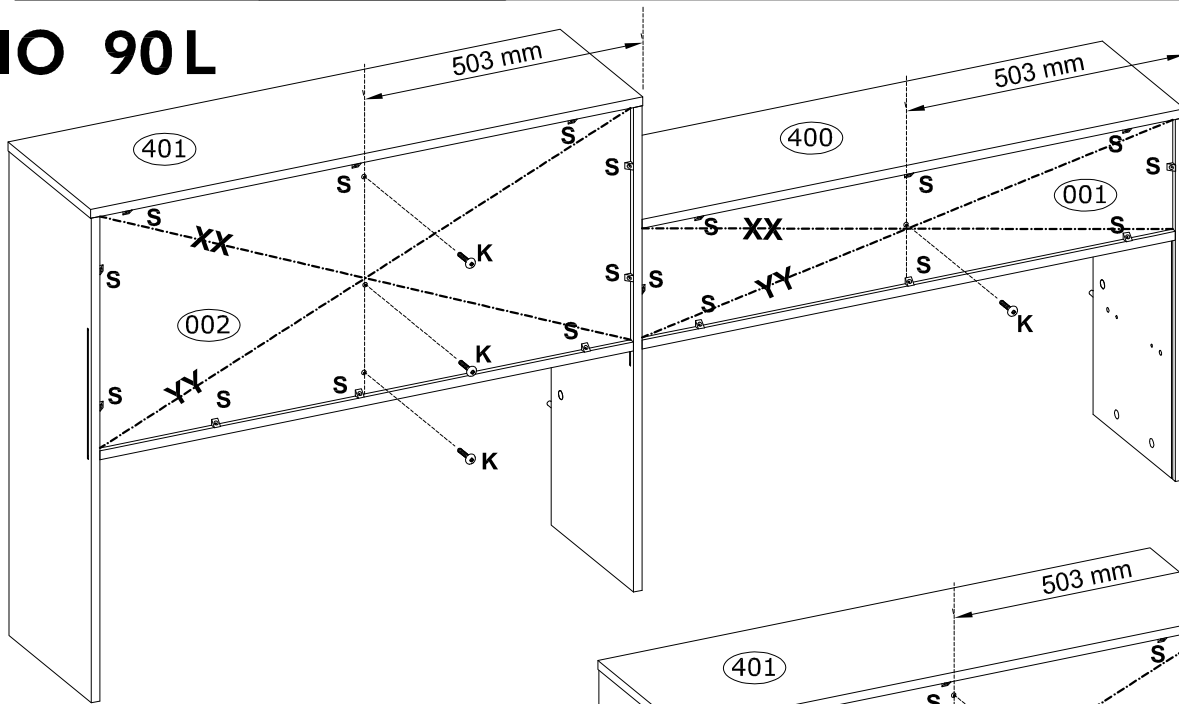

PINIO 90R

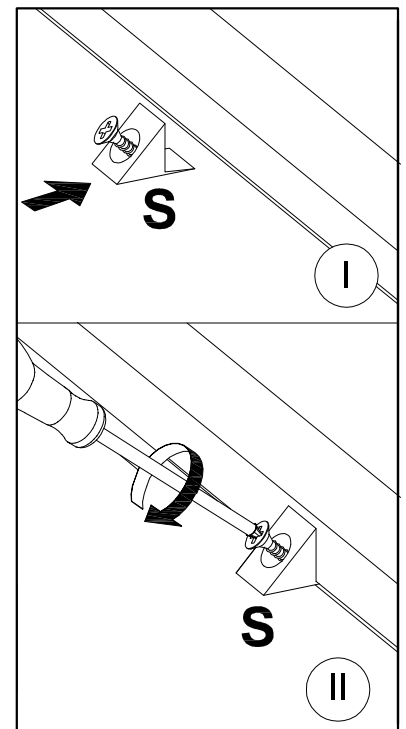
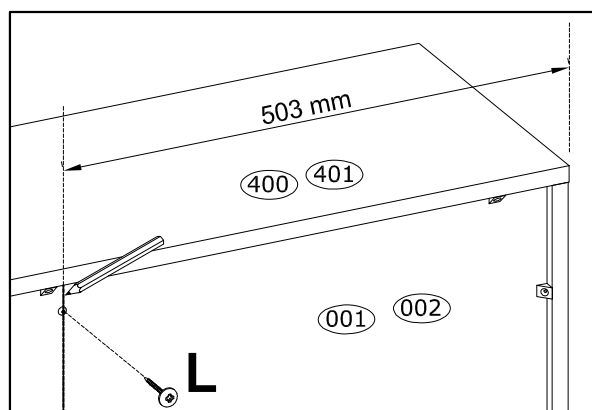
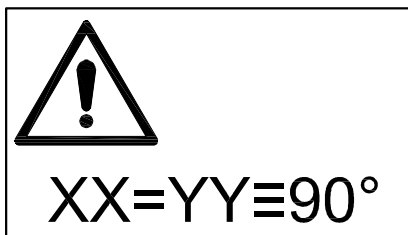
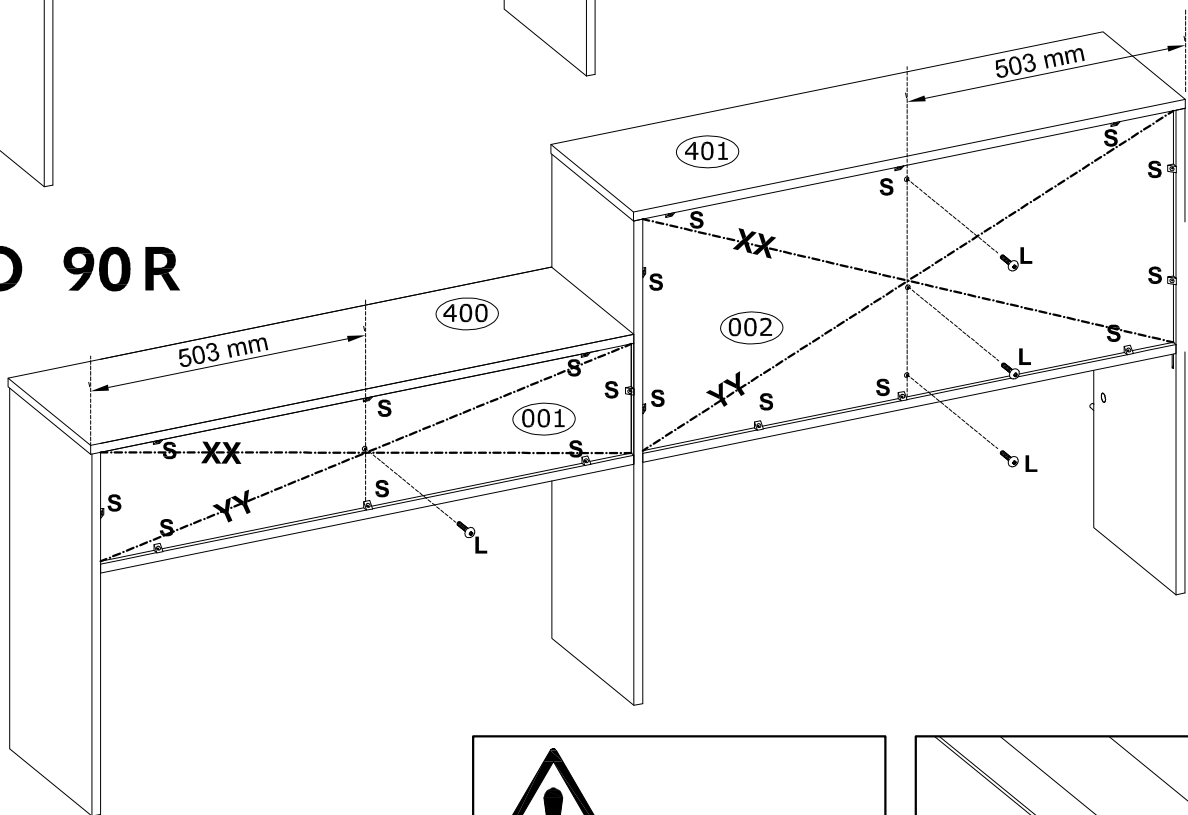

38

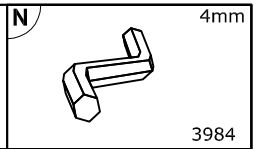
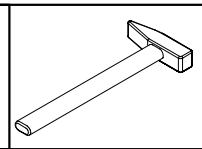
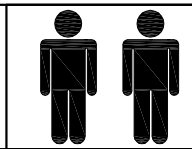
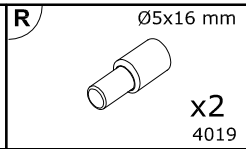
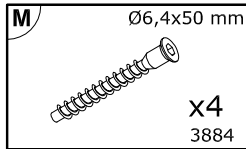

PINIO 90 L

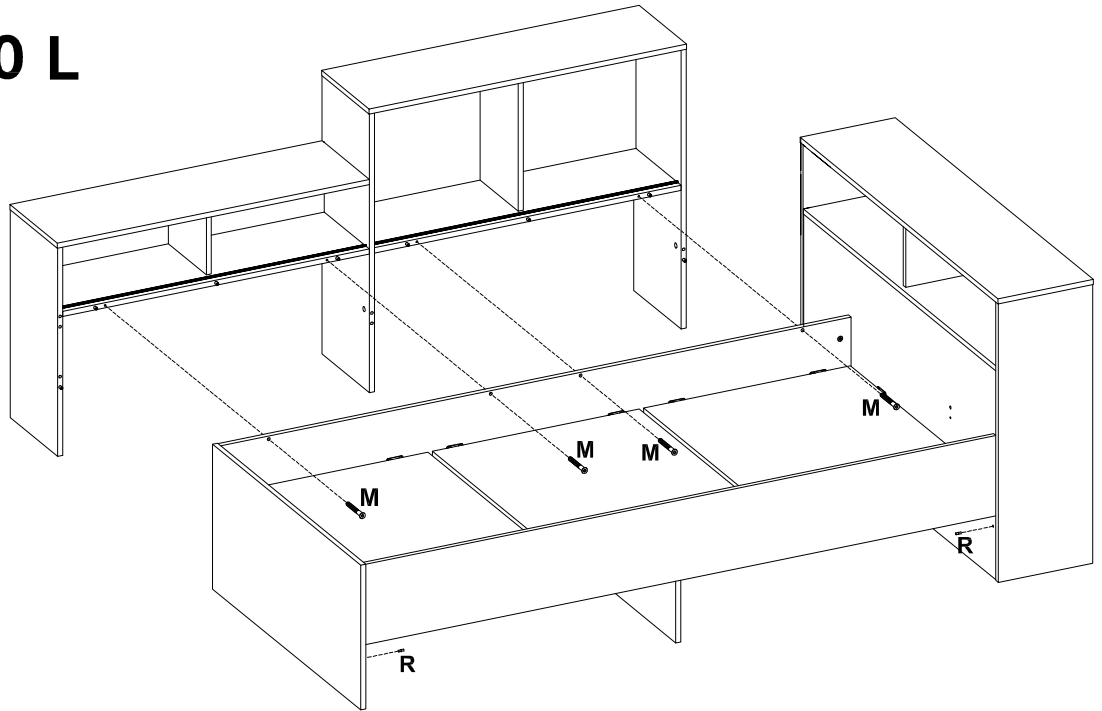

PINIO 90 R

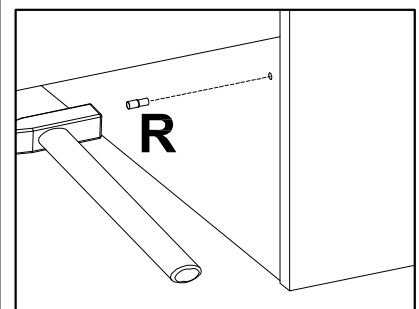
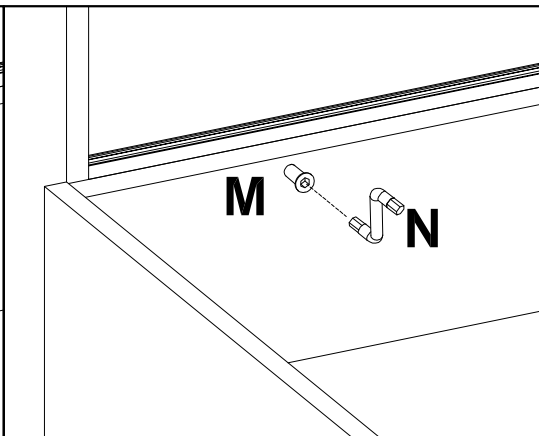
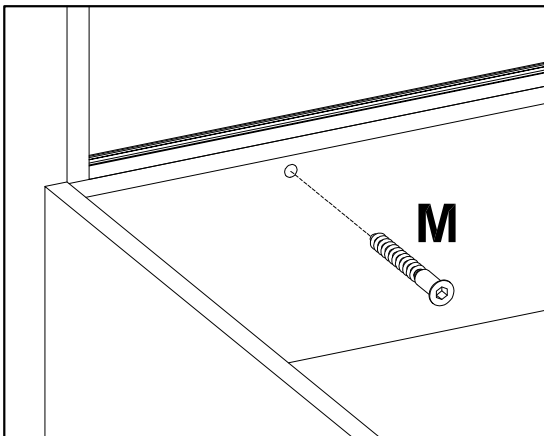
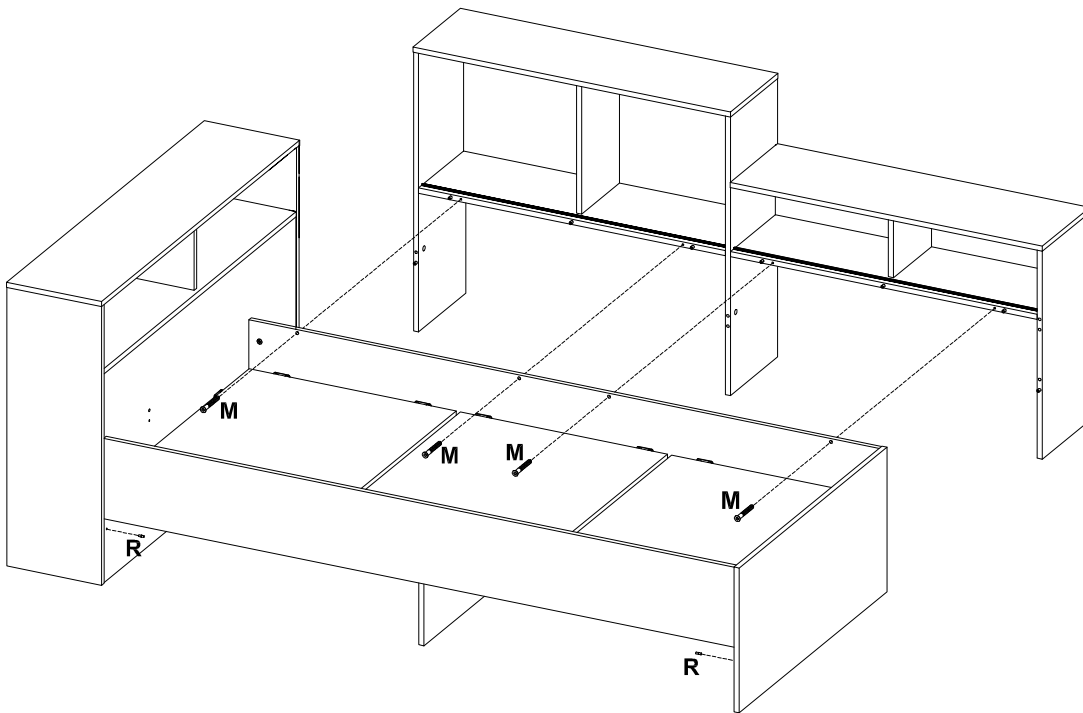

39

E
Ø15x12 mm
x2
3996

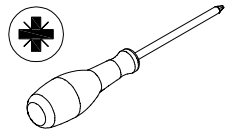

PINIO 90L

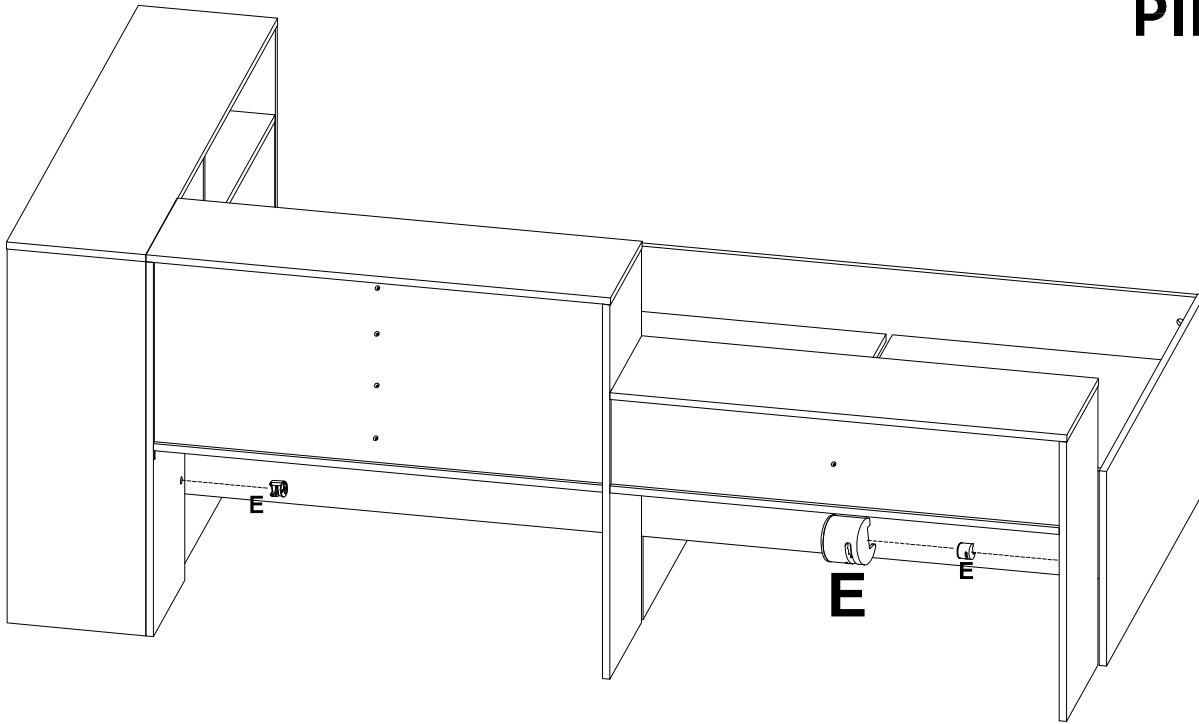

PINIO 90R

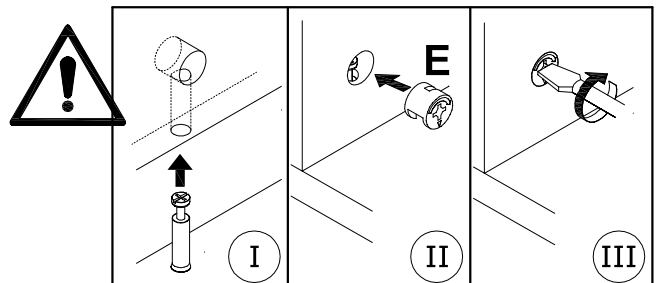
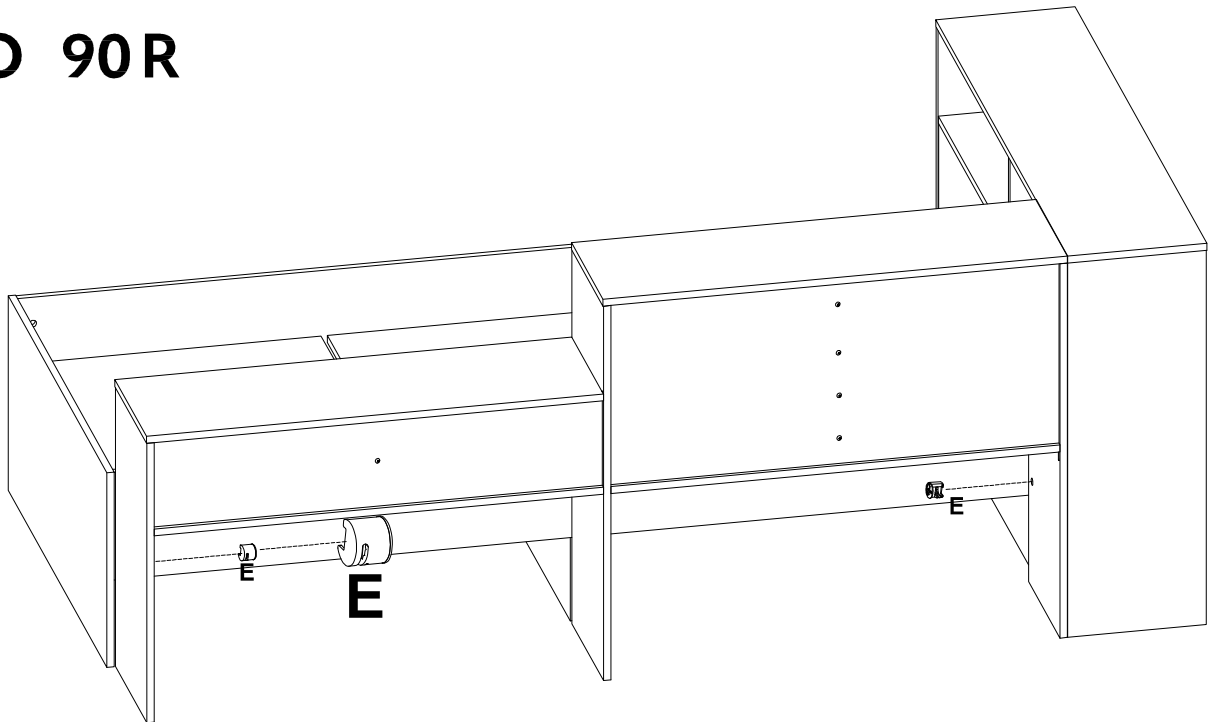

40

A Ø8x30 mm
x8
3989

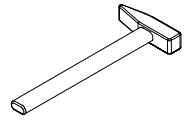
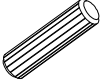

x2

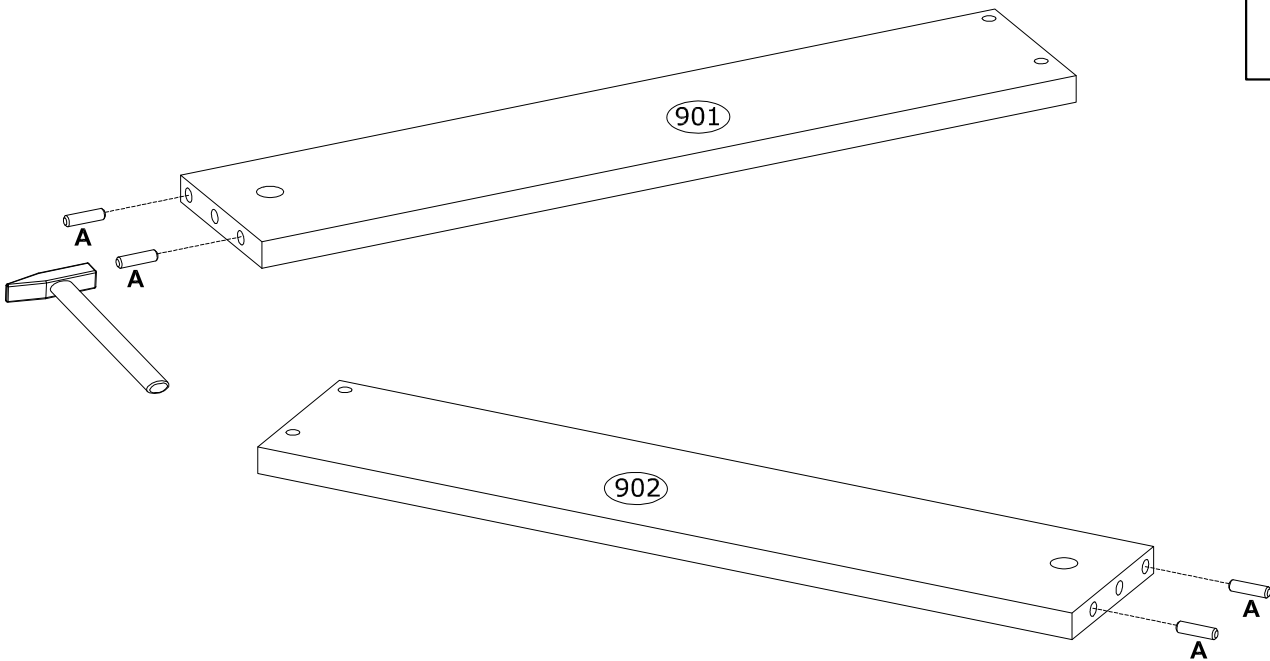

41

M Ø6,4x50 mm
x8
3884

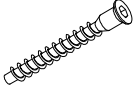

N 4mm
3984



x2

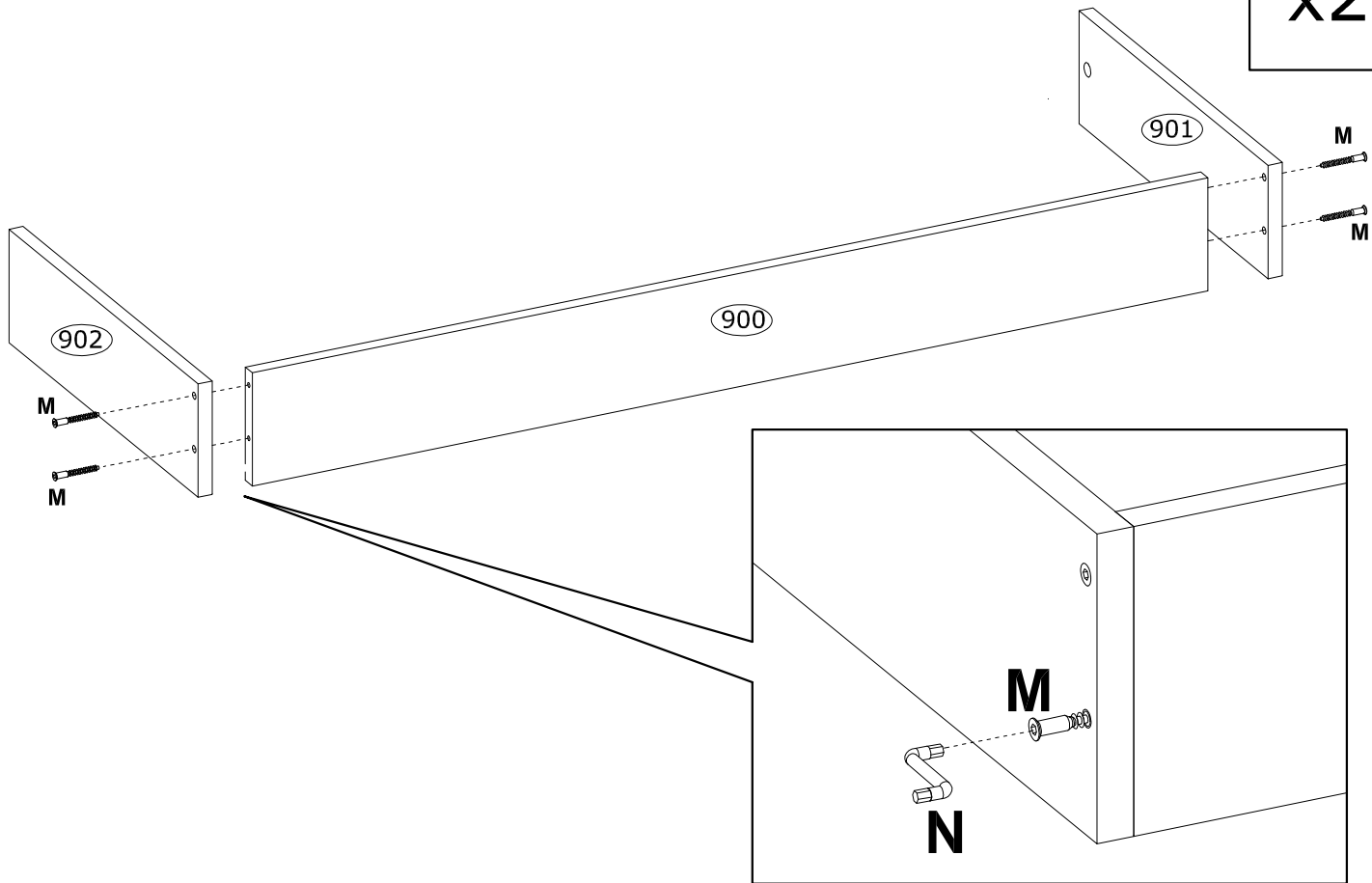

42

C
Ø6,5x36,5 mm
x4
4066

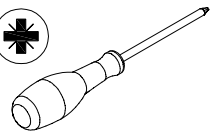

x2

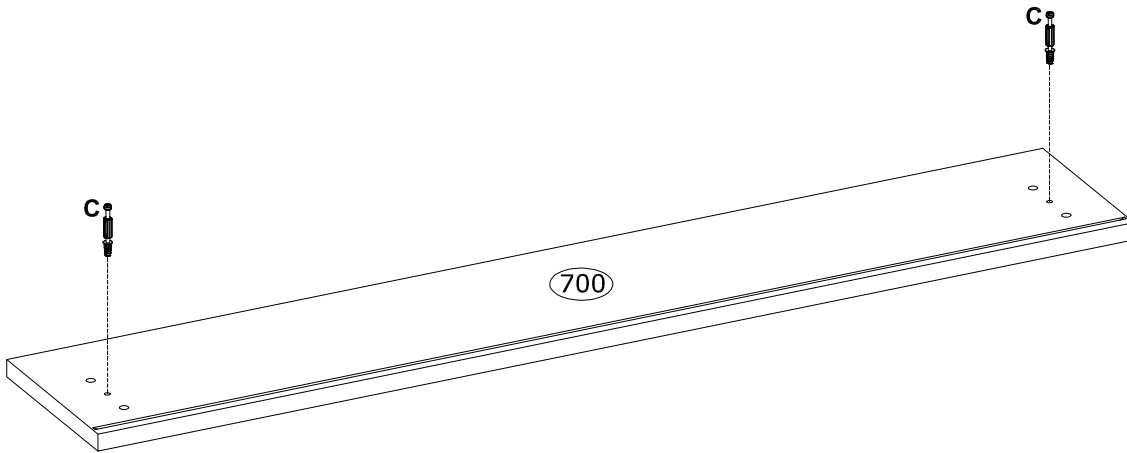

43

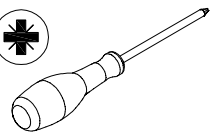

E
Ø15x12 mm
x4
3996

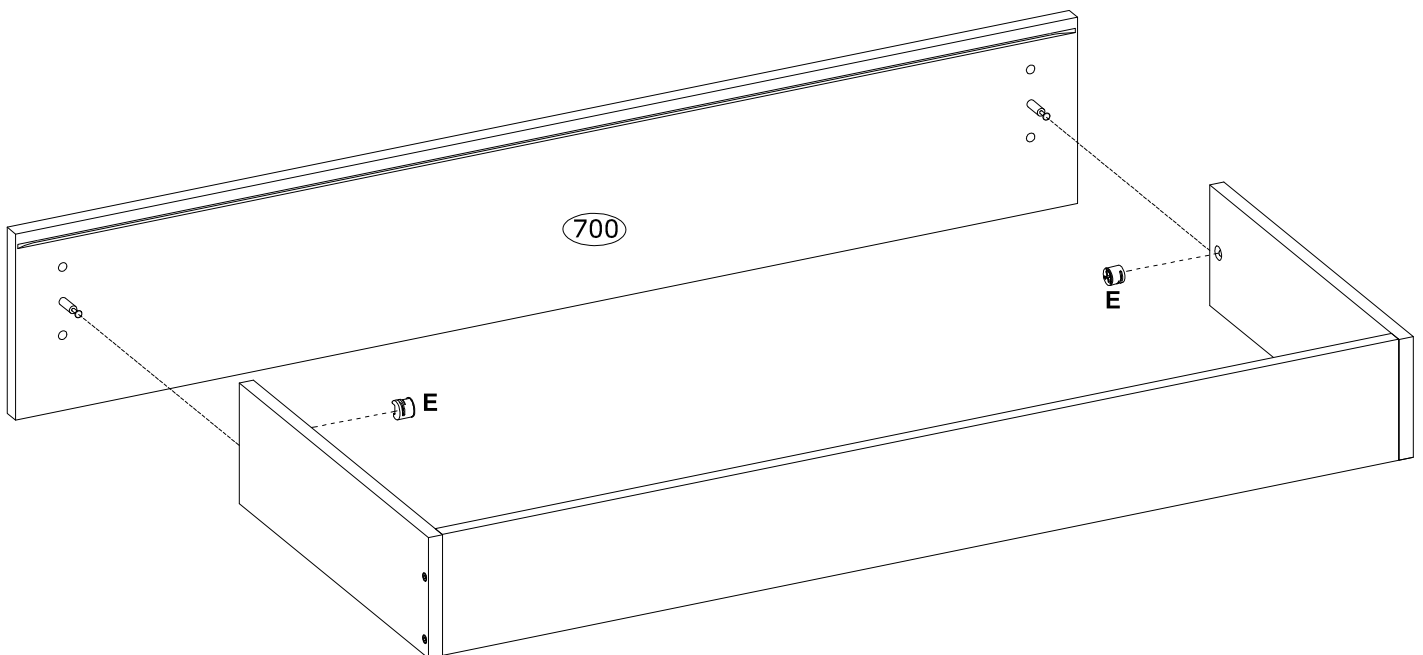

x2



44

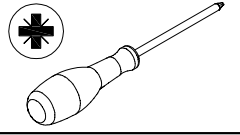

X  Ø 15 mm x8 3318	K  Ø3,0x25 mm x32 3887
---	--

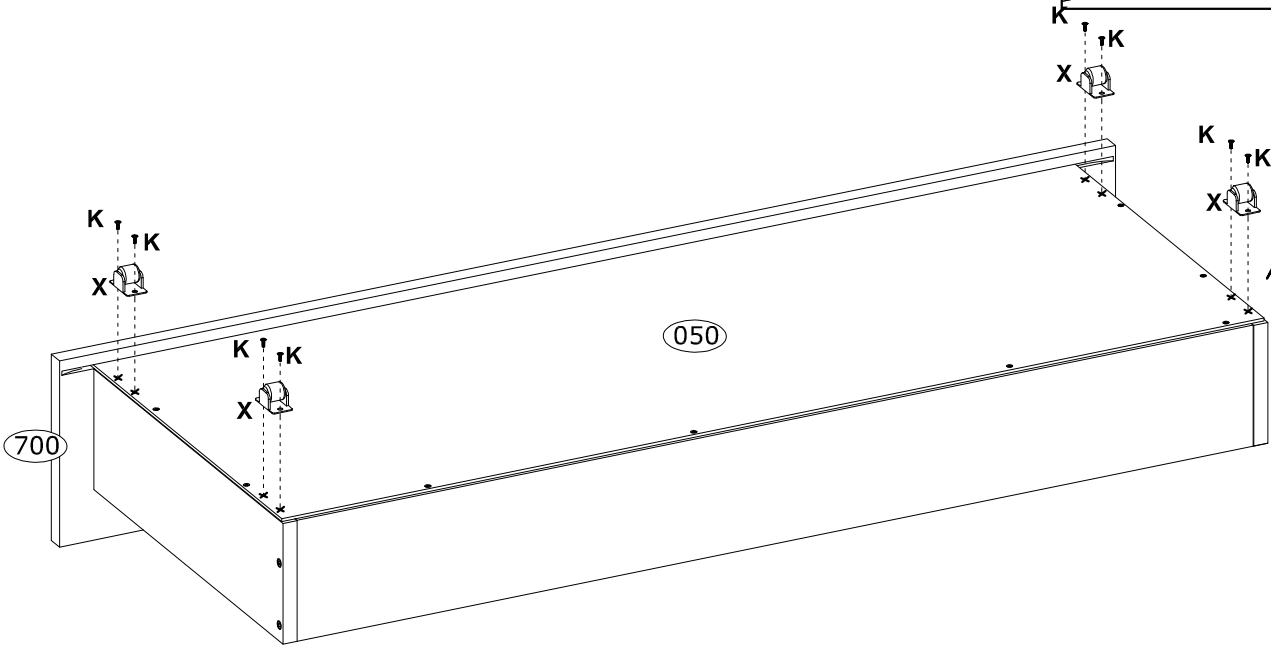
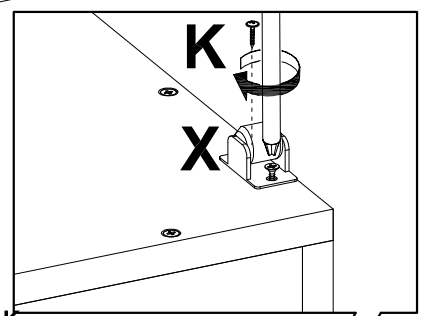
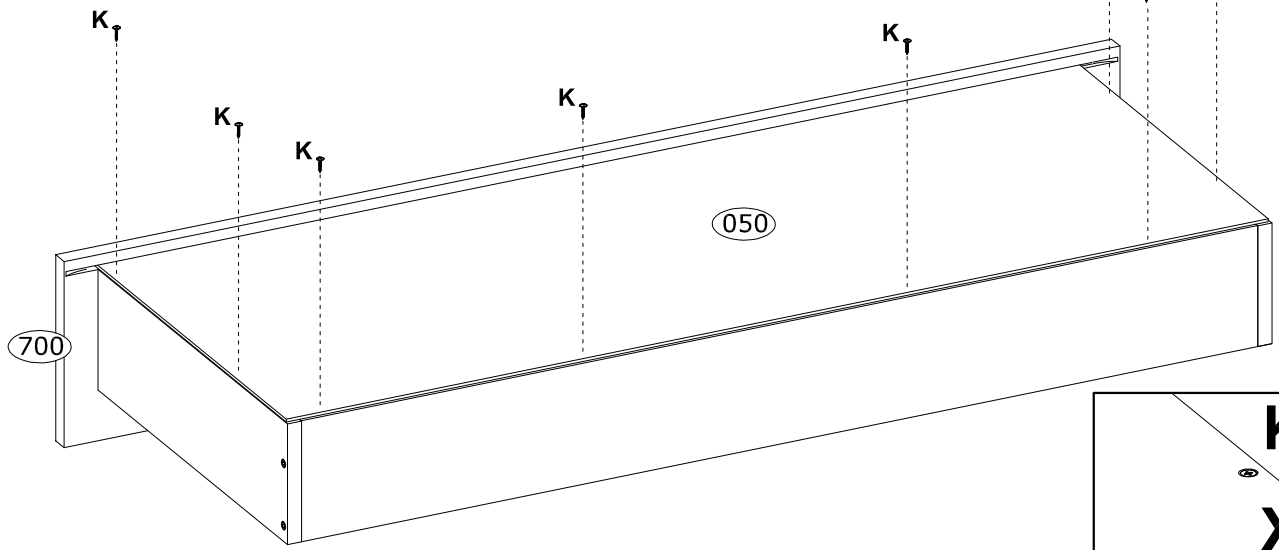
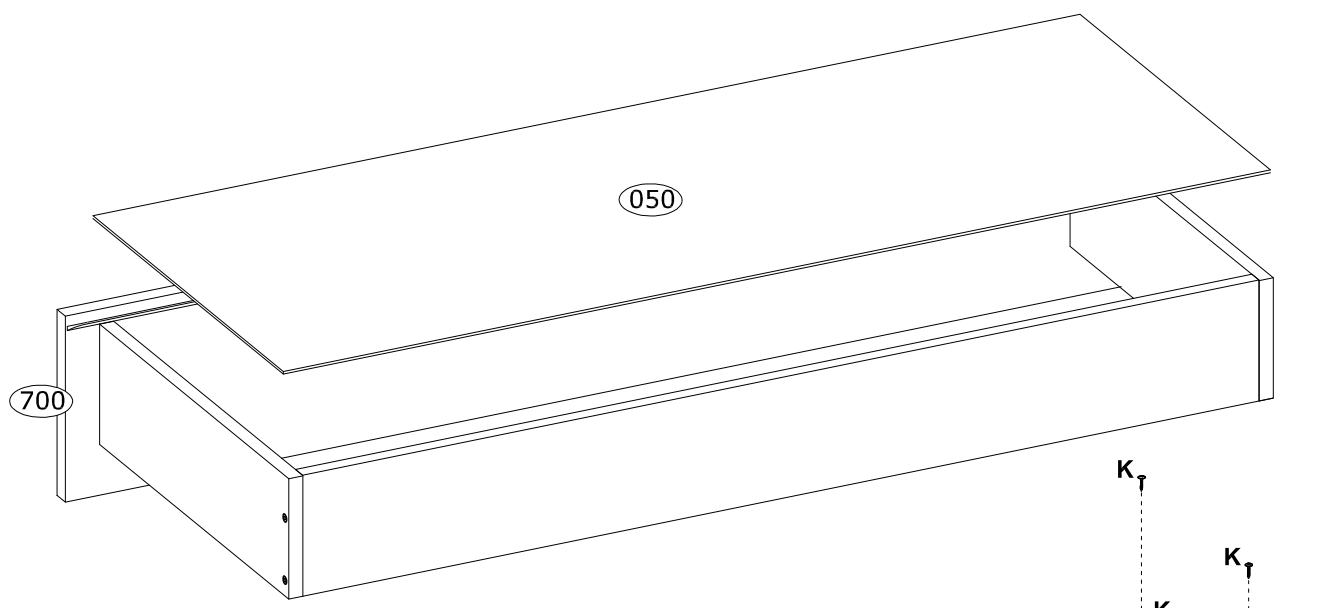

x2



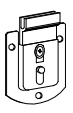
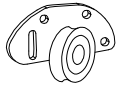

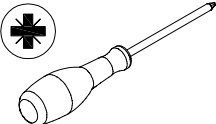
45

<p>W</p>  <p>x2 IN01006</p>	<p>U</p>  <p>x2 IN01007</p>	<p>J Ø4,0x16 mm</p>  <p>x10 3923</p>	<p>V Ø40 mm</p>  <p>x1 247431</p>	
--	--	--	--	--

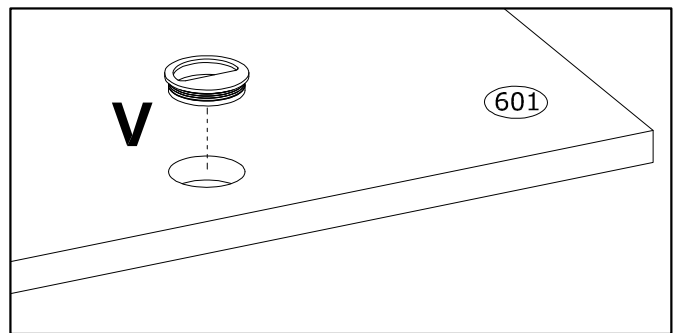
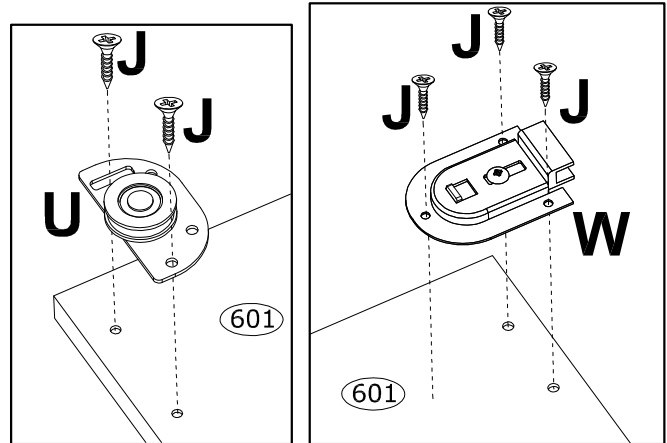
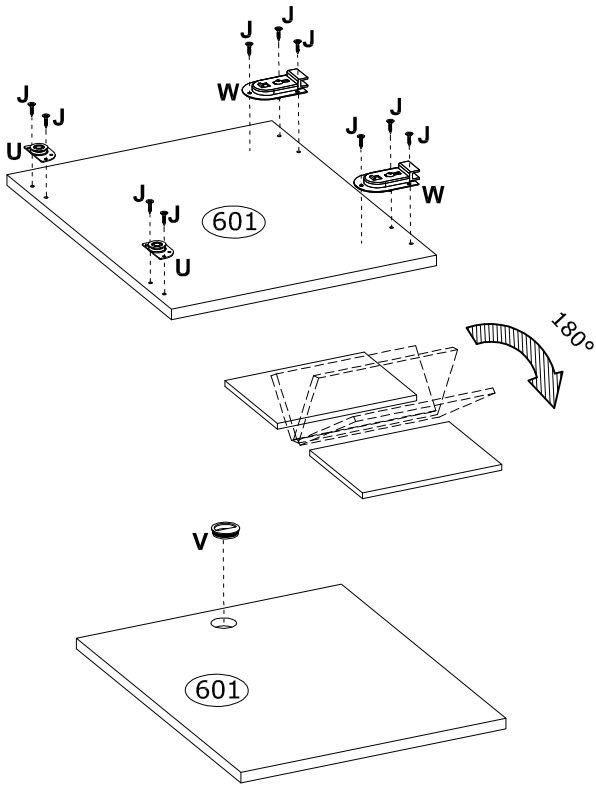
PINIO 90L | PINIO 90R

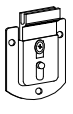
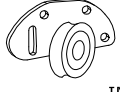

46

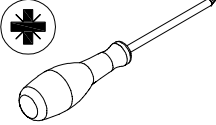
<p>W</p>  <p>x2 IN01006</p>	<p>U</p>  <p>x2 IN01007</p>	<p>J Ø4,0x16 mm</p>  <p>x10 3923</p>	<p>V Ø40 mm</p>  <p>x1 247431</p>	
---	---	--	---	---

PINIO 90L | PINIO 90R

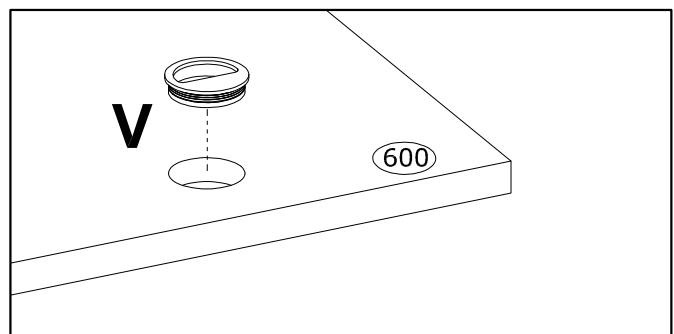
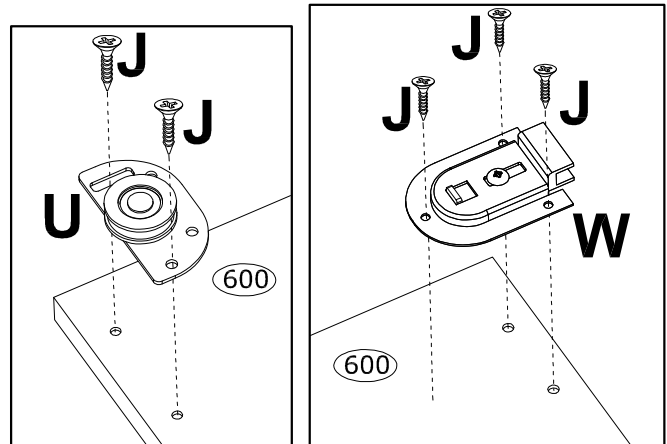
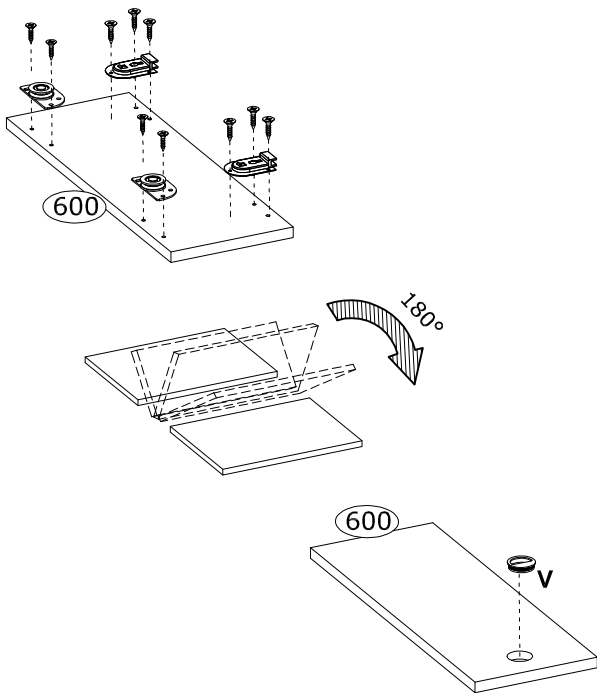

50

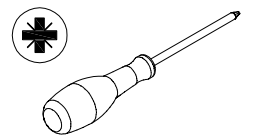

PINIO 90L | PINIO 90R

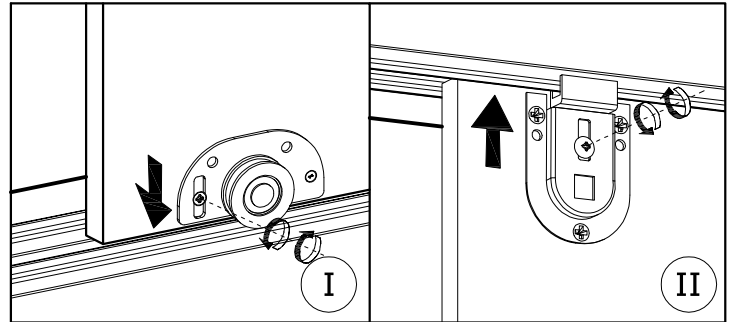
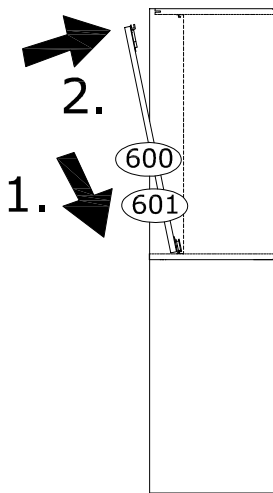



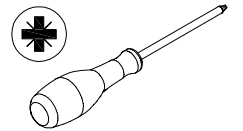
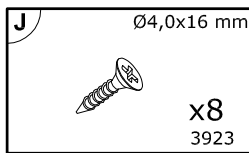

51

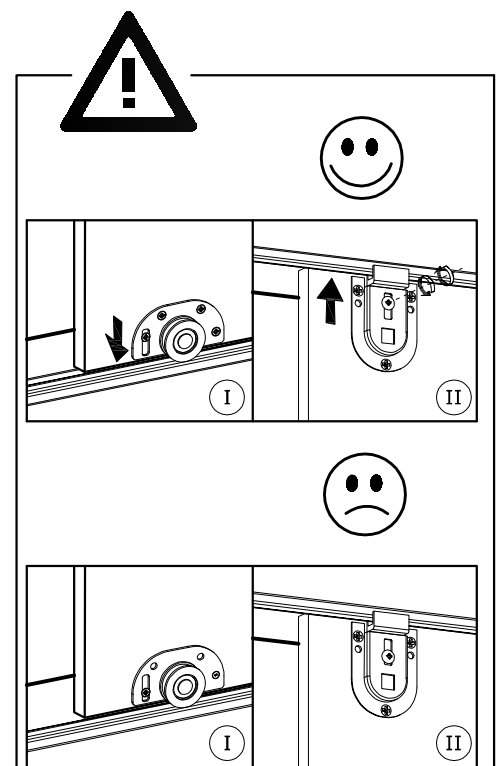
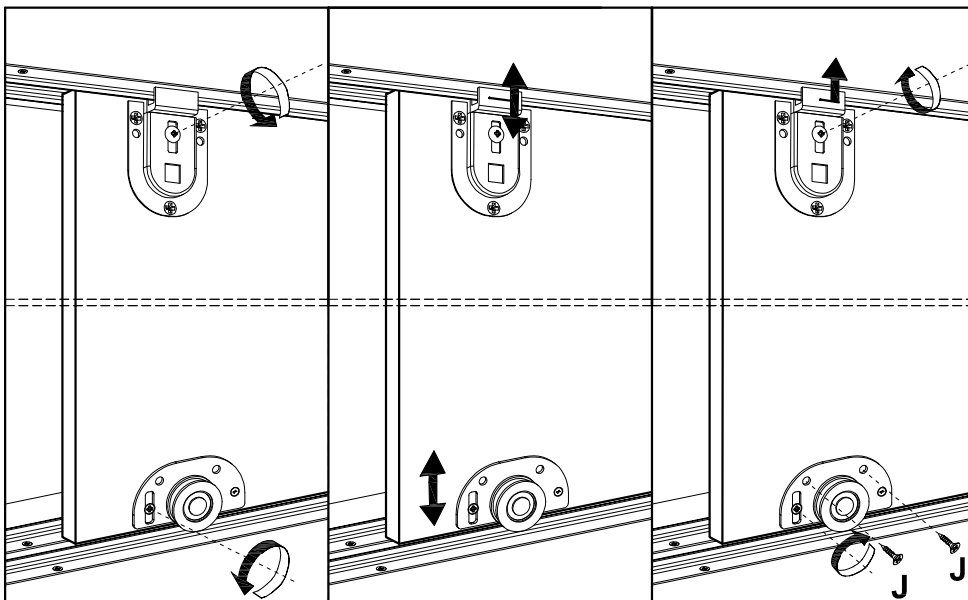
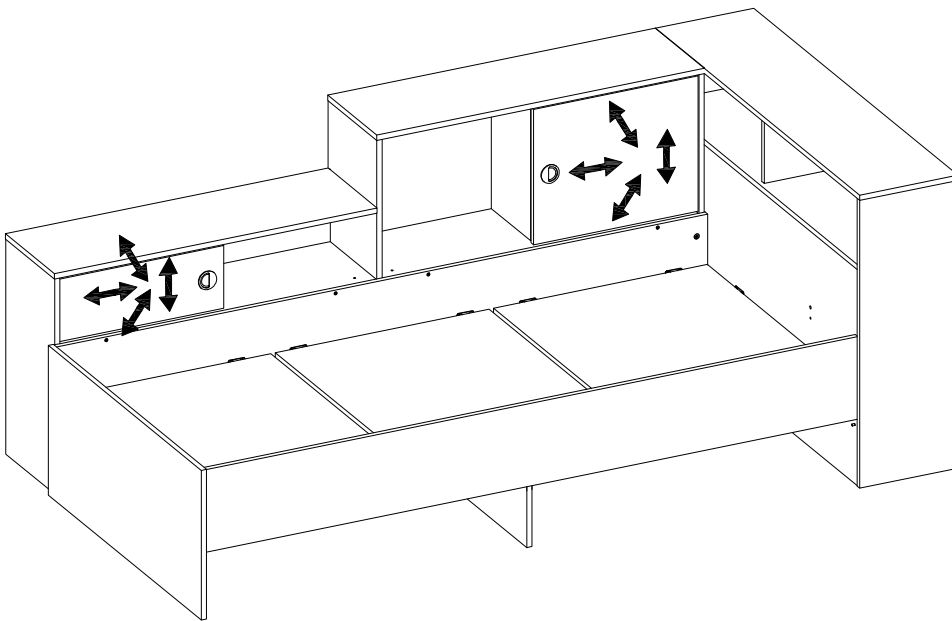

**PINIO 90L
PINIO 90R**



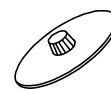

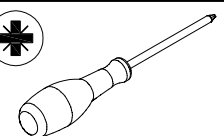

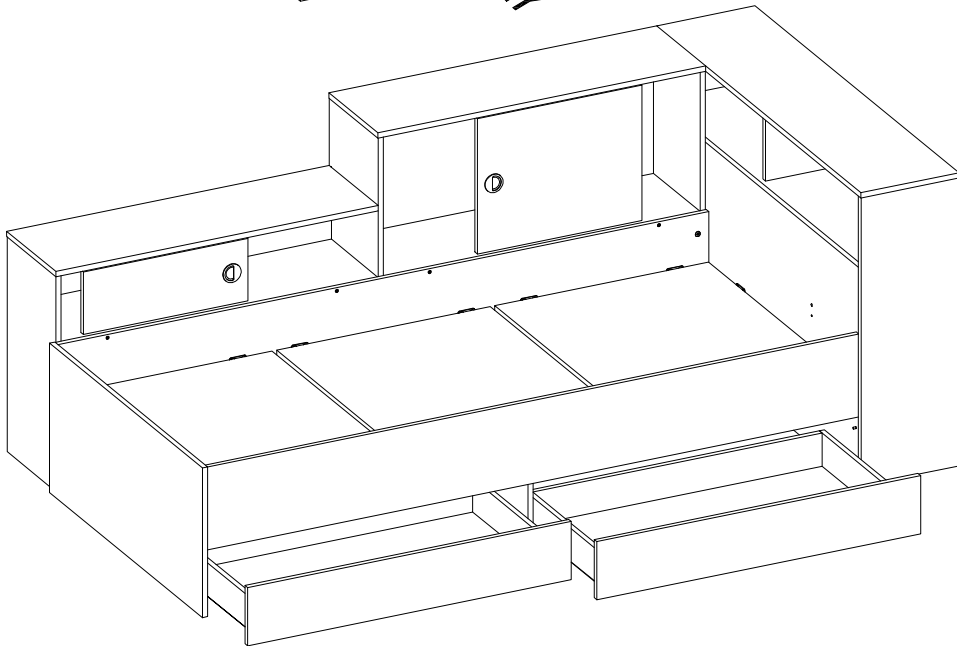
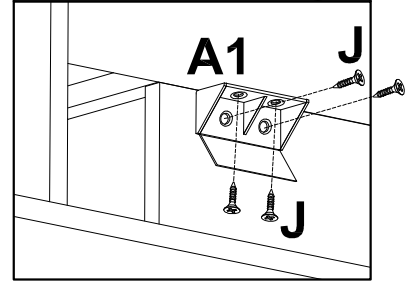
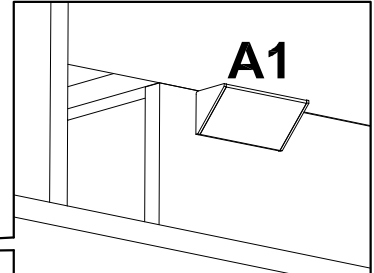
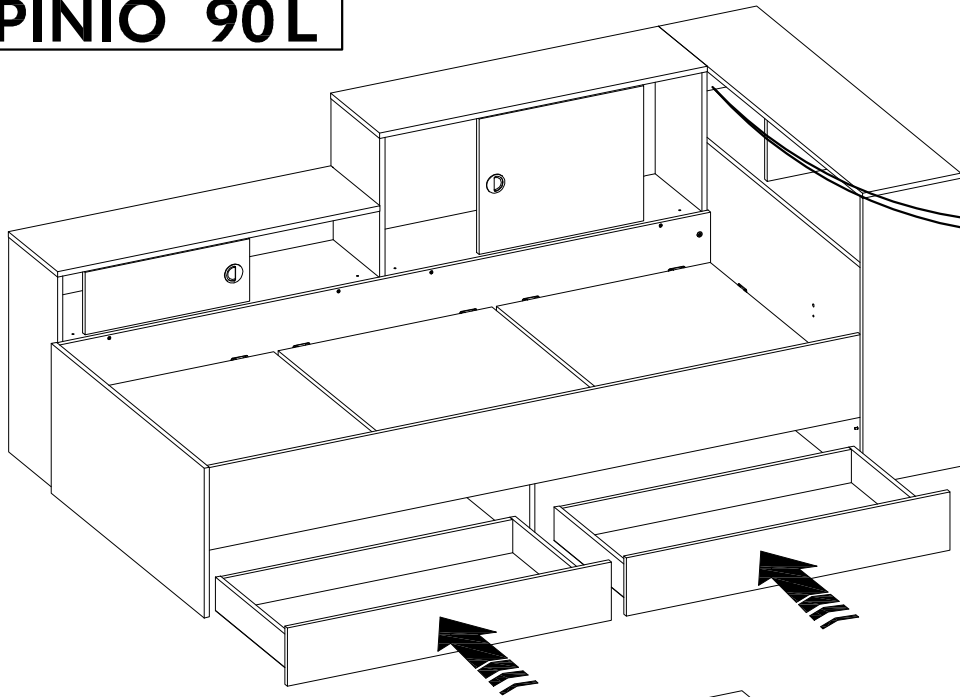

52

A1 43X21X21 mm  x1 228270	J Ø4,0x16 mm  x4 3923	F Ø15 mm  x28 136236	G Ø6,5 mm  x4 142727	 
--	--	---	--	--

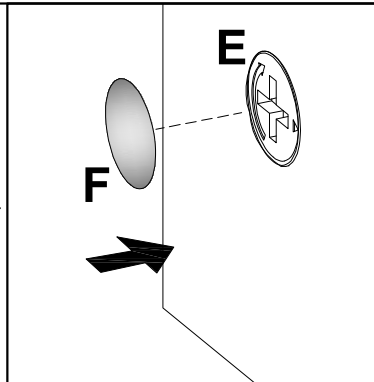
PINIO 90L

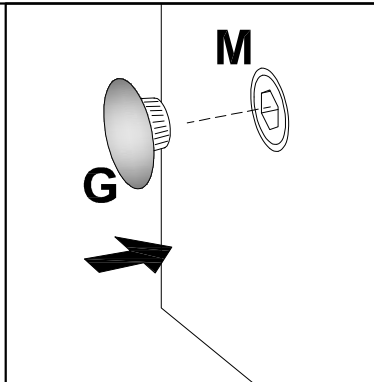

  	 E F	  	 M G
---	---	--	---

PINIO 90R

