

VILLA

LKZ 42416 / 75033

27

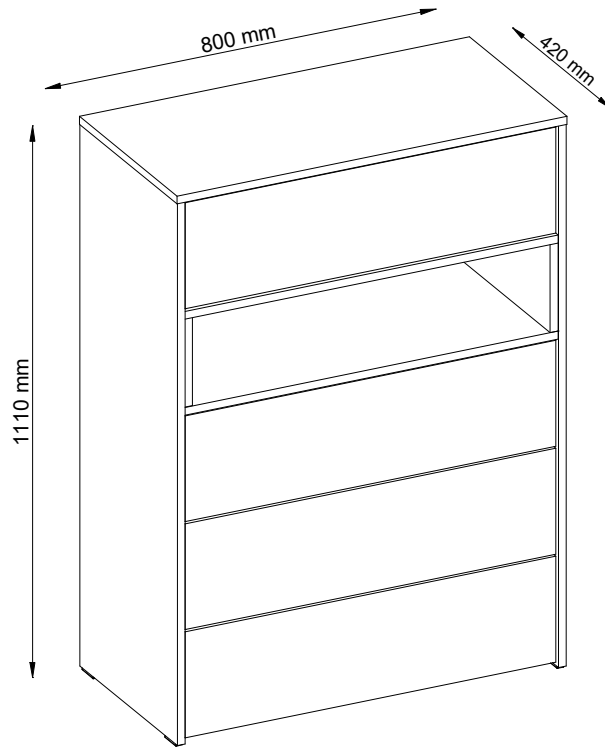

D

Montageanleitung
Nachtisch >Villa<

FR

Notice de montage
Table de nuit >Villa<

NL

Handleiding voor de montage
Nachtkastje >Villa<

CZ

Montážní návod
Noční stolek >Villa<

HU

Szerelési útmutató
Éjjeliszekrény >Villa<

TR

Montaj talinati
Komodin >Villa<

ES

Instrucciones de montaje
Mesilla de noche >Villa<

GB

Assembly instructions
Bedside table >Villa<

IT

Intruzioni di montaggio
Tavolino da notte >Villa<

PL

Instrukcja montażu
Stolik nocny >Villa<

SK

Návod na montáž
Nočný stolík >Villa<

RO

Instructiuni de montaj
Masă de noptieră >Villa<

RU

Инструкция по монтажу
Ночной столик >Villa<

PT

Instruções de montagem
Mesa de cabeceira >Villa<

SRB

Упутства за инсталацију
Сто поред кревета >Villa<

HR

Upute za instalaciju
Noćni ormarić >Villa<

SL

Návod na montaž
Nočna omarica >Villa<

LT

Surinkimo instrukcijos
Naktinis staliukas >Villa<

LV

Montāžas instrukcija
Naktsgaldiņš >Villa<

EE

Kokkupaneku juhised
Õölaud >Villa<

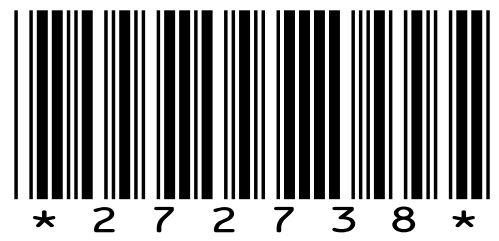
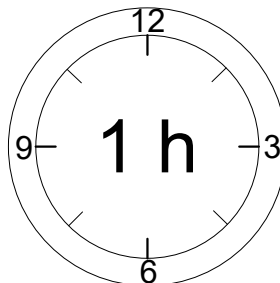
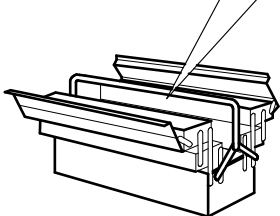
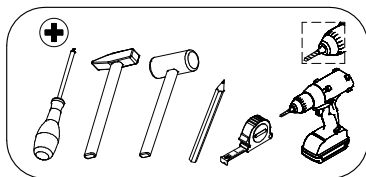
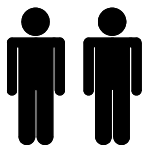

D-Ziehen Sie alle Schrauben sowie tragende Verbindungsteile nach ca. 5 Wochen nach, um einedauerhafte Standsicherheit zu gewährleisten.

GB-After approx. 5 weeks, tighten all screws and load-bearing connecting parts to ensure permanent stability.

FR-Resserrez toutes les vis ainsi que les pièces de fixation au bout d'environ 5 semaines pour garantir une sécurité de fixation durable.

IT- Ristringere tutte le viti e giunture dopo ca. 5 settimane, al fine di garantire una durevole solidità.

NL-Draai alle schroeven en ook dragende verbindingstukken na ca. 5 weken nog eens vast, zodateen continue stabiliteit wordt gegarandeerd.

PL-Prosimy po ok. 5 tygodniach dokręcić wszystkie śruby i elementy łączeniowe. Zagwarantuje to Państwu trwałość i stabilność połączeń.

CZ- Dotáhněte všechny šrouby a nosné spojovací díly přibližně po 5 týdnech, aby se zaručila trvalá stabilita.

SK-Po cca 5 týždňoch dotiahnite skrutky, aby bola zaručená ich trvalá stabilita.

HU-Húzza utána - kb. 5 hét múlva - az összes csavart és a teherhordó összekötő-alkatrészeket abiztonság érdekében.

RO-Pentru a asigura o stabilitate de durată, strângeți după cca. 5 săptămâni toate șuruburile, precumși toate elementele portante de legătură.

TR-Tüm vida ve taşıyıcı bağlantı parçalarını kalıcı bir duruş güvenliğini sağlamak için yaklaşık 5 haftasonra tekrar sıkınız.

RU - Подкрутите все болты, а также несущие соединительные детали припл. через 5 недель для обеспечения устойчивости в течение длительного времени.

SRB - Молим вас после акрокса. 5 недеља затегните све шрафове и причвршћиваче. То ће вам гарантовати трајност и стабилност веза.

HR - Molim vas, nakon cca. 5 tjedana zategnite sve vijke i pričvršćivače. To će vam jamčiti trajnost i stabilnost priključaka.

SL - Pýtame sa po cca. 5 týždňov utiahnite všetky skrutky a upevňovacie prvky. To zaručuje trvanlivosť a stabilitu spojov.

LT - Mes prašome po maždaug. 5 savaites priveržkite visus varžtus ir tvirtinimo detales. Taip užtikrinamas jungčių patvarumas ir stabilumas.

LV - Mēs lūdzam pēc apm. 5 nedēļas, pievelciet visas skrūves un stiprinājumus. Tas garantē savienojumu izturību un stabilitāti.

EE - Küsime pärast ca. 5 nädalat, pingutage kõiki kruvisid ja kinnitusi. See tagab ühenduste vastupidavuse ja stabiilsuse.

ES - Apriete todos los tornillos y elementos de conexión después de aprox. 5 semanas. Esto le garantizará la durabilidad y estabilidad de sus conexiones.

PT - Aperte todos os parafusos e elementos de ligação após aprox. 5 semanas. Isto garantirá a durabilidade e a estabilidade das suas ligações.

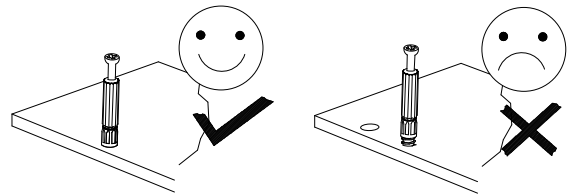

D Bitte nur mit einem Staubtuch oder leicht feuchtem Lappen reinigen. Keine scheuernden Putzmittel verwenden.

GB Please only clean with a duster or a damp cloth. Do not use any abrasive cleaners.

FR Veuillez nettoyer uniquement avec un chiffon à poussière ou un chiffon légèrement humide. N'avez pas utiliser de détergent abrasif.

IT Si raccomanda di pulire solo con un panno per la polvere o uno strofinaccio umido. Non utilizzare detersivi abrasivi.

NL Reinig alleen met een stofdoek of een lichtjes vochtige doek. Gebruik geen schurende poetsmiddelen.

PL Czyszczenie należy wykonać wyłącznie za pomocą ściereczki lub lekko nawilżonego ręcznika. Nie stosować środków czyszczących do szorowania.

CZ Čistěte prosím jen prachovkou nebo lehce navlhčeným hadrem. Nepoužívejte drhňoucí čisticí prostředky.

SK Na čistenie používajte len prachovku alebo zľahka navlhčenú utierku. Nepoužívajte žiadne drhňúce čistiace prostriedky.

HU Kérjük, csak portórló kendővel vagy enyhén nedves ronggyal tisztítsa. Ne használjon dörzshatású tisztítószeret.

RO Vă rugăm să utilizați la curățare exclusiv o cârpă de șters praful sau o cârpă ușor umezită. Nu utilizați substanțe de curățat abrazive.

TR Lütfen sadece bir toz bezikle veya hafif nemli yumuşak bir bezle siliniz. Aşındırıcı temizlik malze-meleri kullanmayınız.

RU Для чистки используйте, пожалуйста, тряпку для пыли или слегка влажную ветошь. Неиспользовать абразивные чистящие средства.

SBR Чишћење треба обавити само крпом или благо влажним пешкиром. Немојте користити средство за чишћење рибања.

HR Čišćenje treba obaviti samo krpom ili blago navlaženim ručnikom. Ne koristite sredstva za čišćenje ribanja.

SL Čistenie by sa malo vykonávať len handričkou alebo ľahko navlhčeným uterákom. Nepoužívajte čistiace prostriedky na drhnutie.

LT Valyti galima tik šluoste arba lengvai sudrėkintu rankšluosčiu. Nenaudokite šveičiamųjų valiklių.

LV Tīršana jāveic tikai ar drānu vai viegli samitrinātu dvieli. Neizmantojiet tīršanas līdzekļus.

EE Puhastada tohib ainult lapiga või kergelt niisutatud rätikuga. Ärge kasutage puhastusvahendeid.

PT A limpeza deve ser feita apenas com um pano ou toalha ligeiramente húmida. Não utilize produtos de limpeza abrasivos.

ES La limpieza debe realizarse únicamente con un paño o toalla ligeramente húmedo. No utilice agentes de limpieza abrasivos.

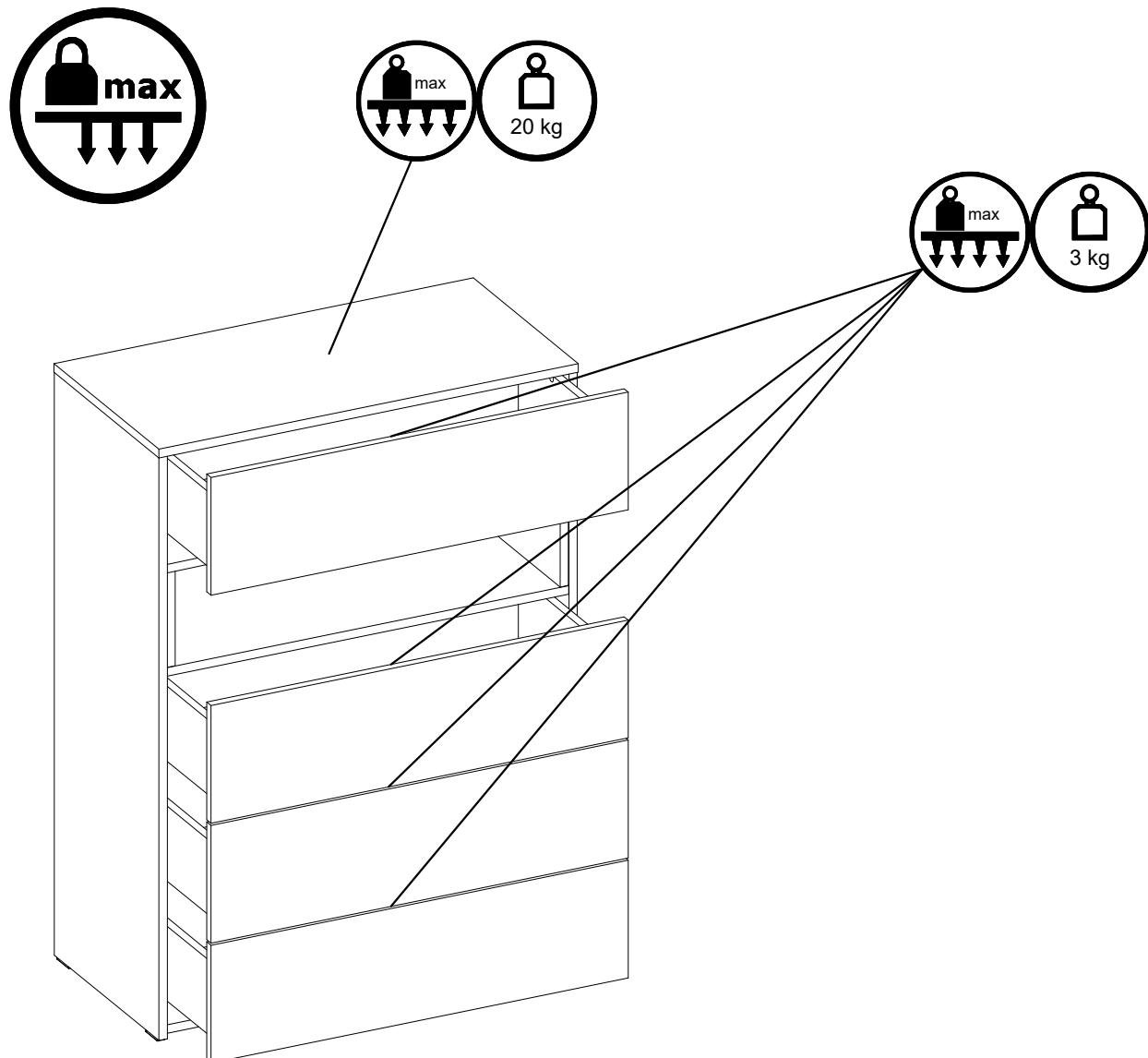
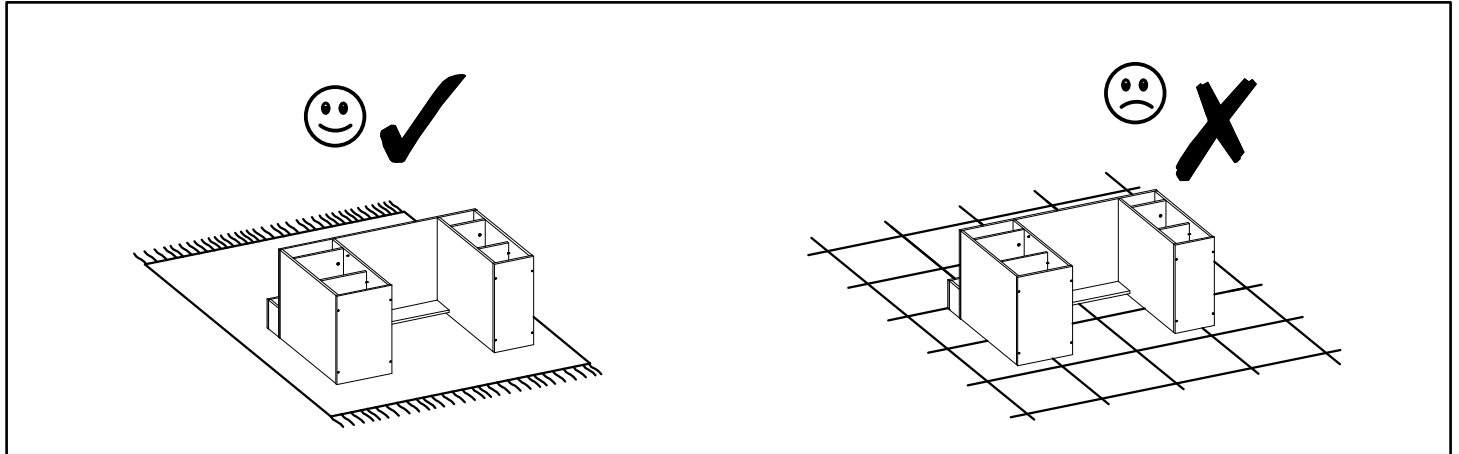
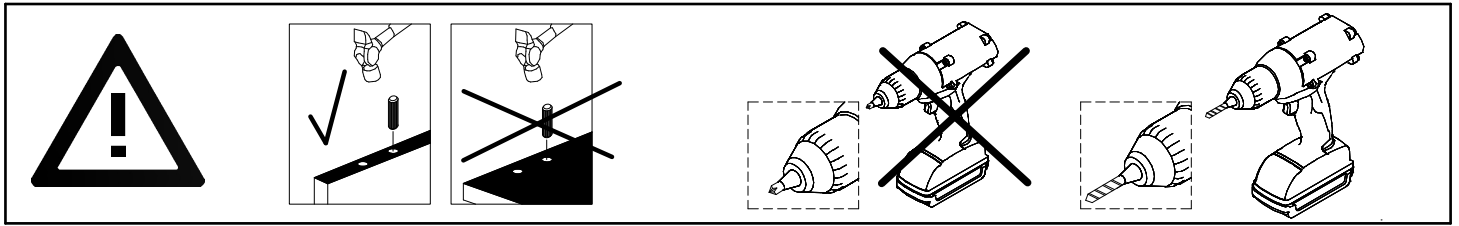
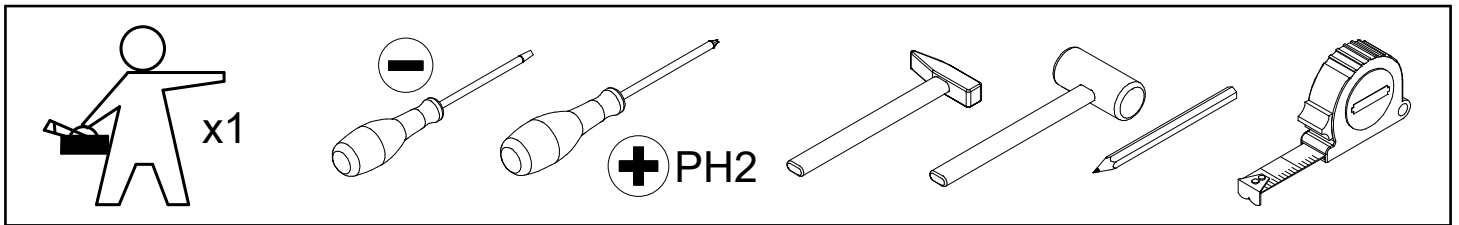

Service · Assistenza · Dienstverlening · Serwis Servis · Szerviz · Сервисная служба · Сервис · Serwis · Servis

Name · Nom · Nome · Naam ·
Nazwa · Jméno · Názov · Név ·
Denumire · Isim · Название

VILLA

Typ · Type · Tip · Típus · Típo ·
Тип

27

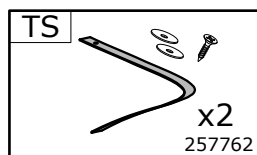
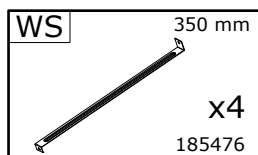
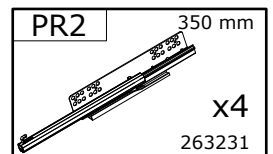
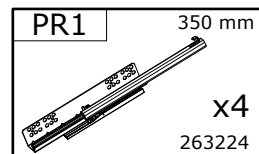
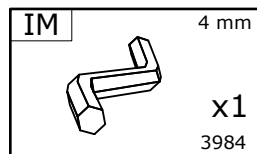
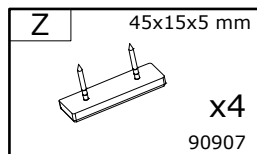
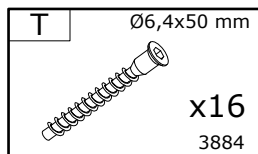
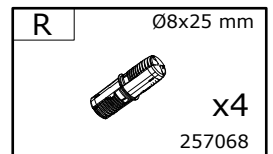
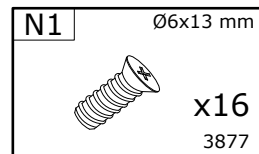
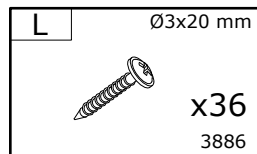
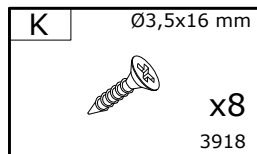
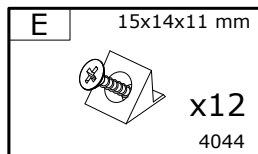
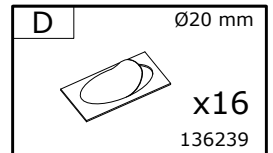
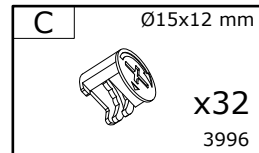
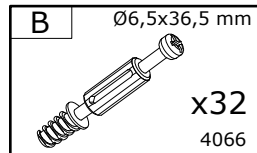
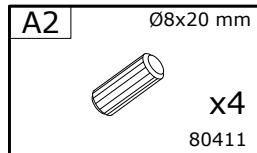
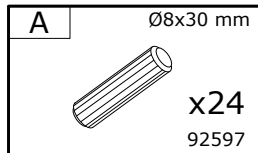
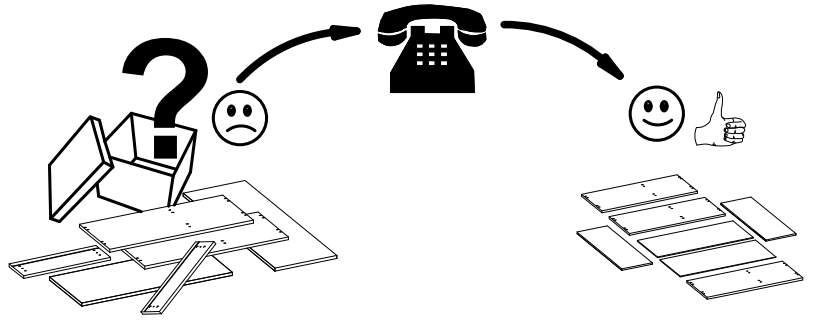
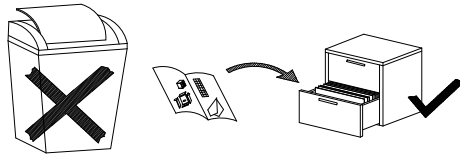

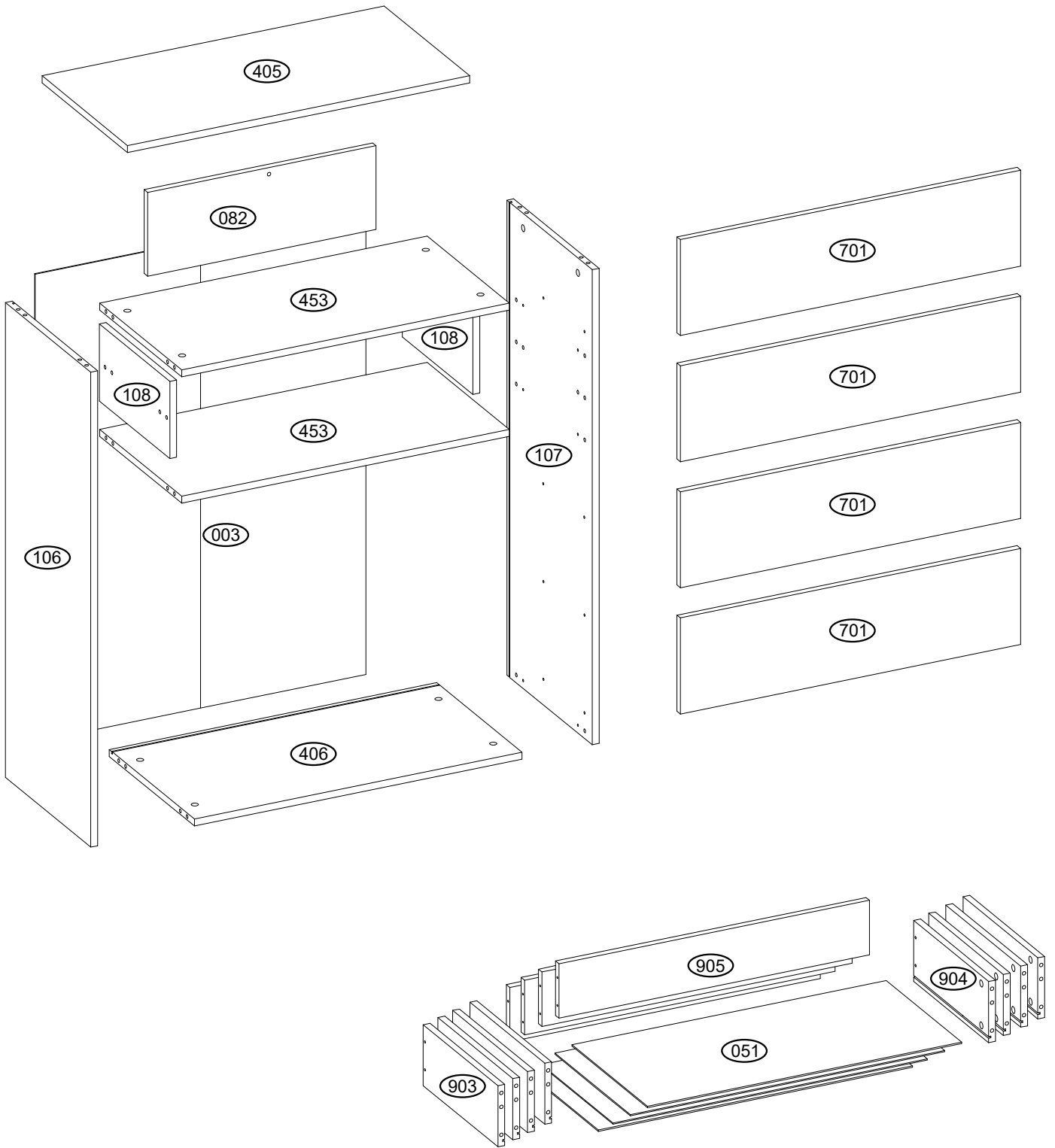

1

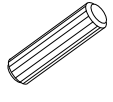
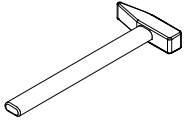
A	Ø8x30 mm		x4 92597	
---	----------	--	-------------	--

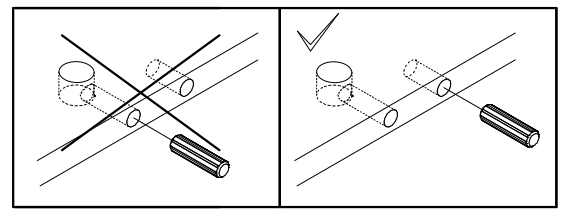
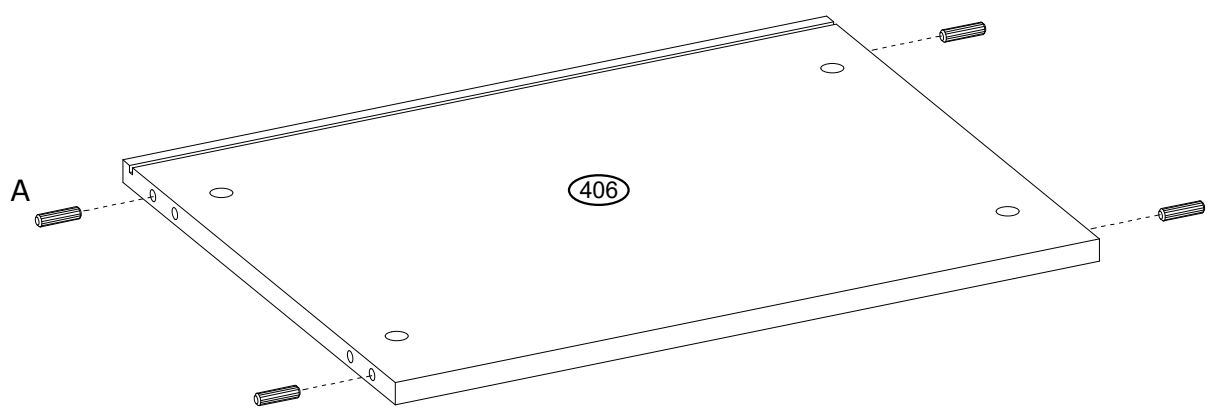

2

A	Ø8x30 mm		x8 92597	
---	----------	---	-------------	---

x2

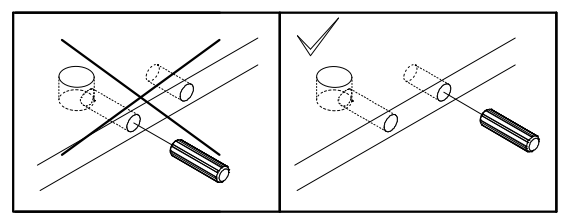
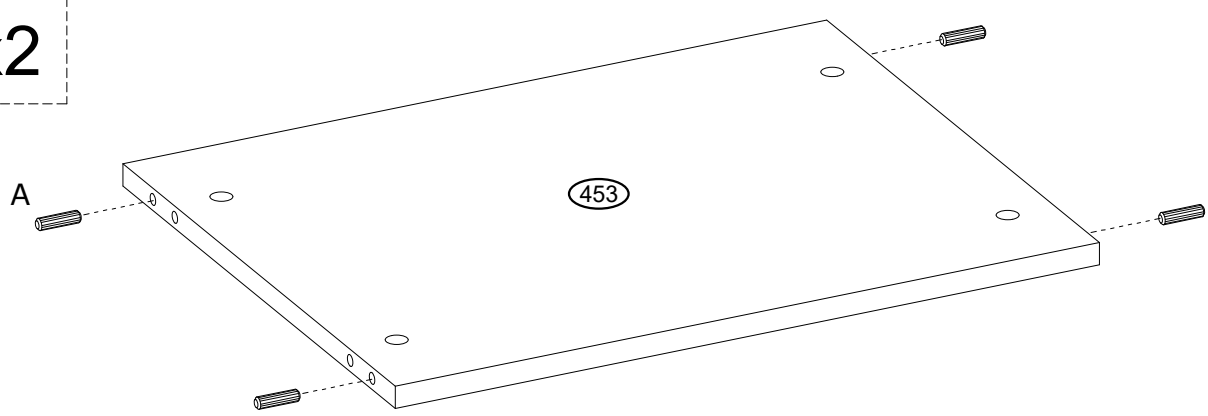

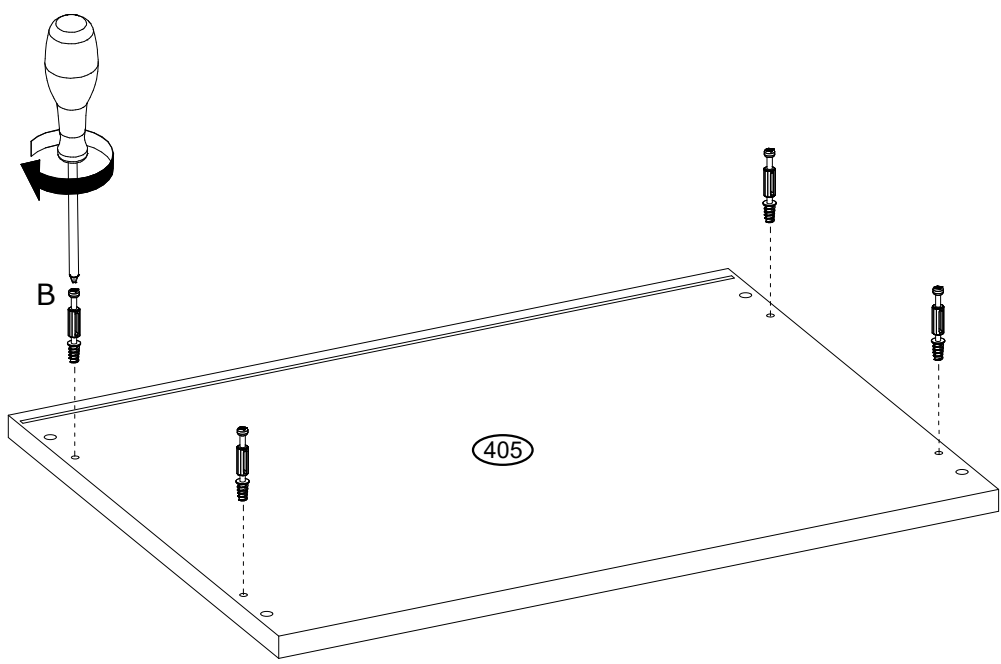

3

<p>B $\varnothing 6,5 \times 36,5$ mm</p>  <p>x4 4066</p>		
--	--	--



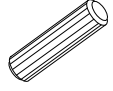
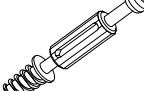

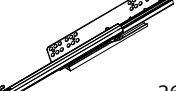
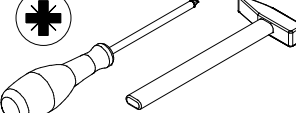
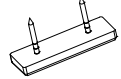

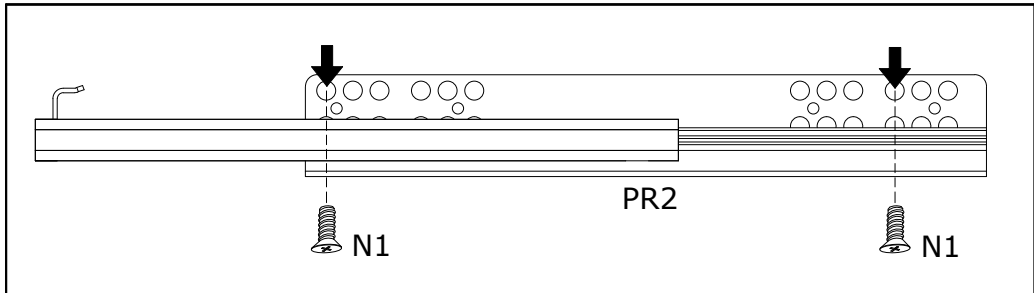
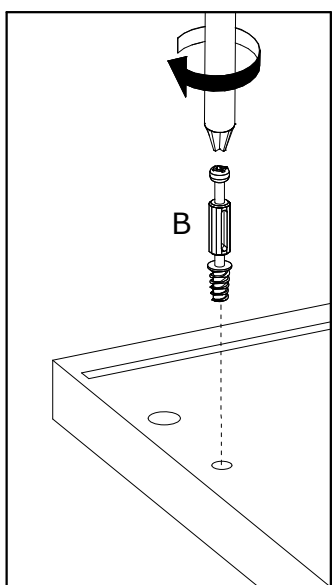
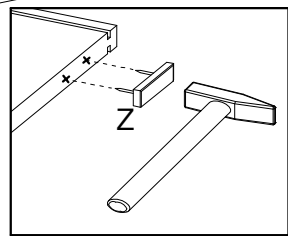
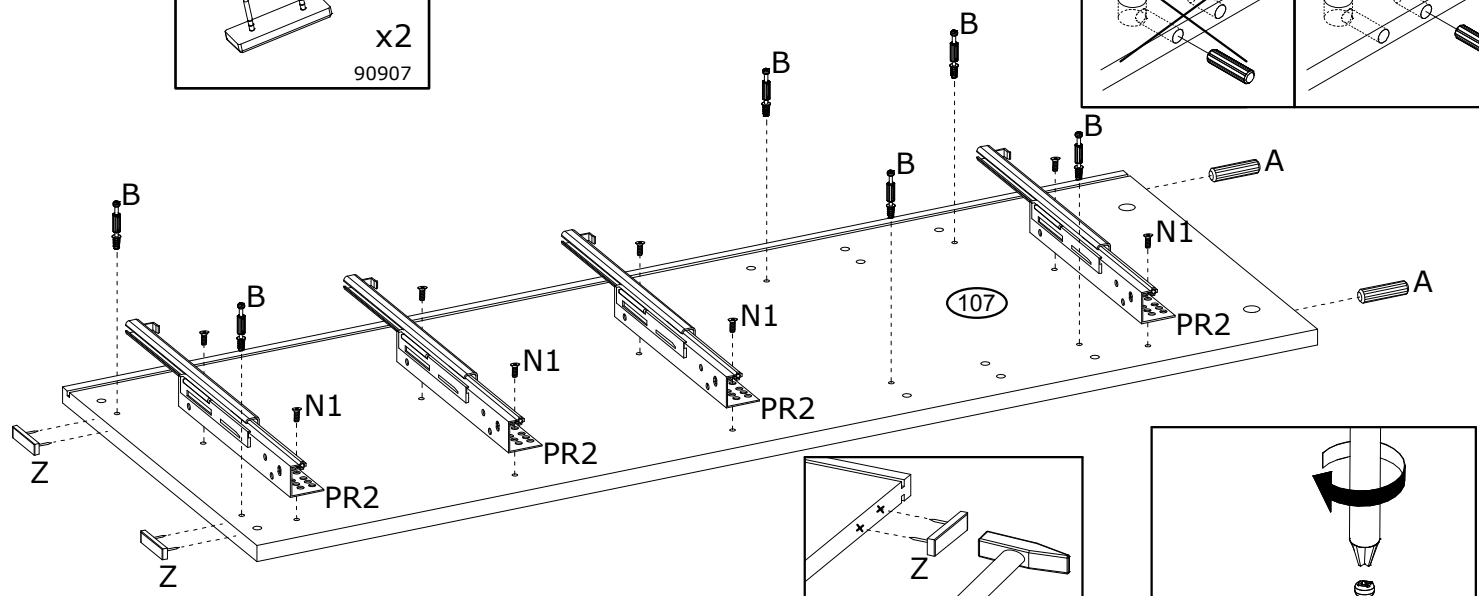
4

<p>A $\varnothing 8 \times 30$ mm</p>  <p>x2 92597</p>	<p>B $\varnothing 6,5 \times 36,5$ mm</p>  <p>x6 4066</p>	<p>N1 $\varnothing 6 \times 13$ mm</p>  <p>x8 3877</p>	<p>PR2 350 mm</p>  <p>x4 263231</p>	
<p>Z 45x15x5 mm</p>  <p>x2 90907</p>				

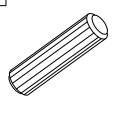
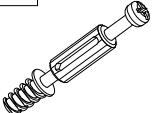

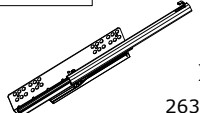
5

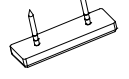
A Ø8x30 mm  x2 92597	B Ø6,5x36,5 mm  x6 4066	N1 Ø6x13 mm  x8 3877	PR1 350 mm  x4 263224	
Z 45x15x5 mm  x2 90907				

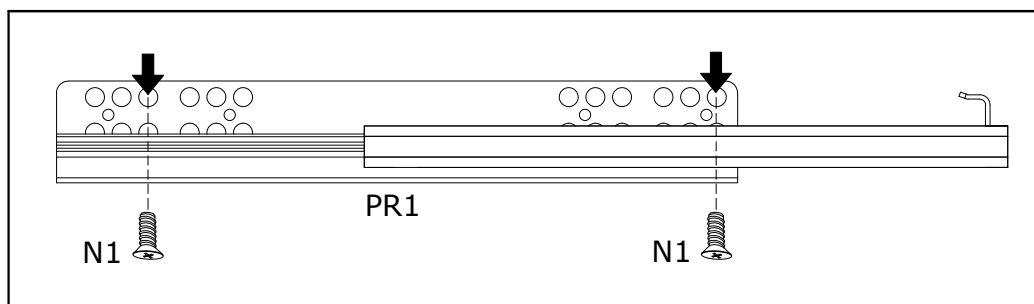
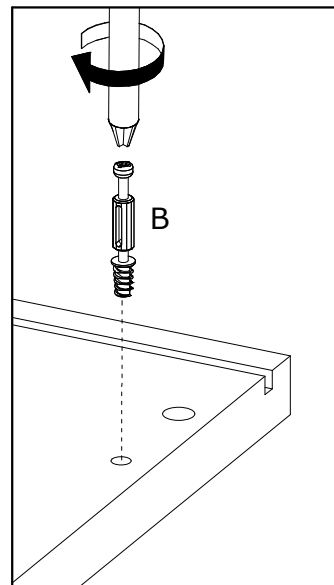
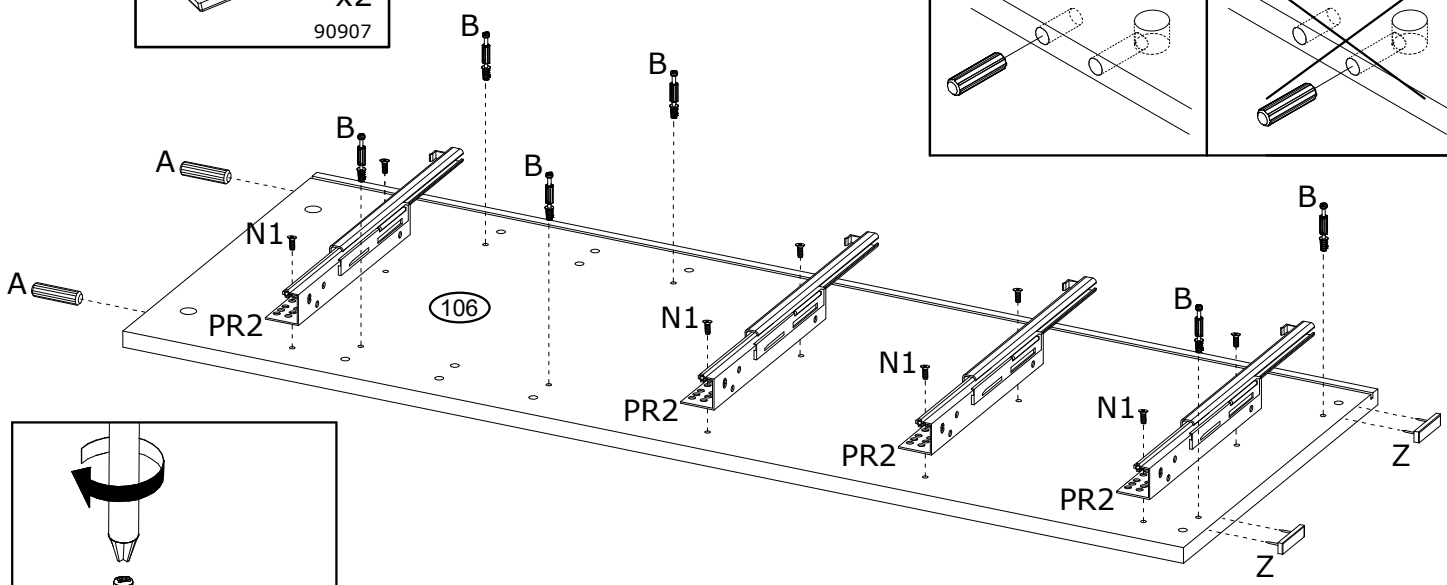
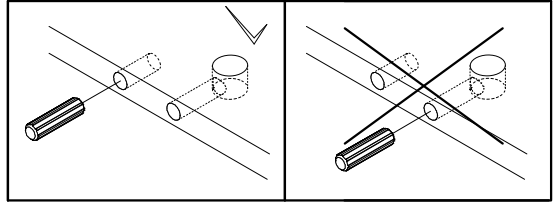



6

A2 Ø8x20 mm  x4 80411	R Ø8x25 mm  x4 257068	
---	---	---

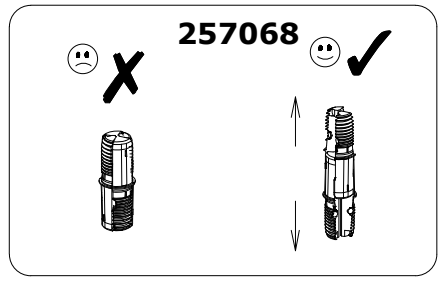
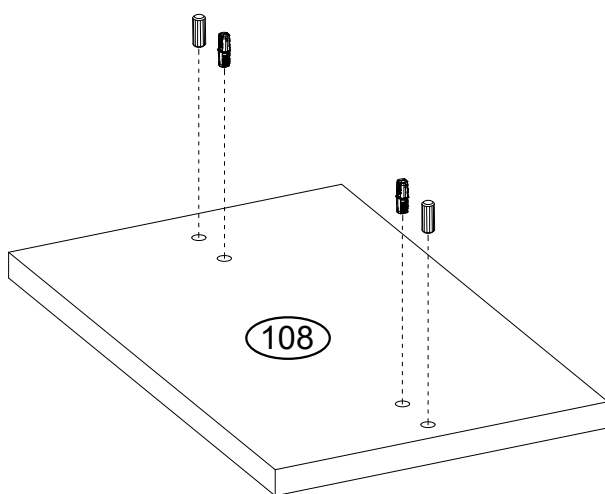
x2

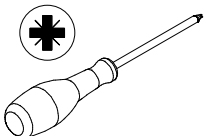

7

C	Ø15x12 mm  x6 3996	 
---	---	--

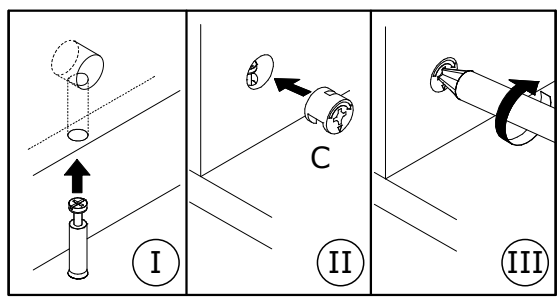
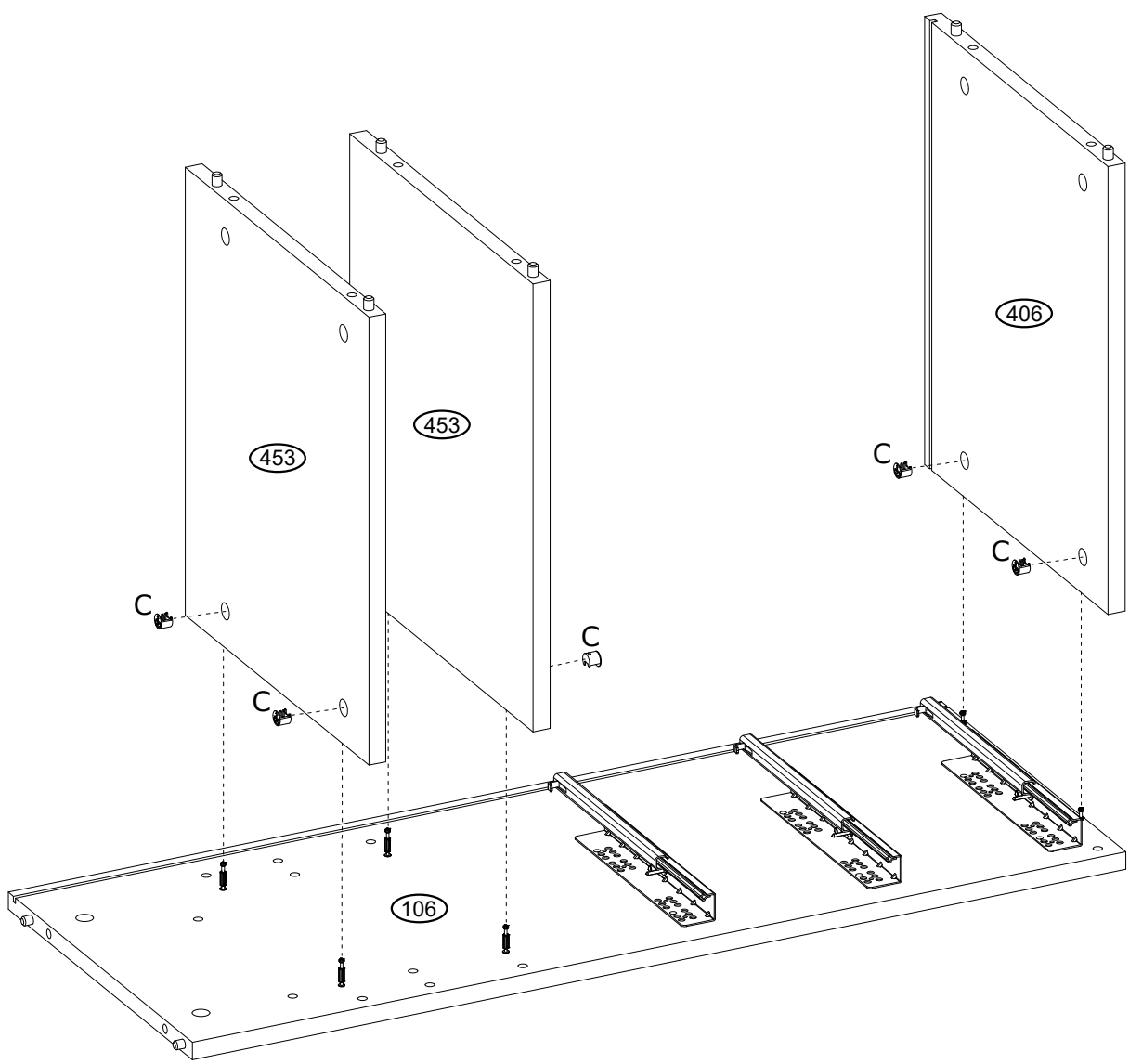

8

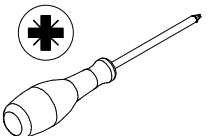
C	Ø15x12 mm  x6 3996	 
---	---	--

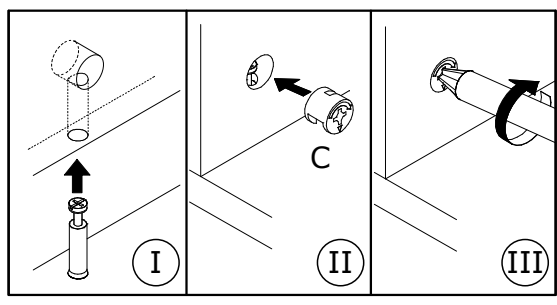
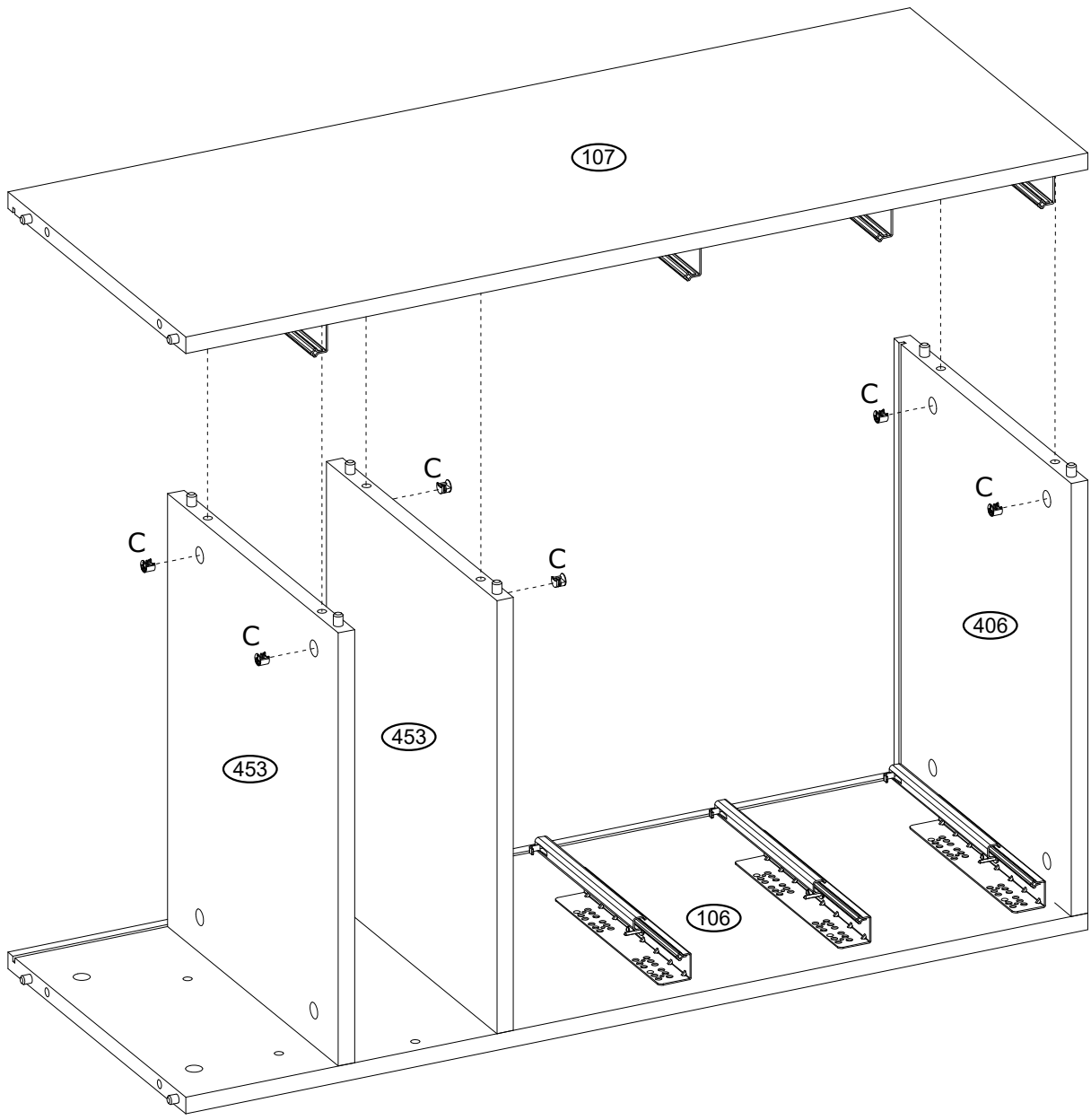

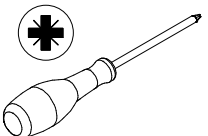

9

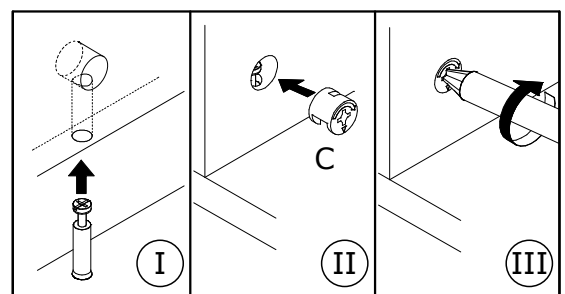
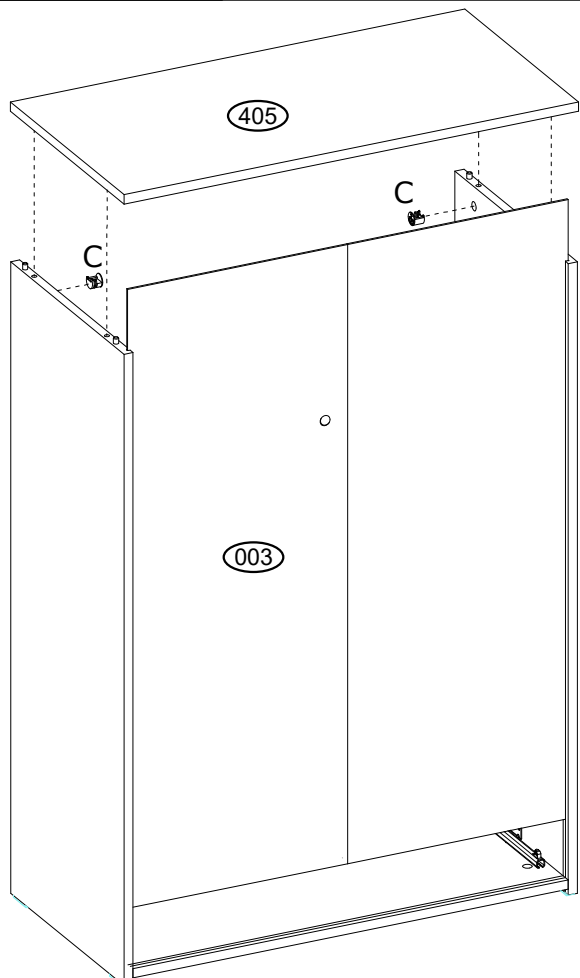
<p>C</p> <p>Ø15x12 mm</p>  <p>x4 3996</p>	
--	--

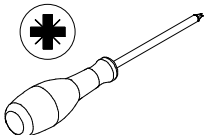

10

<p>E</p> <p>15x14x11 mm</p>  <p>x12 4044</p>	<p>L</p> <p>Ø3x20 mm</p>  <p>x8 3886</p>	
--	--	---

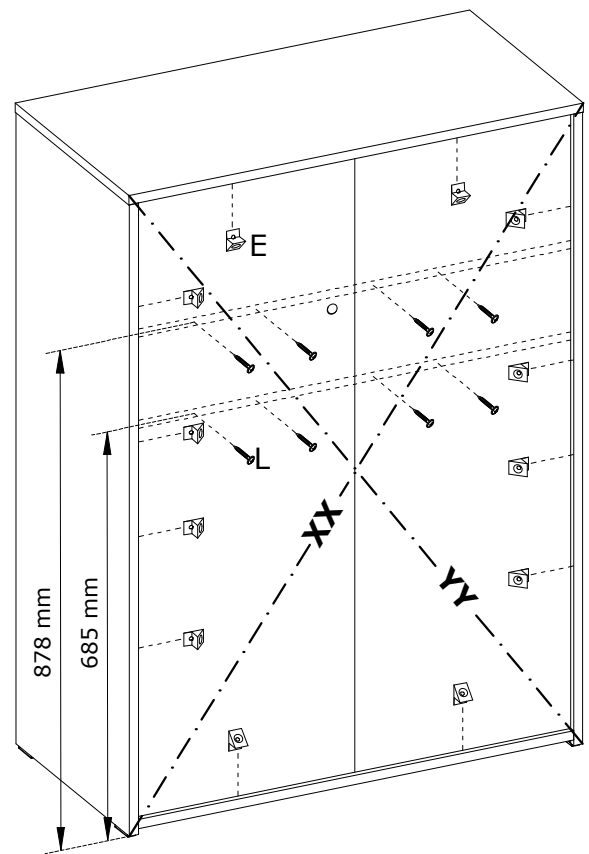
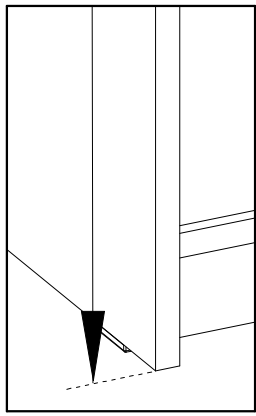
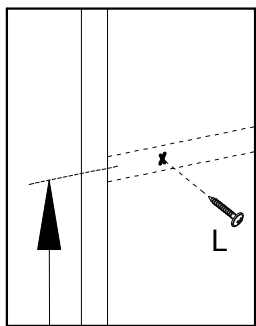

XX=YY=90°

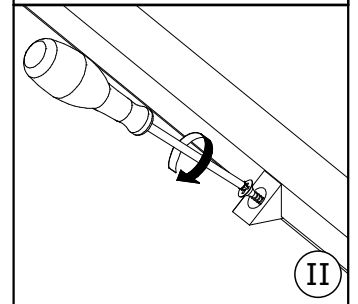
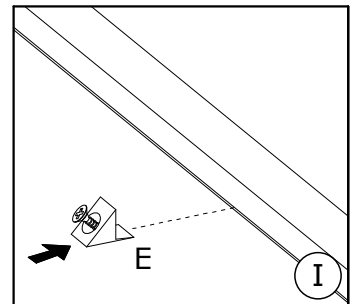

11

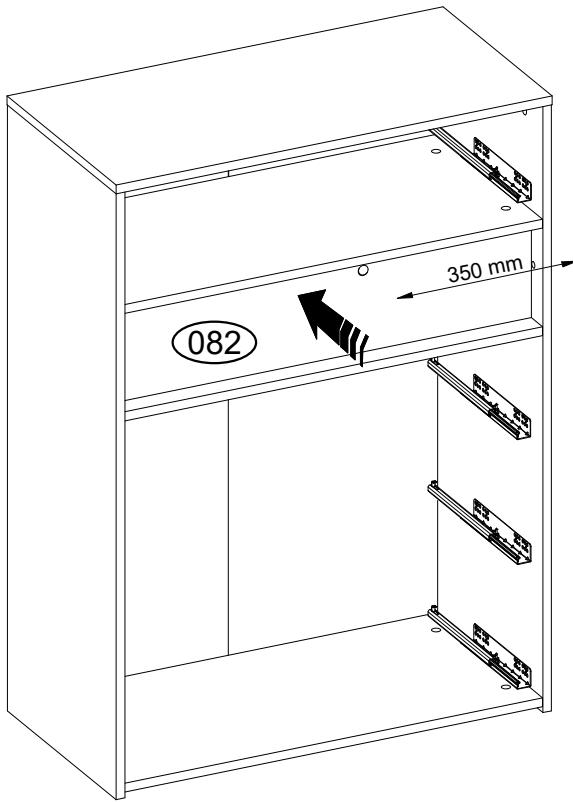

12

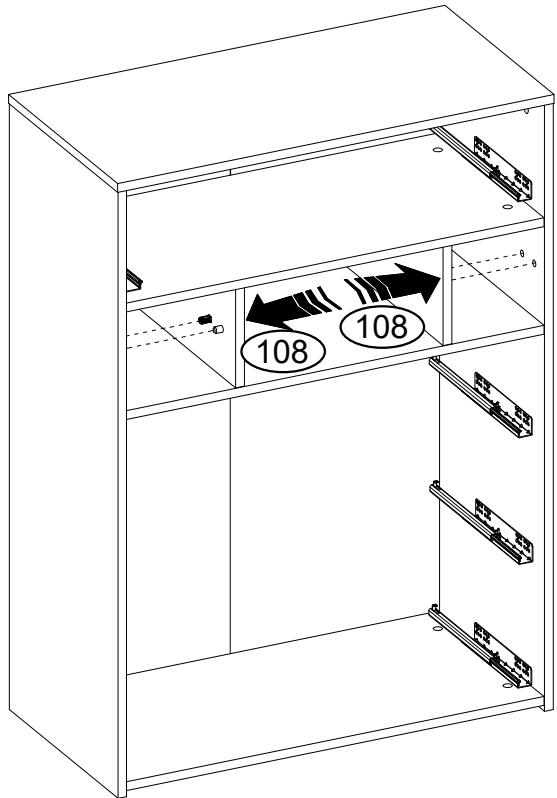
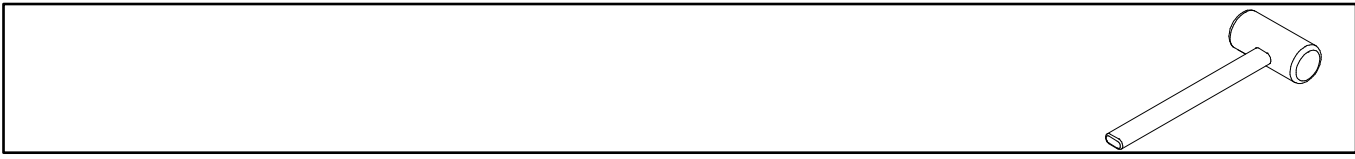

13

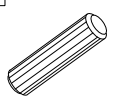
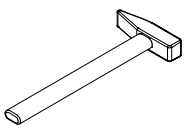
A	Ø8x30 mm  x8 92597	
---	---	--

x4

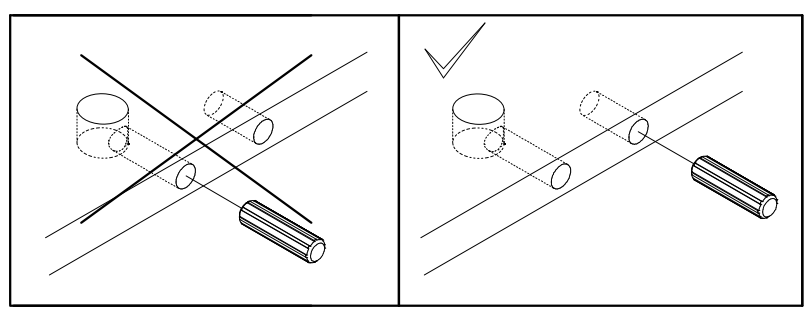
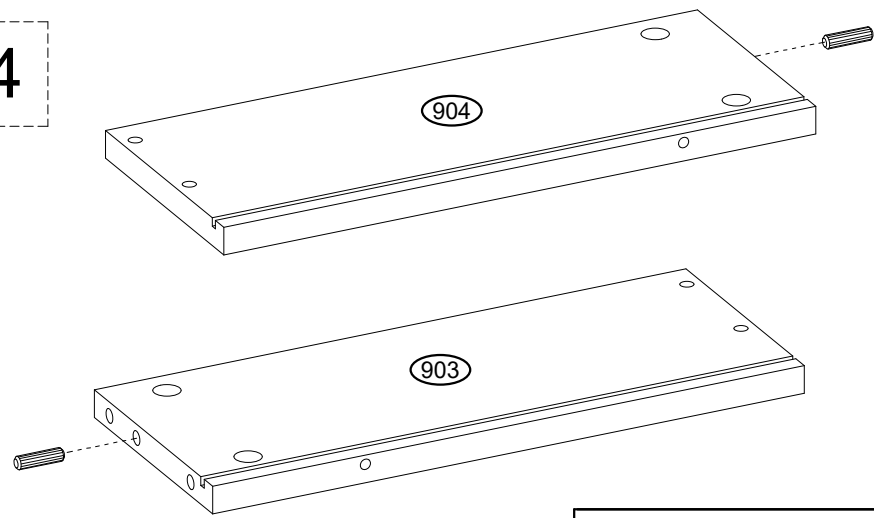

14

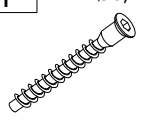
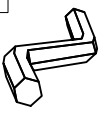
T	Ø6,4x50 mm  x16 3884	IM  4 mm
---	--	---

x4

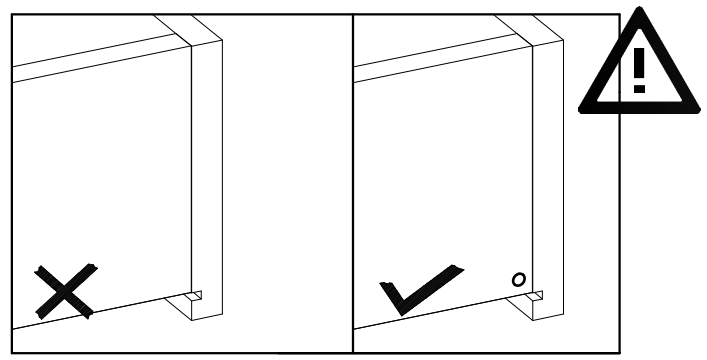
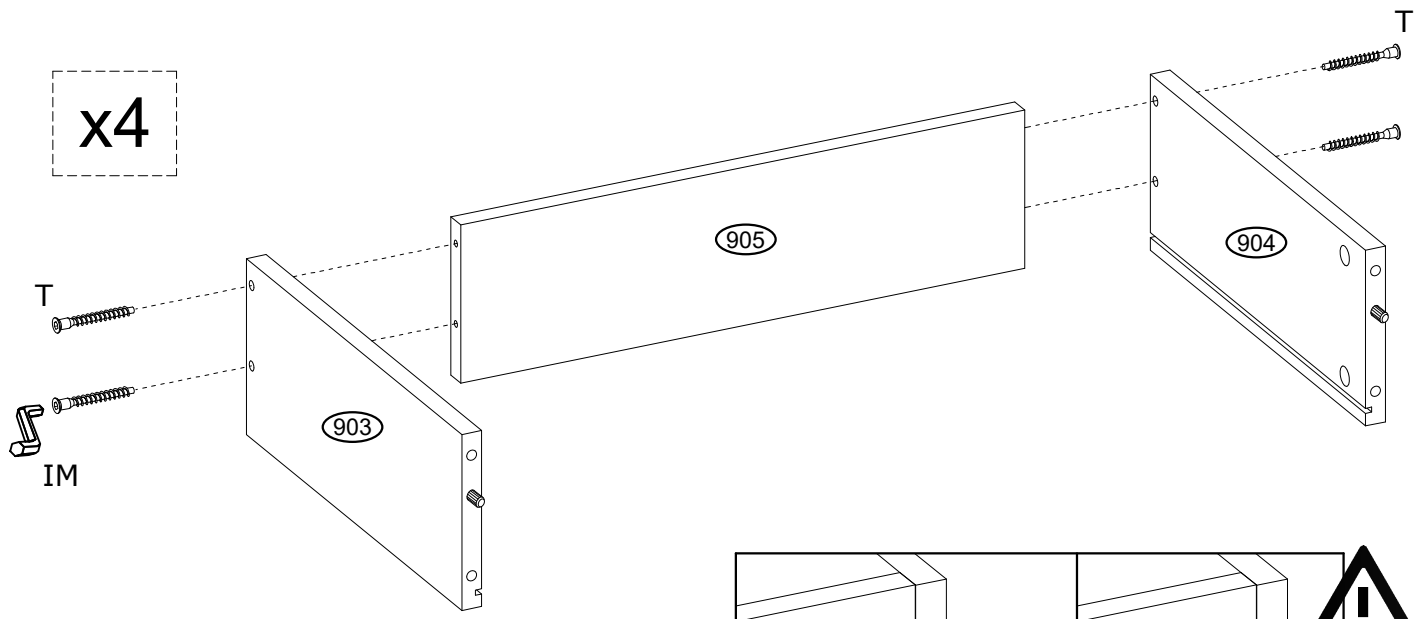

15

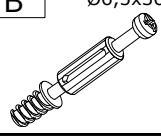
B	$\varnothing 6,5 \times 36,5$ mm  x16 4066	
----------	--	--

x4

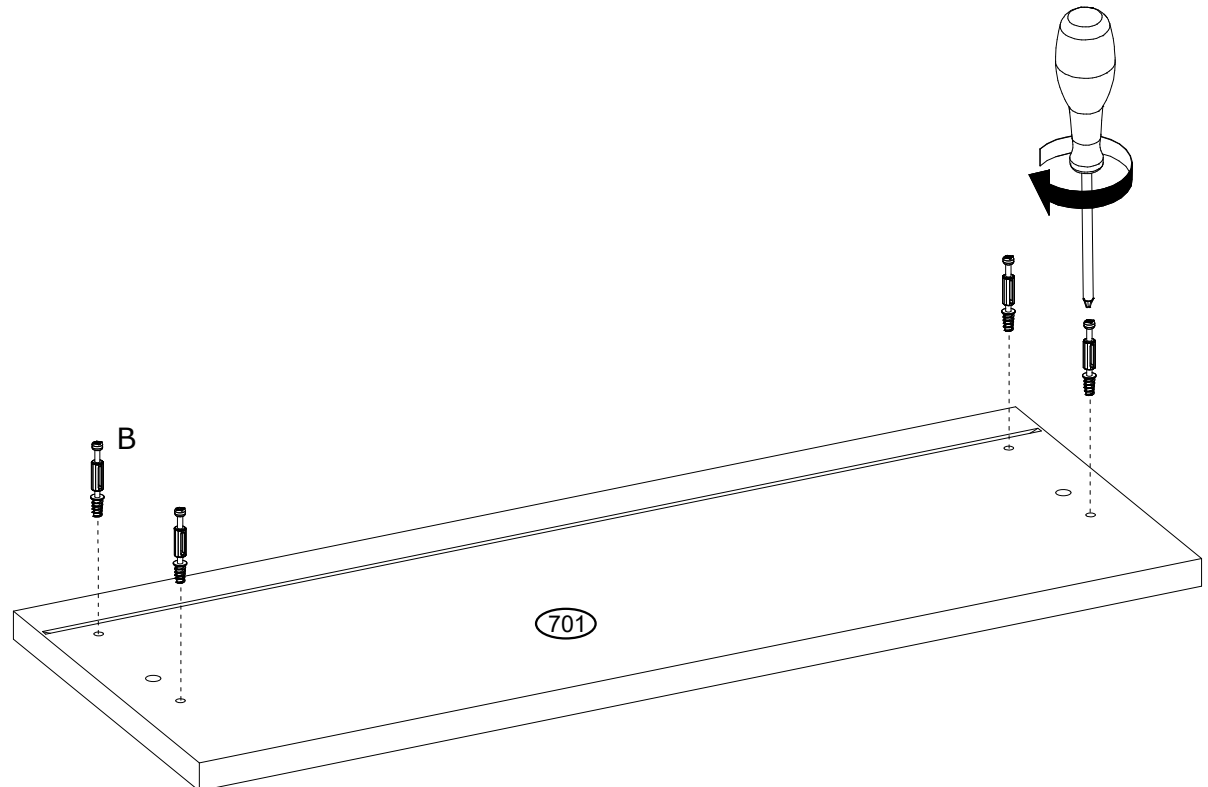

16

C	$\varnothing 15 \times 12$ mm  x16 3996	
----------	--	---

x4

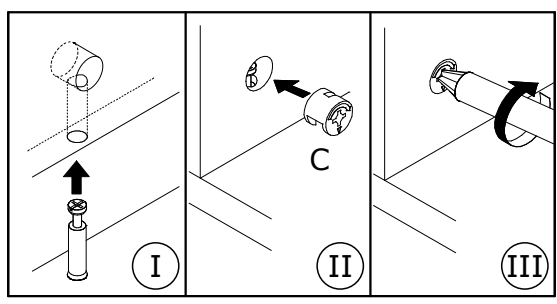
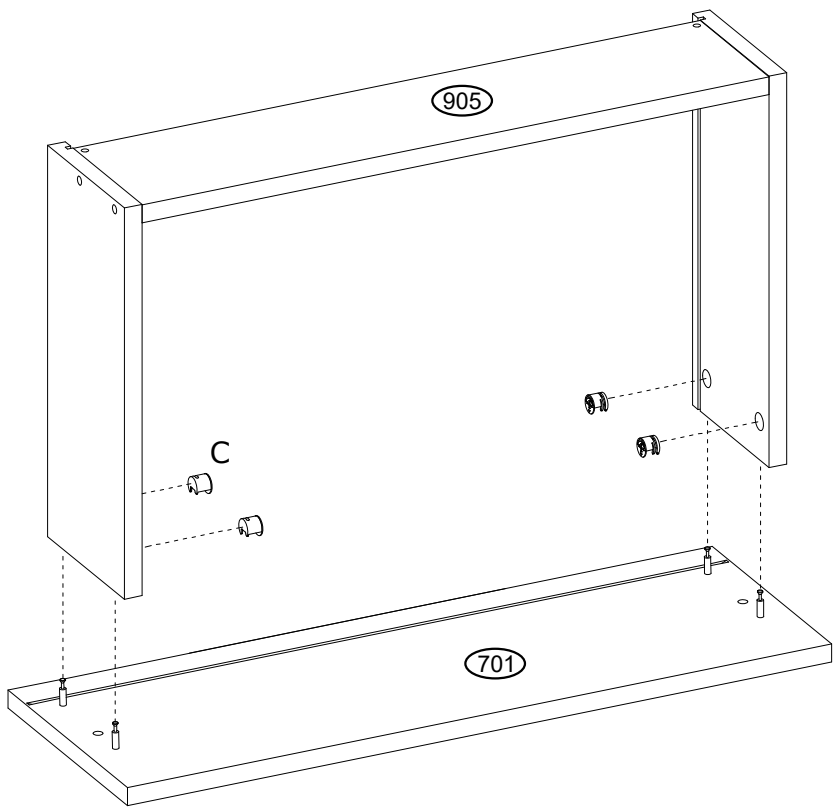

17

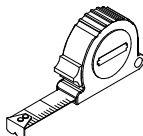
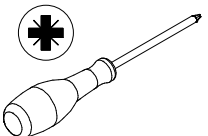
L	Ø3x25 mm		x20 3887		
---	----------	--	-------------	--	--

x4

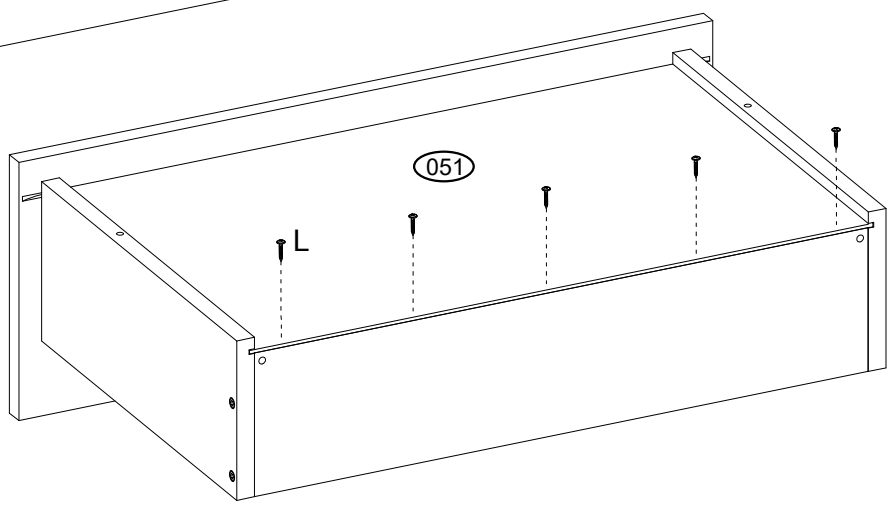
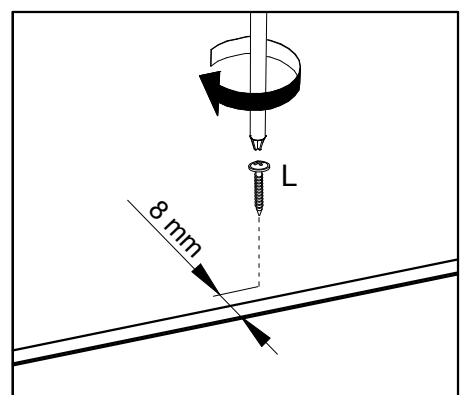
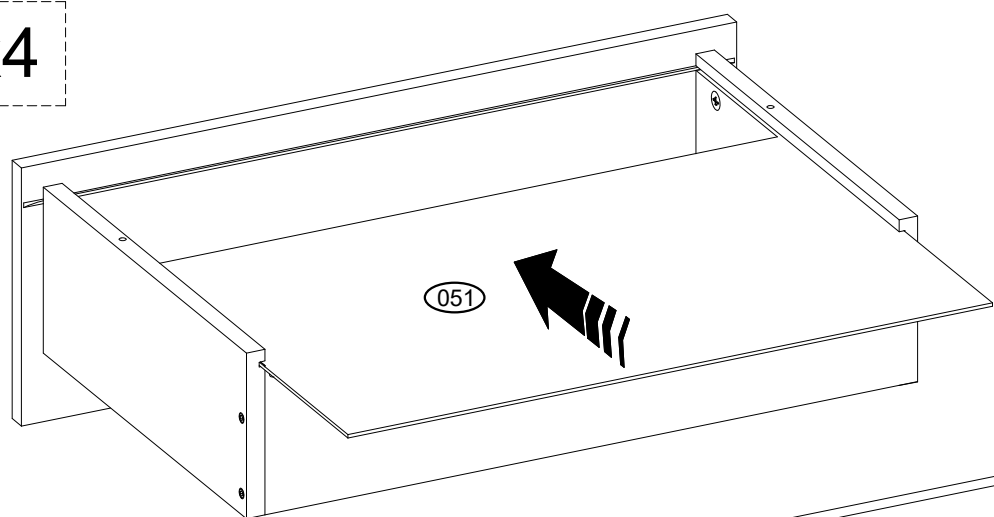

18

K	Ø3,5x16 mm	WS	350 mm		x8 3918		x4 185476		
---	------------	----	--------	---	------------	---	--------------	---	---

x4

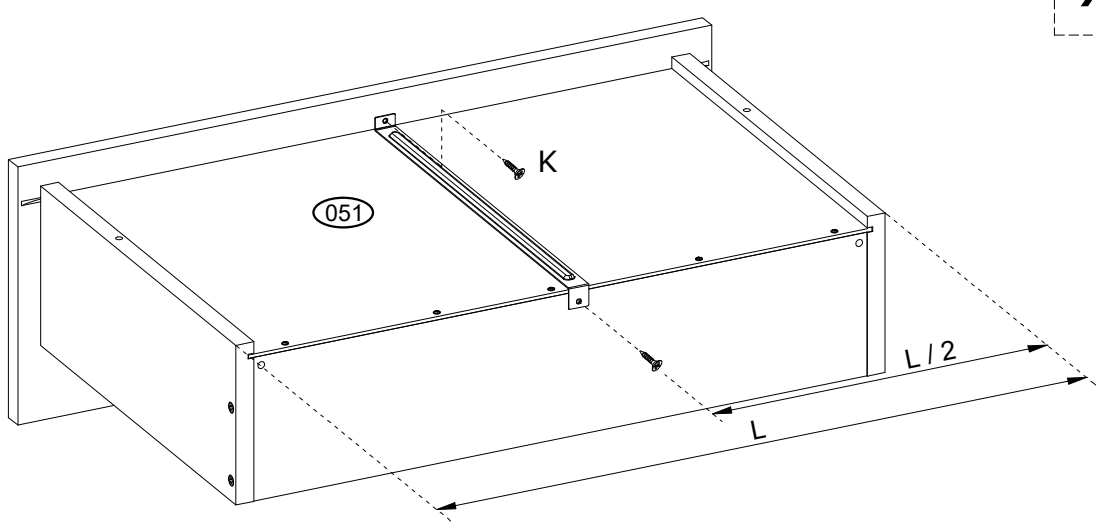

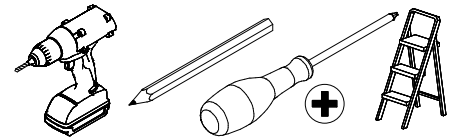
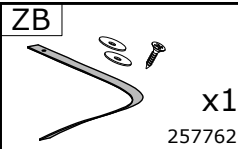

ACHTUNG - WARNING - ATTENTION - ATTENZIONE - AANDACHT - UWAGA - POZOR - POZOR - FIGYELEM - ATENȚIE - ДІККАТ - ВНИМАНИЕ - ПАЖЬА - RAŽNJA - POZOR - DĚMESIO - UZMAŅĪBU - TĀHELEPANU - ATENCIÓN - ATENÇÃO

D - ACHTUNG: WARNUNG Umkippen zu vermeiden, muss dieses Produkt mit der mitgelieferten Wandhalterung verwendet werden.

GB - WARNING: WARNING In order to prevent overturning this product must be used with the wall attachment device provided.

FR - ATTENTION: AVERTISSEMENT Pour éviter le renversement, ce produit doit être utilisé avec le support de montage mural fourni.

IT - ATTENZIONE: AVVERTENZA Per evitare il ribaltamento, questo prodotto deve essere utilizzato con una staffa di montaggio a parete inclusa.

NL - AANDACHT: WAARSCHUWING Om kantelen te voorkomen, moet dit product worden gebruikt met de meegeleverde wandmontagebeugel.

PL - UWAGA: OSTRZEŻENIE Aby zapobiec przewróceniu, produkt ten musi być używany z dołączonym uchwytem do montażu ściennego.

CZ - POZOR: UPOZORNĚNÍ Aby se zabránilo převrácení, musí být tento výrobek používán s dodaným držákem pro montáž na stěnu.

SK - POZOR: OPOZORILO Da bi preprečili prevračanje, je treba ta izdelek uporabljati s priloženim nosilcem za pritrditev na steno.

HU - FIGYELEM: FIGYELMEZTETÉS A billenés megakadályozása érdekében ezt a terméket a mellékelt fali rögzítő konzollal kell használni.

RO - ATENȚIE: AVERTISMENT Pentru a preveni răsturnarea, acest produs trebuie să fie utilizat cu suportul de montare pe perete furnizat.

TR - DİKKAT: UYARI Devrilmeyi önlemek için, bu ürün birlikte verilen duvara montaj braketi ile kullanılmalıdır.

RU - ВНИМАНИЕ: ПРЕДУПРЕЖДЕНИЕ Для предотвращения опрокидывания, этот продукт необходимо использовать с прикрепленным кронштейном для настенного монтажа.

SRB - ПАЖЬА: УПОЗОРЕЊЕ Да бисте спречили превртање, овај производ мора да се користи са укљученом зидним заградом за монтажу.

HR - RAŽNJA: UPOZORENJE Da biste spriječili prevrtanje, ovaj se proizvod mora koristiti s priloženim zidnim nosačem.

SL - POZOR: UPOZORNENIE Aby sa zabránilo prevráteniu, tento výrobok sa musí používať s dodanou nástennou montážnou konzolou.

LT - DĚMESIO: ĮSPĖJIMAS Kad šis gaminyš neapvirštų, jis turi būti naudojamas su pridedamu sieniniu laikikliu.

LV - UZMAŅĪBU: BRĪDINĀJUMS Lai novērstu apgāšanos, šis izstrādājums jāizmanto kopā ar pievienoto sienas stiprinājuma kronšteinu.

EE - TĀHELEPANU: HOIATUS Kukkumise vältimiseks tuleb seda toodet kasutada koos kaasasoleva seinakinnitusklambriga.

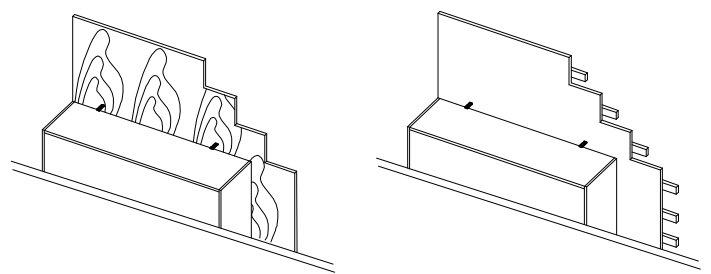
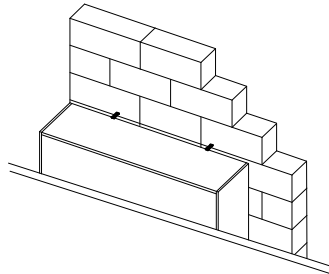
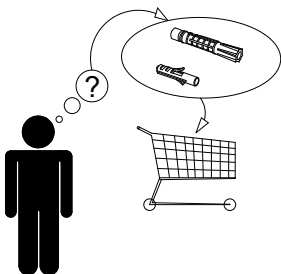
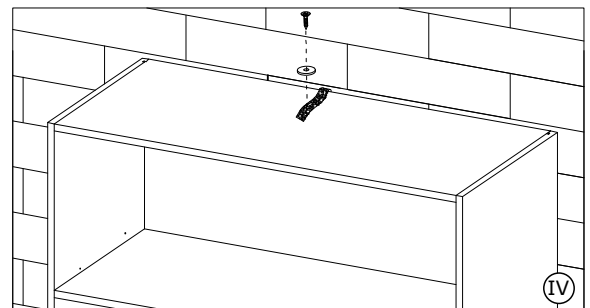
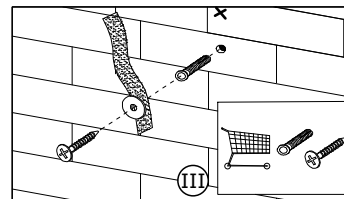
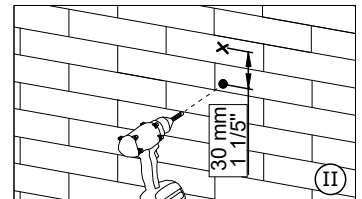
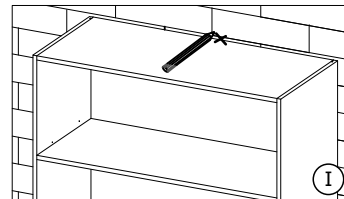
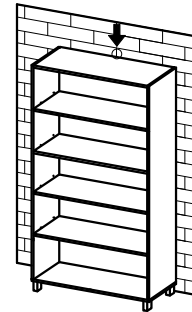
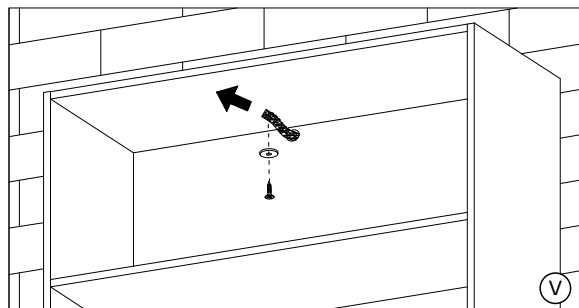
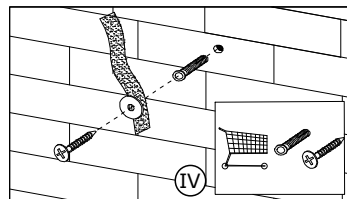
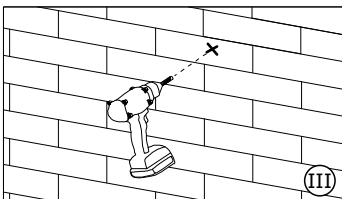
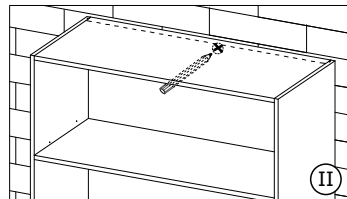
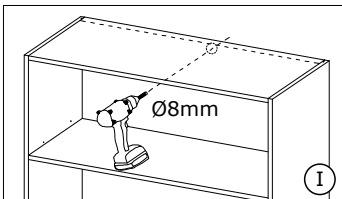
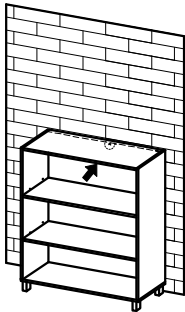

ES - ATENCIÓN! ADVERTENCIA Para evitar que se vuelque, este producto debe utilizarse con el soporte de montaje en pared proporcionado.

PT - ATENÇÃO! AVISO Para evitar o tombamento, este produto deve ser utilizado com o suporte de montagem na parede fornecido.

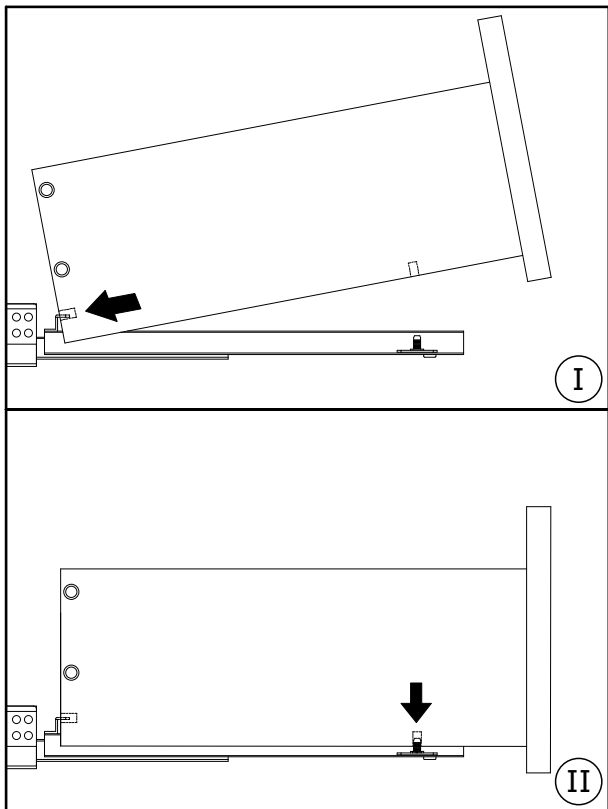
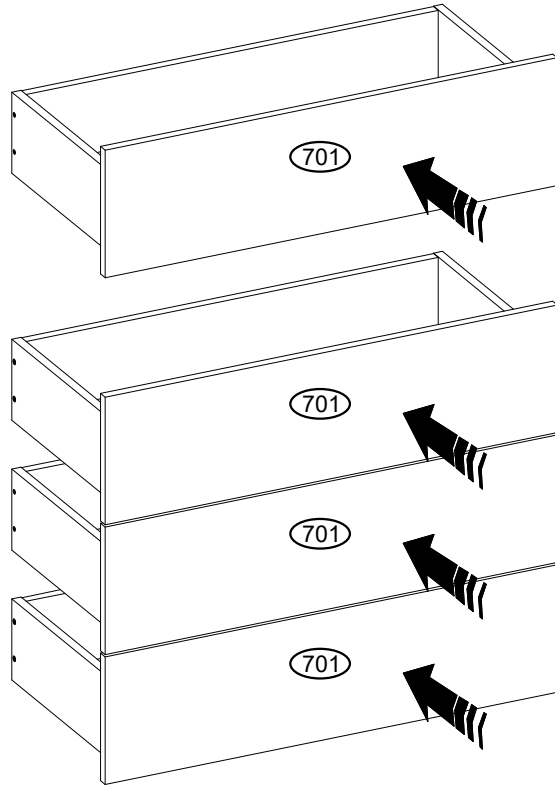
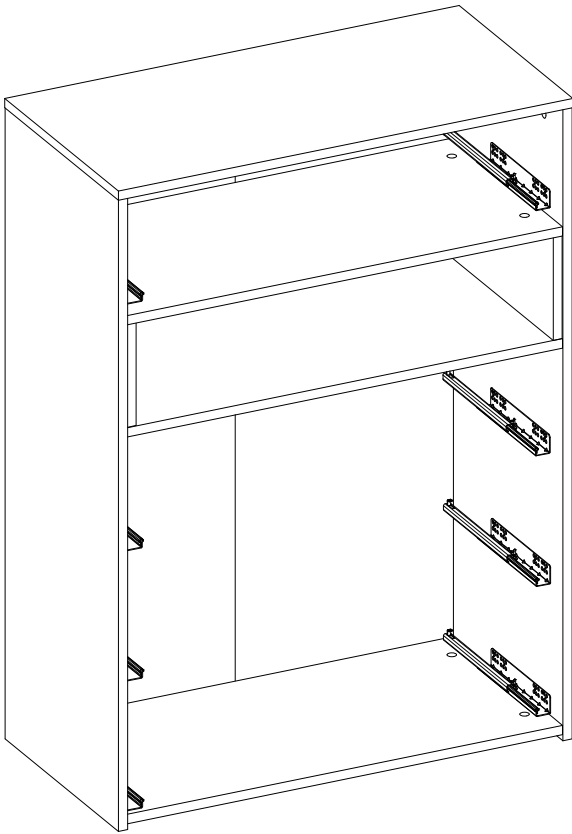

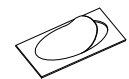

21

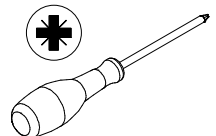
D Ø20 mm  x16 136239	L Ø3x20 mm  x8 3886	
--	---	--

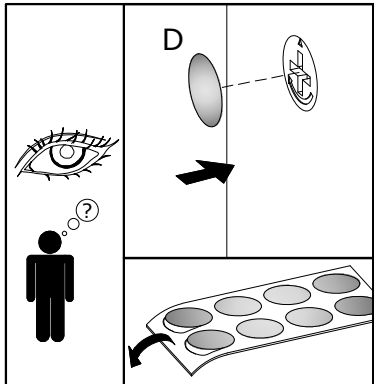
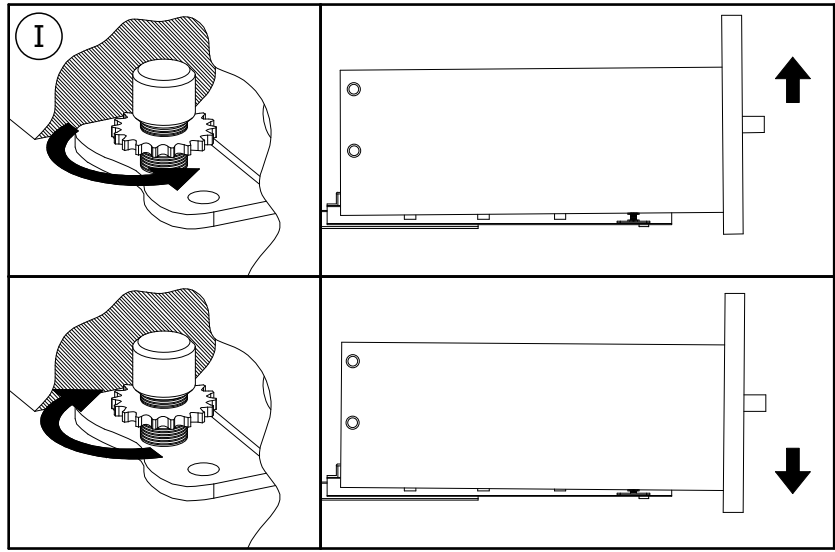
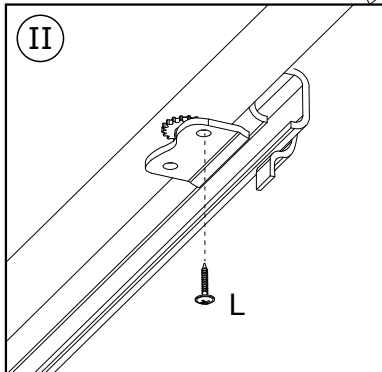
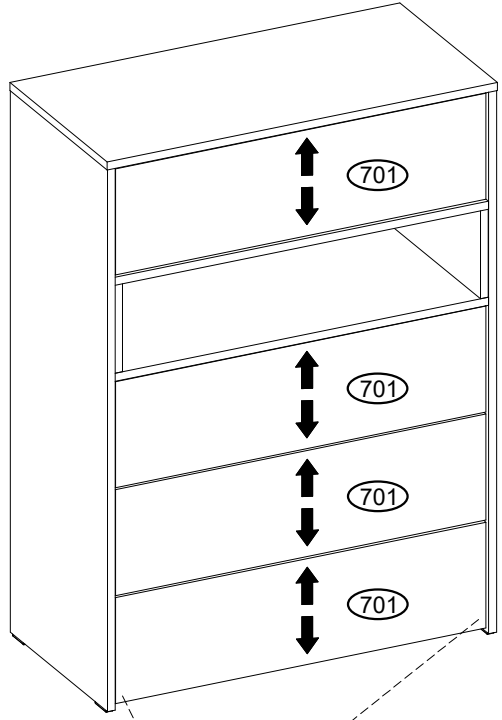

VILLA

Option, Option, Option, Optie, Volba, Opció, Seçenek, Võimalus, Опција, Možnost, Možnosť, Variantas, Opcja, Opzione, Opțiune, Вариант, Opção, Opcija, Opcija, Opción, Опция

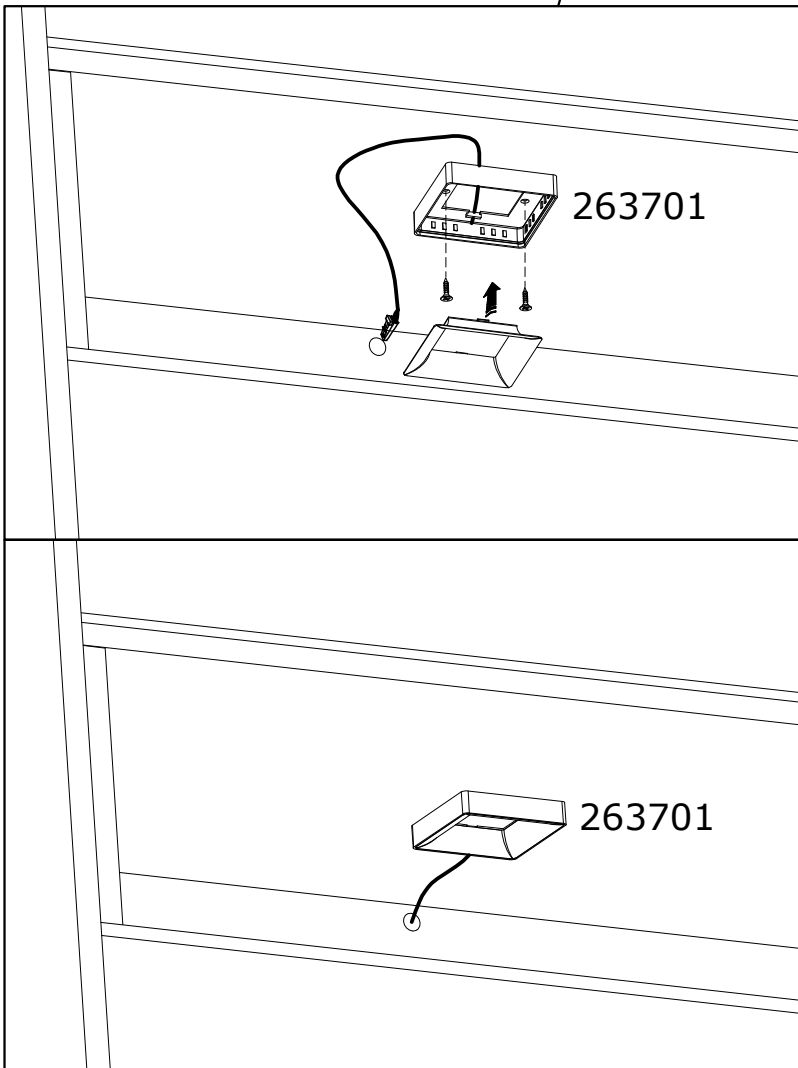
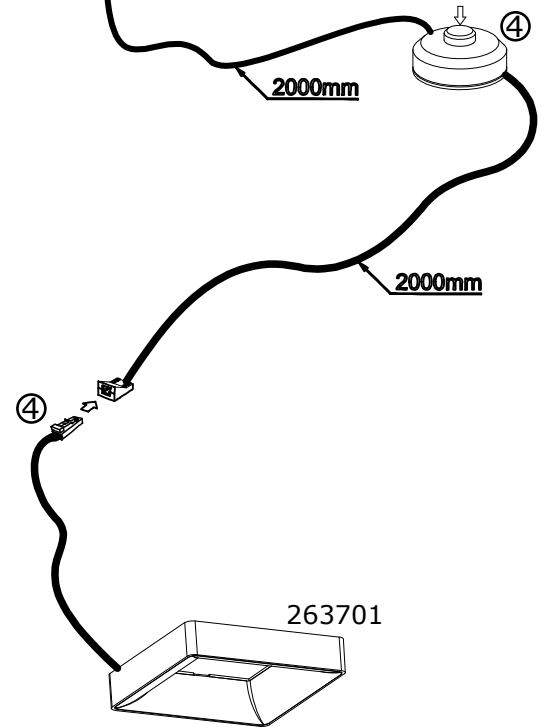
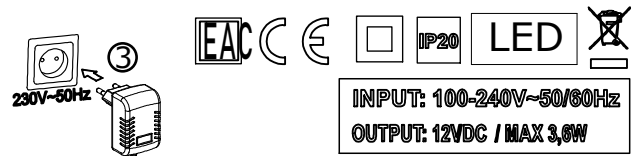
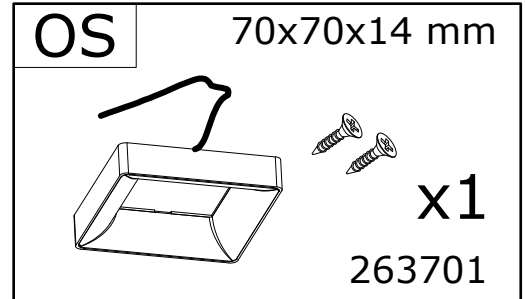
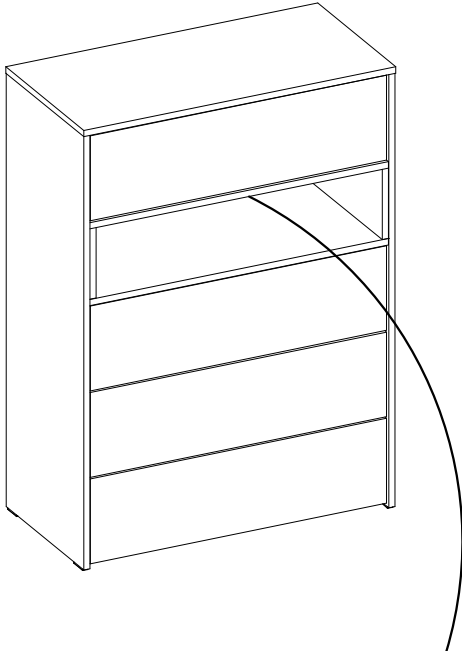

- D** Sicherheits- und Pflegehinweise
- FR** Conseils de sécurité et d'entretien
- NL** Veiligheids- en onderhoudstips
- CZ** Tipy pro bezpečnost a údržbu
- HU** Biztonsági és karbantartási tanácsok
- TR** Güvenlik ve bakım ipuçları
- ES** Instruções de segurança e manutenção
- SRB** Савети за безбедност и одржавање
- SL** Nasveti za varnost in vzdrževanje
- LV** Drošības un apkopes padomi

- GB** Safety and maintenance tips
- IT** Consigli per la sicurezza e la manutenzione
- PL** Wskazówki dotyczące bezpieczeństwa i konserwacji
- SK** Tipy na bezpečnosť a údržbu
- RO** Sfaturi de siguranță și întreținere
- RU** Советы по безопасности и обслуживанию
- PT** Instruções de segurança e manutenção
- HR** Savjeti za sigurnost i održavanje
- LT** Saugos ir priežiūros patarimai
- EE** Ohutus- ja hooldusnõuanded

