

SILK TYP 31, TYP 40

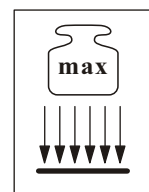

NO	Dim.			Col.-No	Qty
1K	696	246	16	2 / 3.	1
1P	212	318	4	2 / 3.	1
1B	212	255	4	2 / 3.	1
2	250	283	22	4 / 3.	2
2L	277	218	22	5 / 3.	1
2P	218	284	16	2 / 3.	1
3	800	284	22	2 / 3.	1
3D	1000	284	16	2 / 3.	1
5L	299	218	22	2 / 3.	1
5P	230	674	3	2 / 3.	1
7	1000	284	16	2 / 3.	1

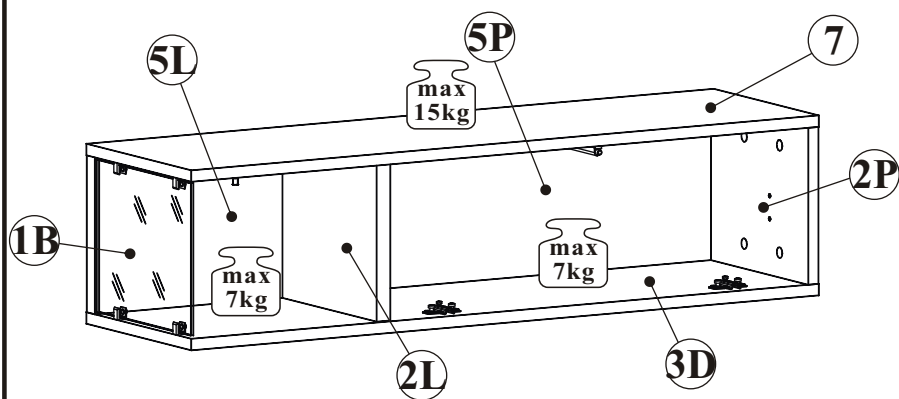
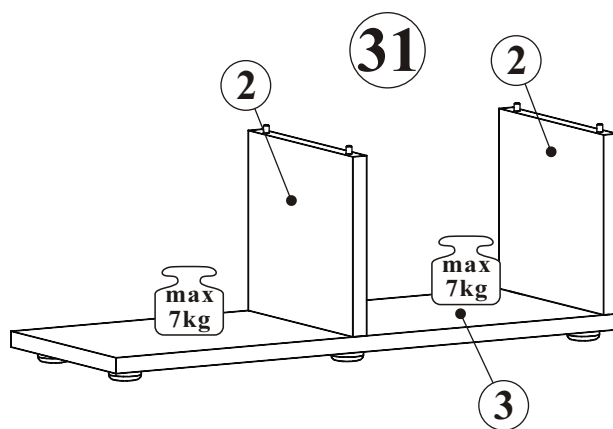
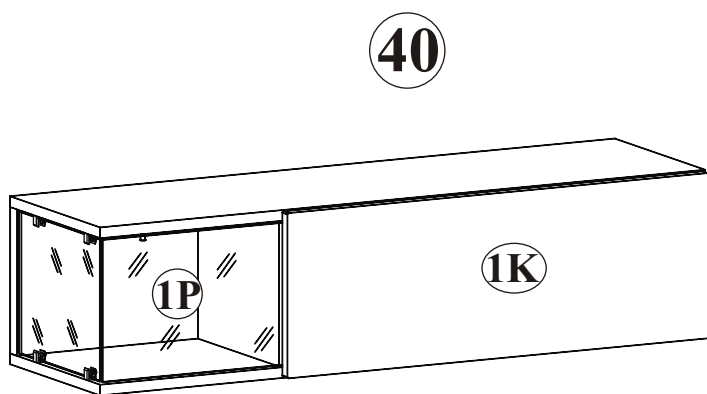
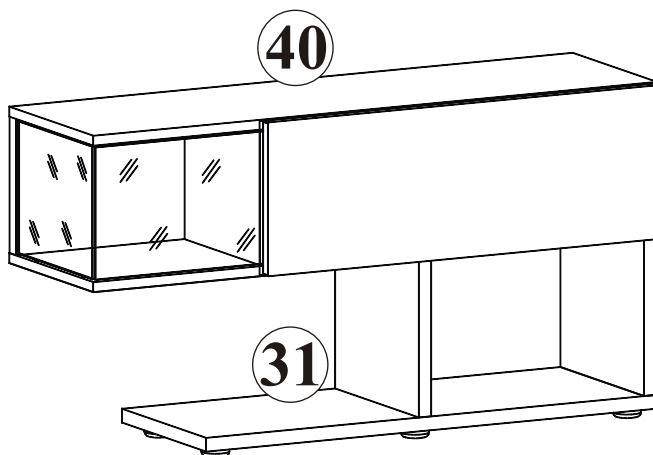
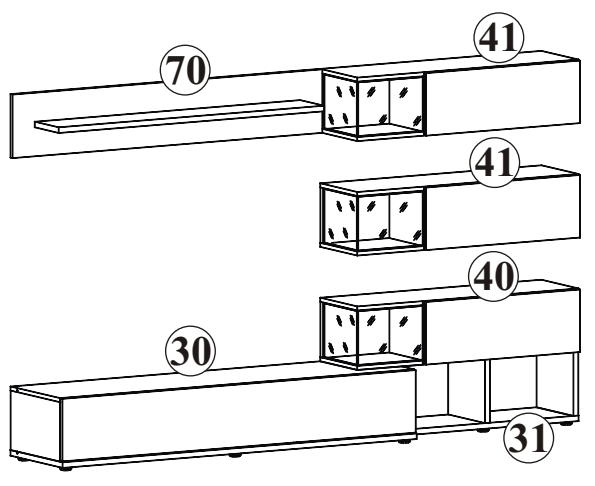
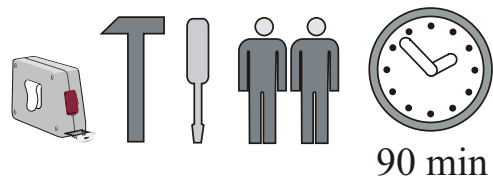

SILK TYP 31, TYP 40

A1 x20 ø8x36	B4 x12	B5 x4 Ø15x12	B16 x8 Ø15x16	G5 x12	B11 x4 Ø7x50
E21 x2 Ø35 H=0	E2 x2 H=0	D10 x11 USØ3,5x13	G21 x1	D7 x3 USØ3x16	G4 x4
I11 x6 Ø50, h=25	UP15 x6 UPØ4x25	G20 x1	G32 x4	P2 x3	UP13 x3 UPØ3x16
S1 x6	OD2 x1	KR1 x1	L1 x1	G2 x1	UP6 x2 UPØ4x30

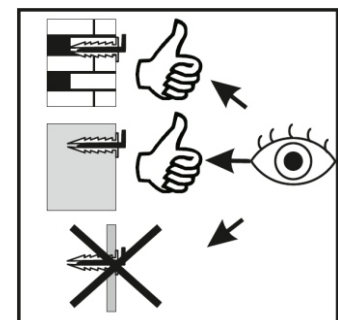
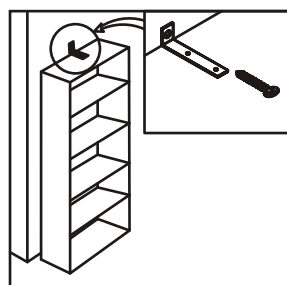
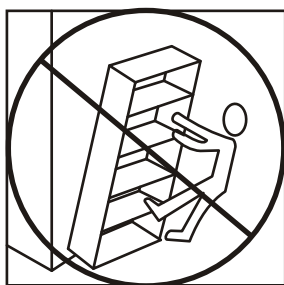
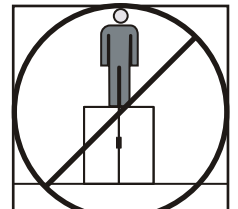
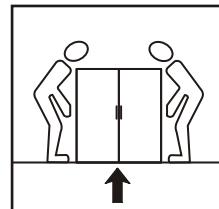
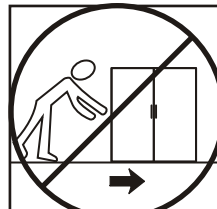
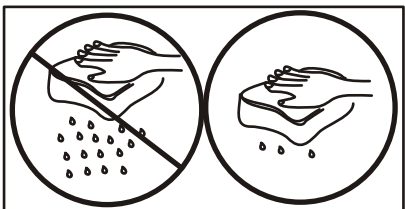
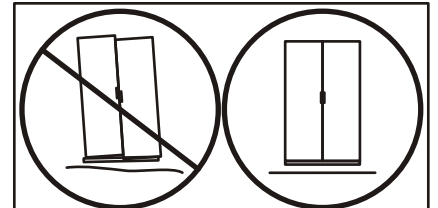
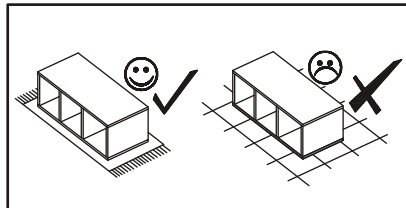
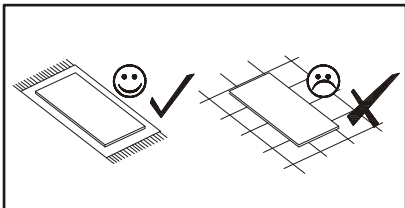
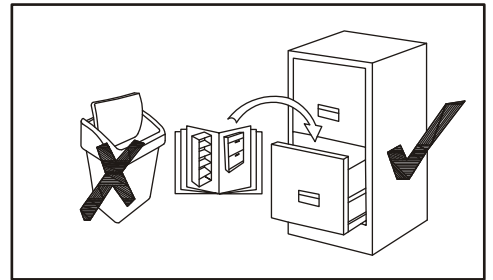
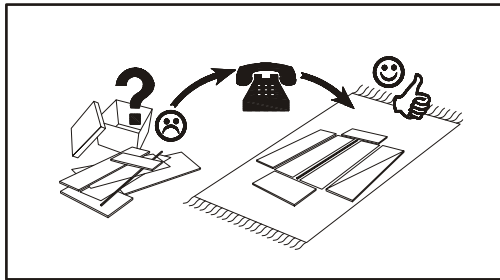
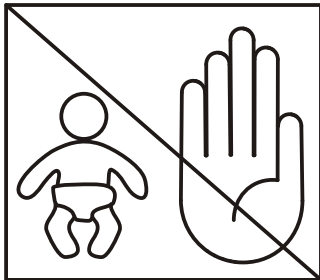
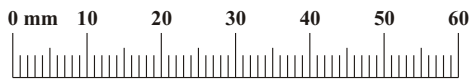

1 - 3

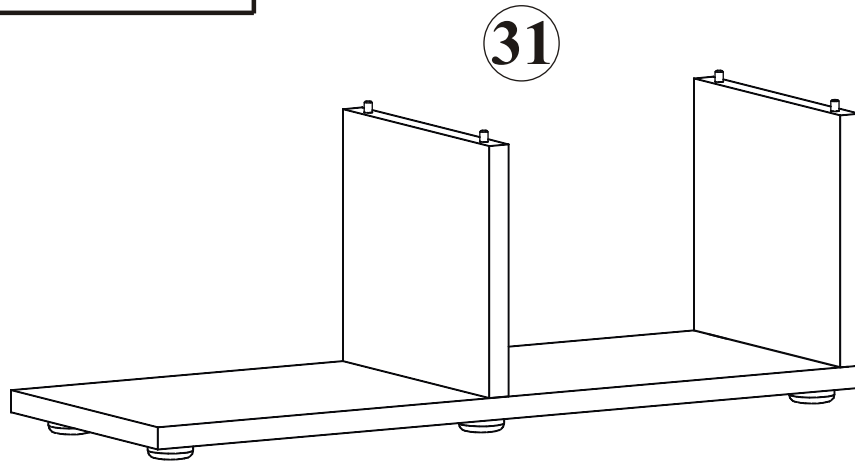

31

4 - 15

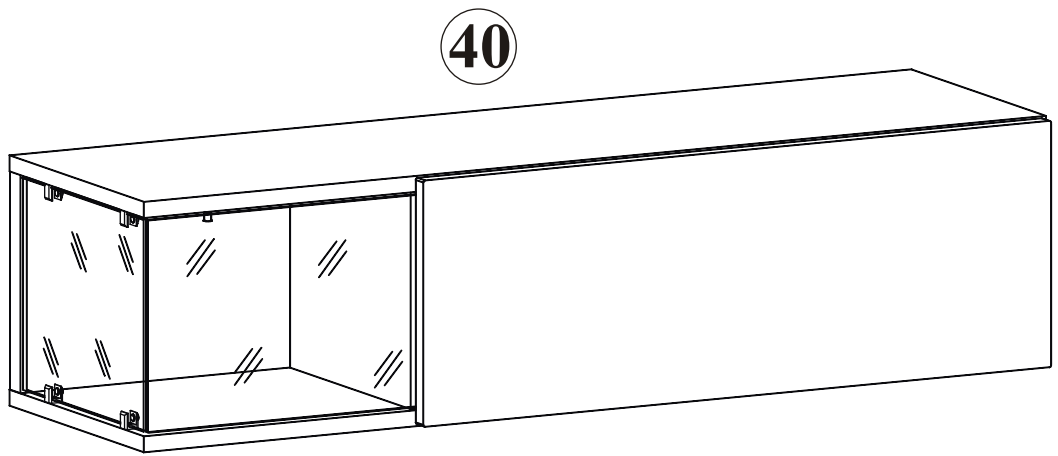

40

16 - 17

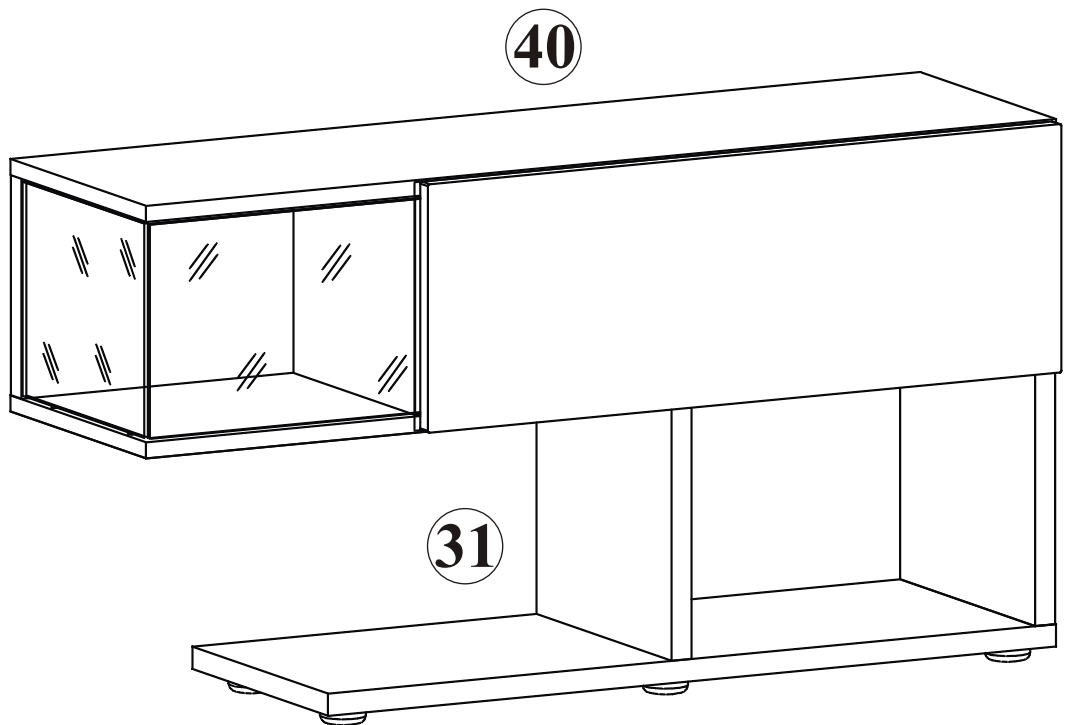

40

31

SILK TYP 31

1

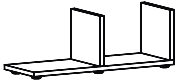

A1

x8

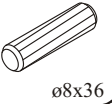

ø8x36

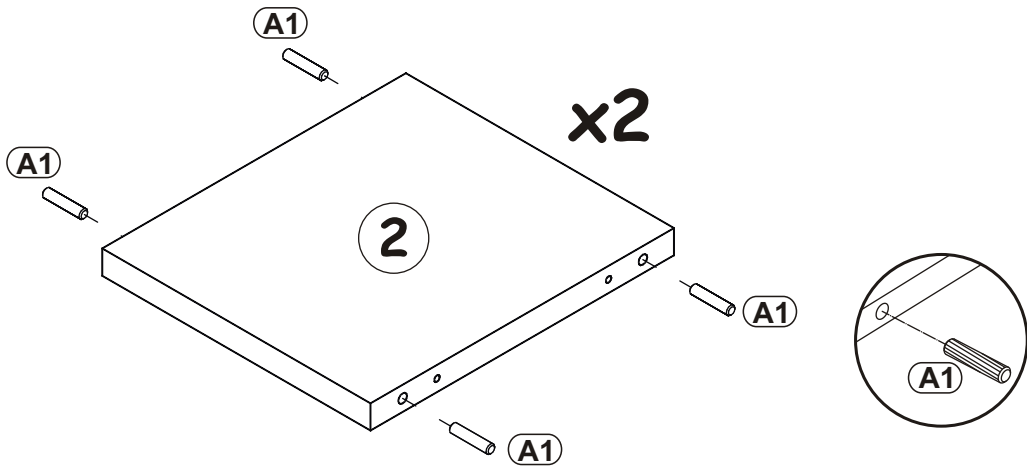

2

B11

x4



Ø7x50

G4

x4

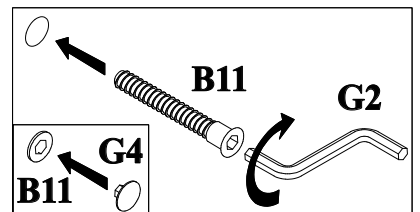
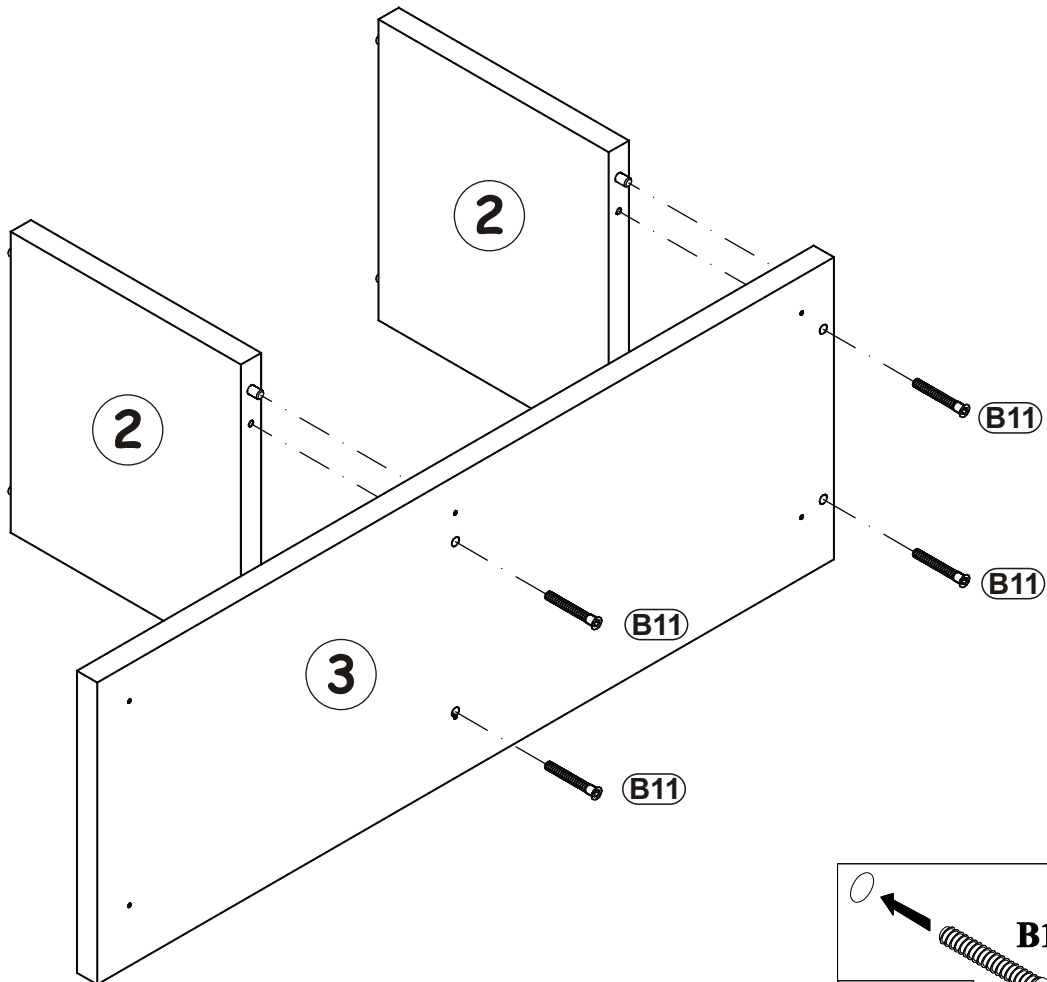

SILK TYP 31

3

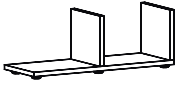

I11		UP15	
x6	Ø50, h=25	x6	UPØ4x25

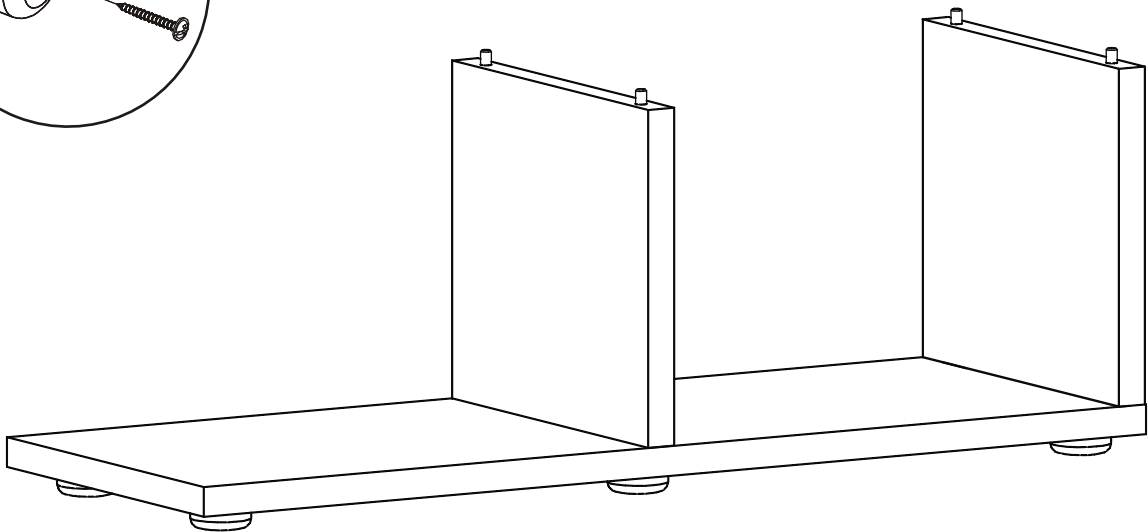
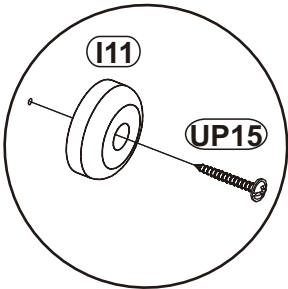
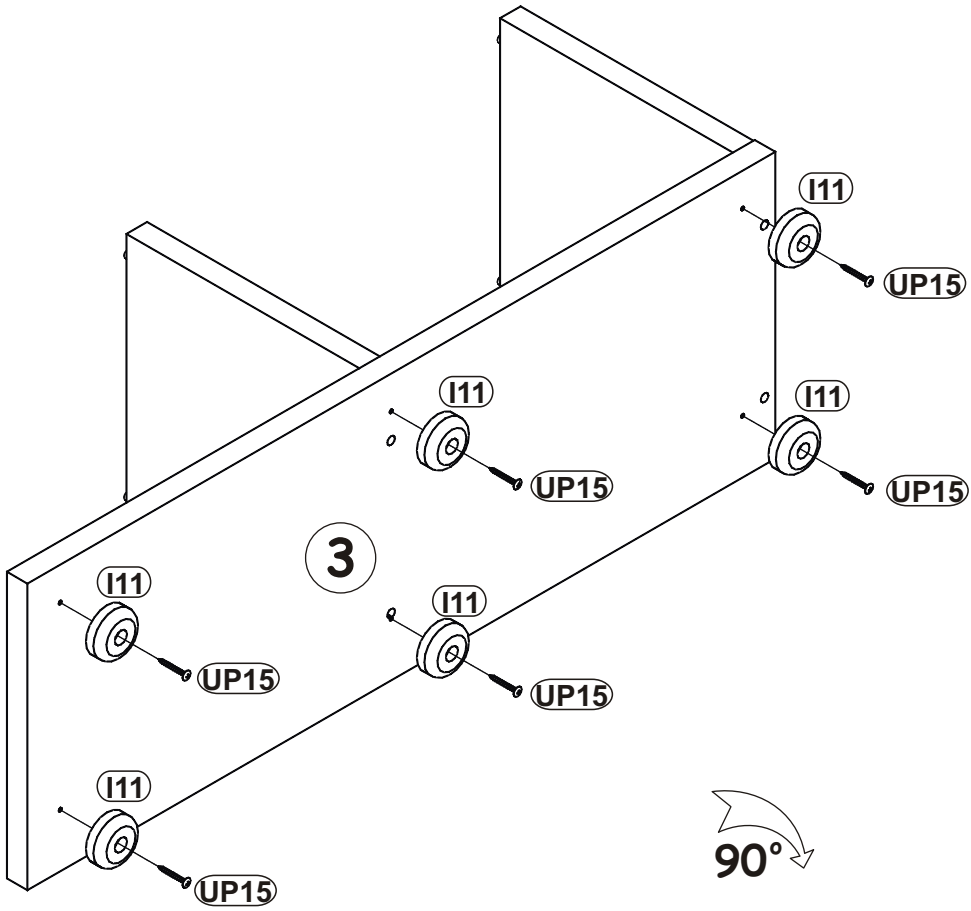

SILK TYP 40

4

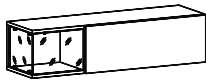

A1	
x8	ø8x36

B16	
x8	Ø15x16

12mm	16mm
B5	B16

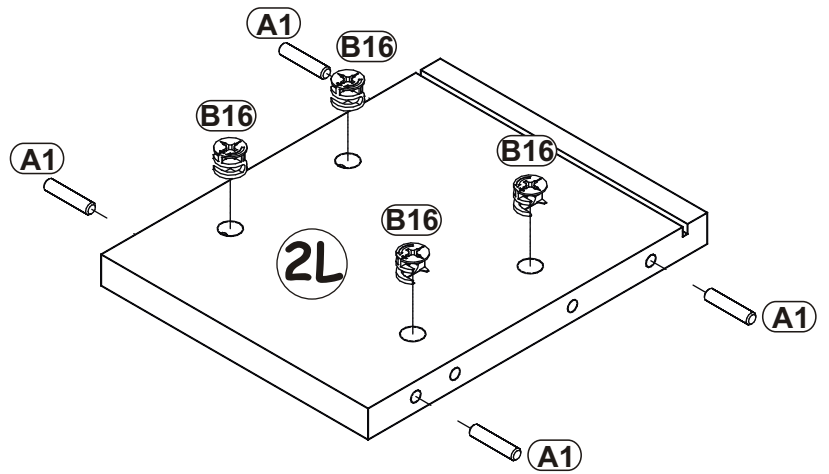
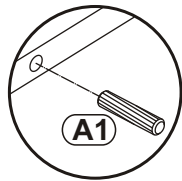
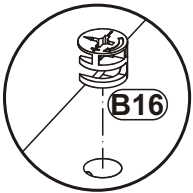
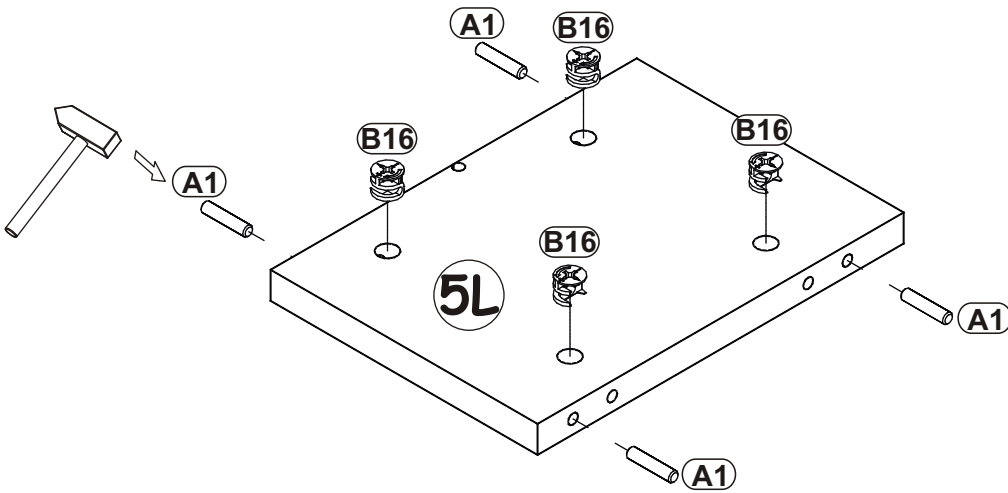

5



A1	
x4	ø8x36

B5	
x4	Ø15x12

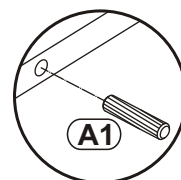
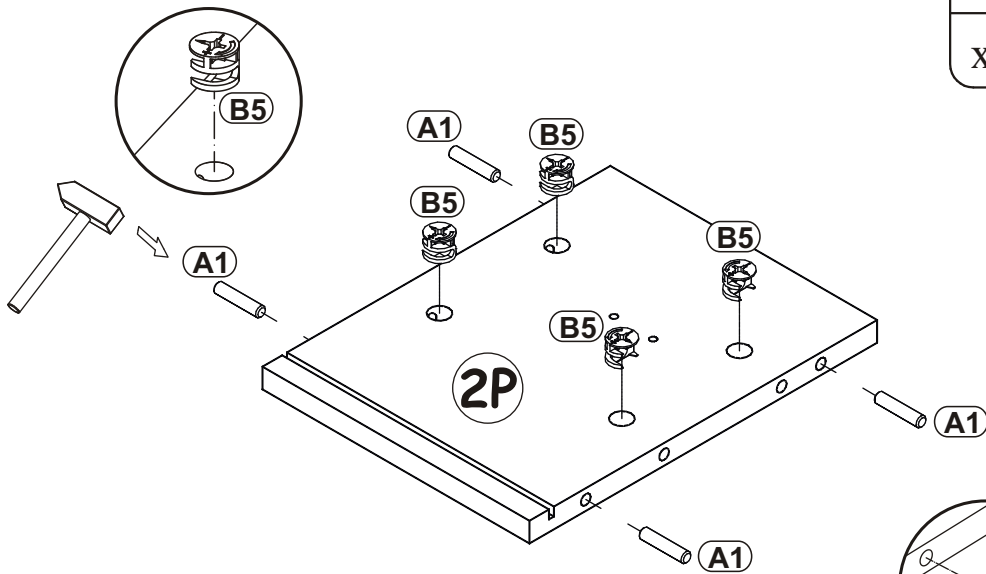
12mm	16mm
B5	B16

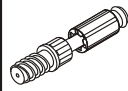

SILK TYP 40

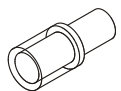
B4		G32		G20	
x6		x2		x1	

6

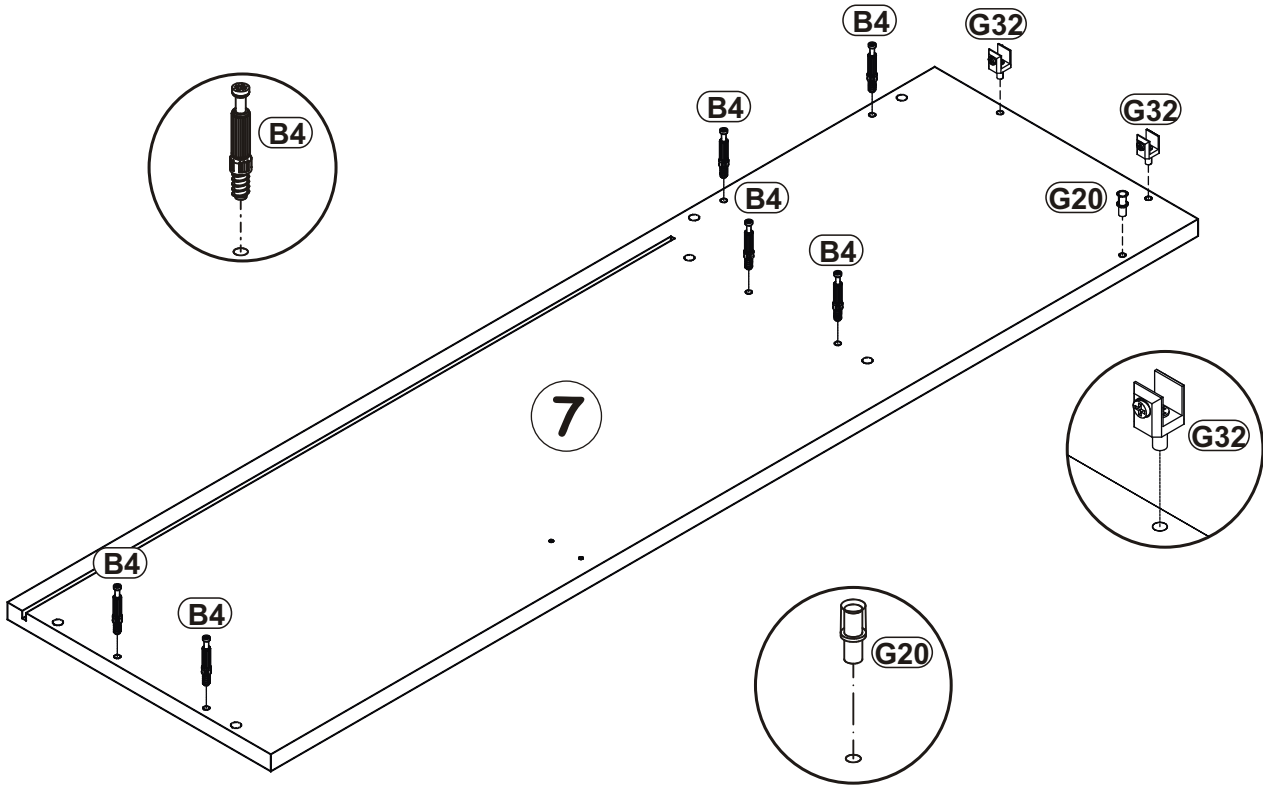
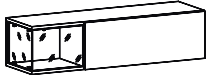

7

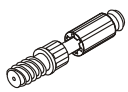
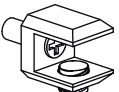
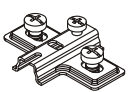
B4		G32		E2	
x6		x2		x2	H=0

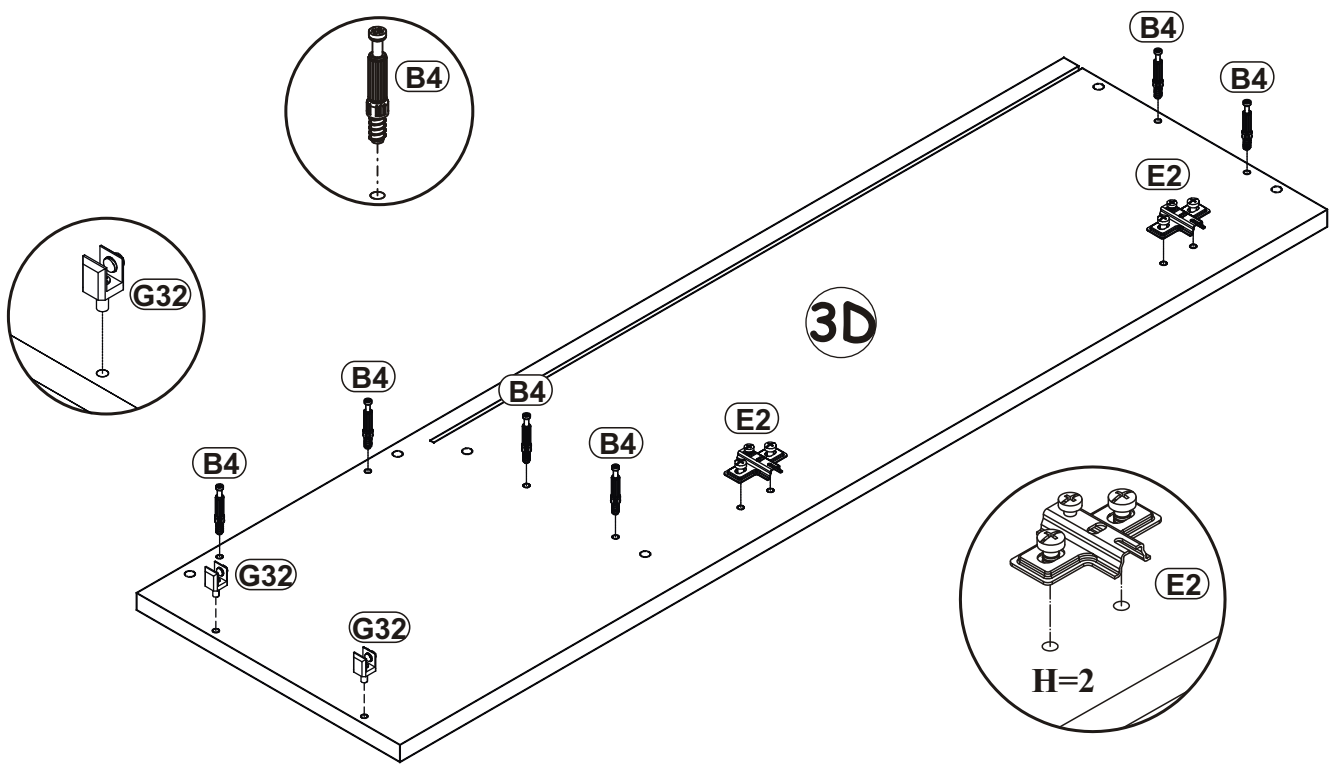

SILK TYP 40

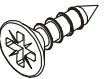
E21	Ø35	D10	 USØ3,5x13
x2	H=0	x4	

8

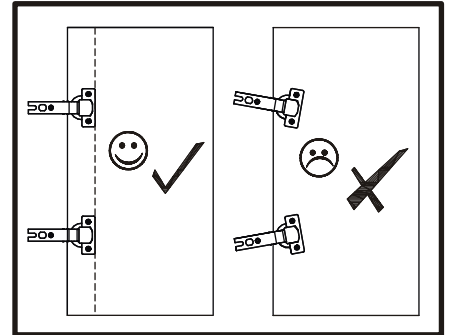
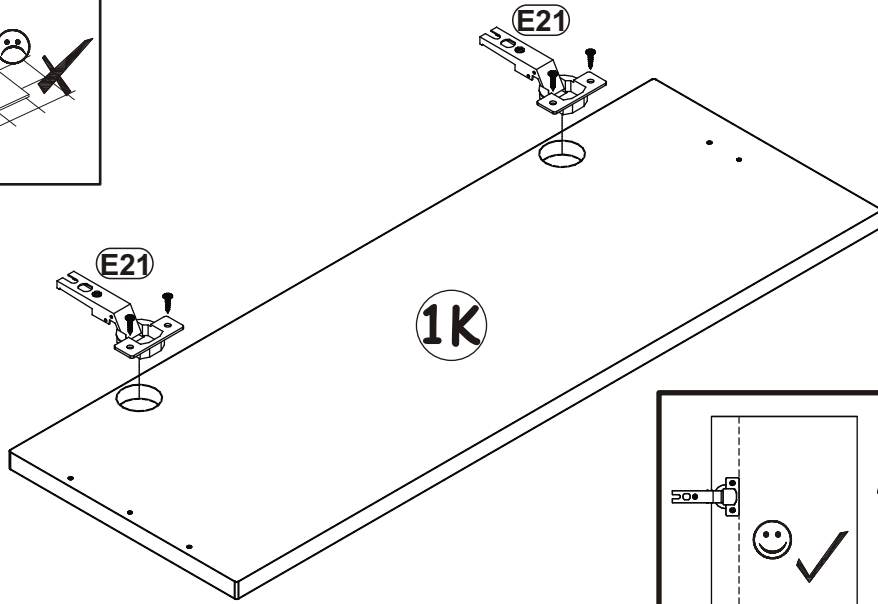
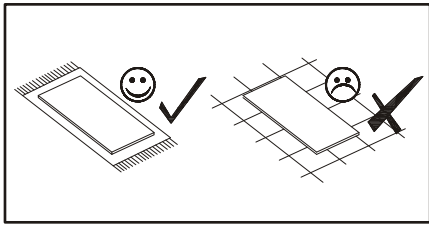
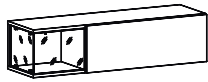

9

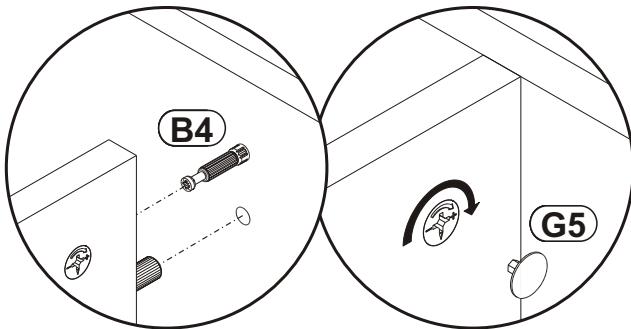

G5	
x6	

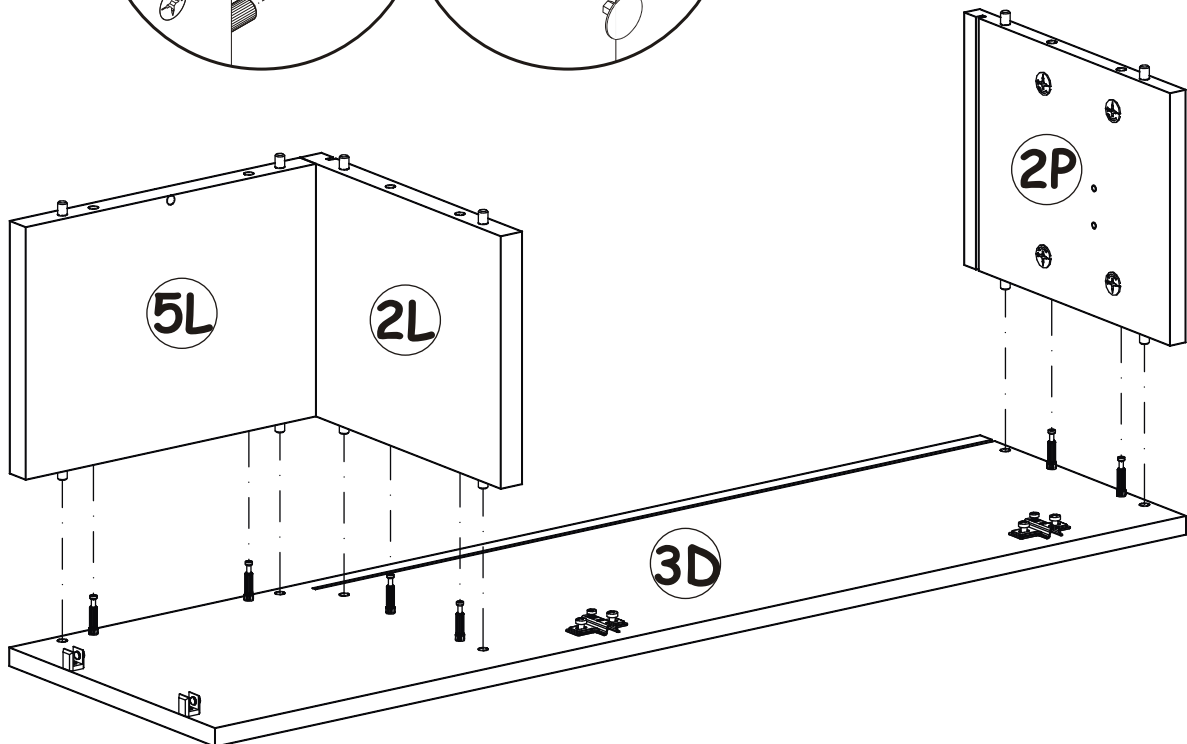

SILK TYP 40

10

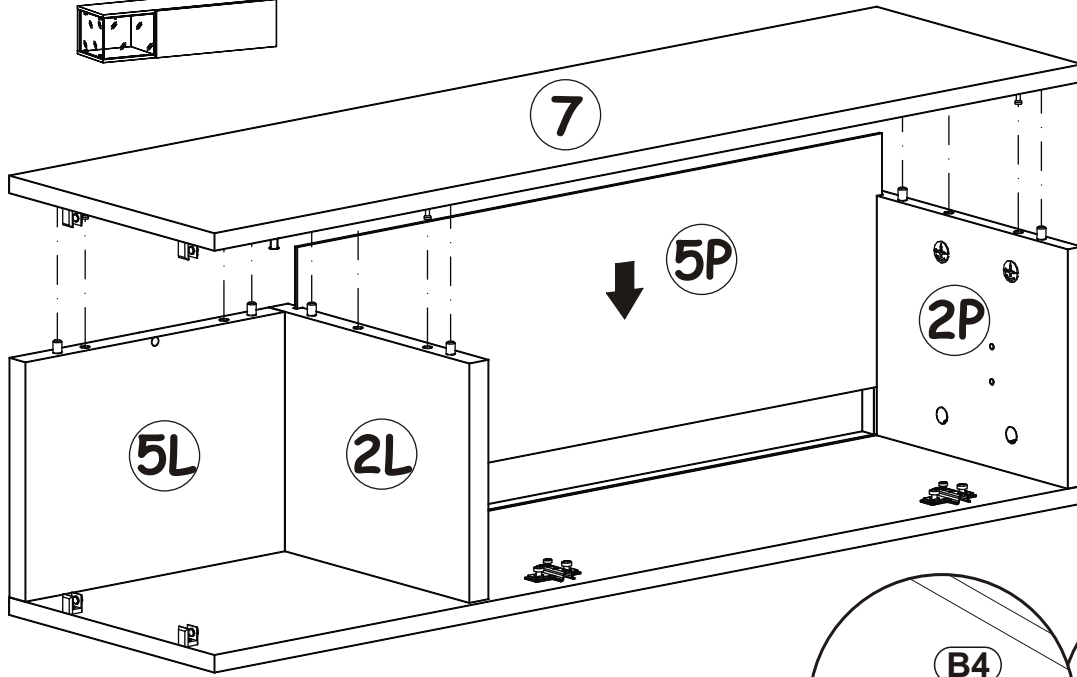
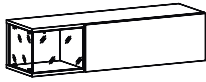

G5

x6

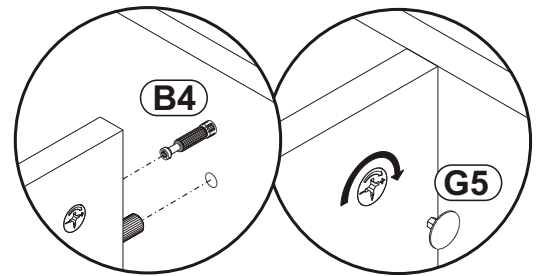
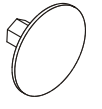

11



$X=Y$ 90°

S1

x6

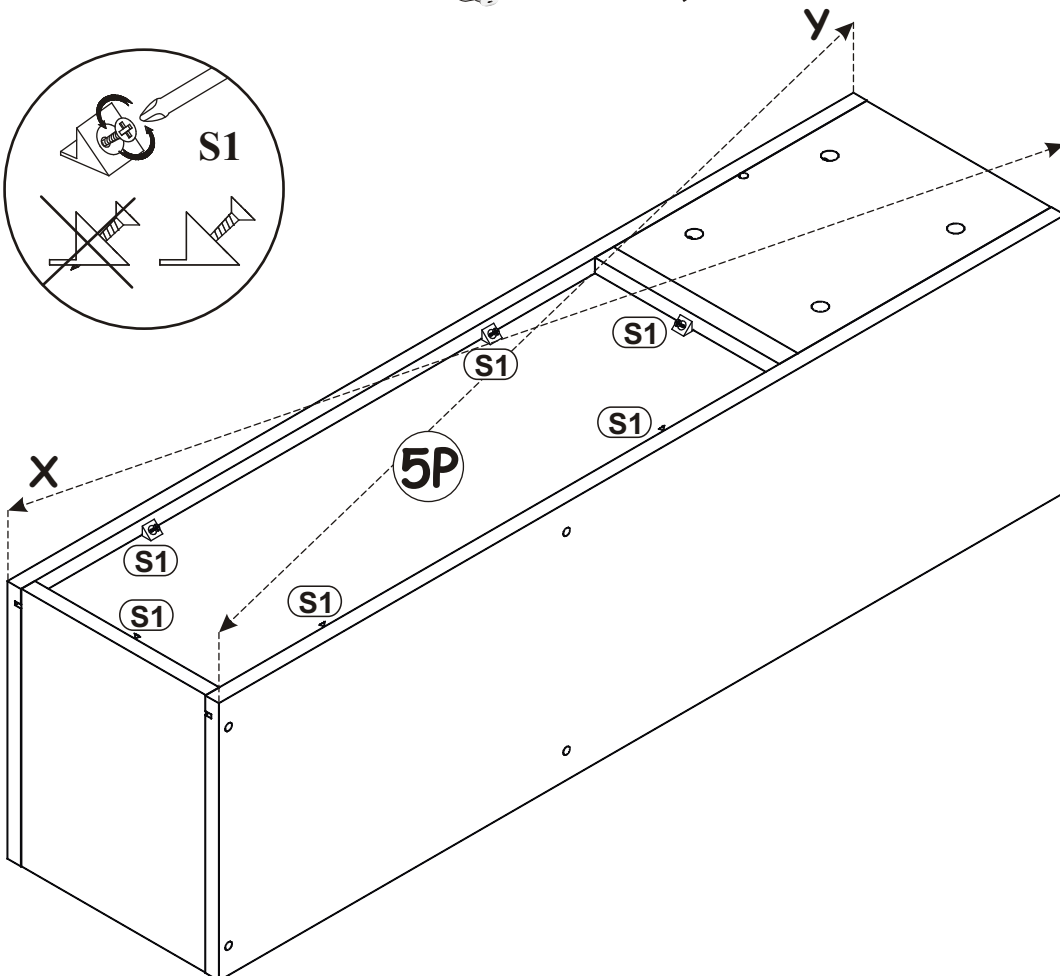
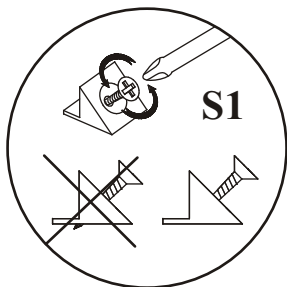
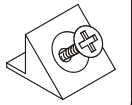

12

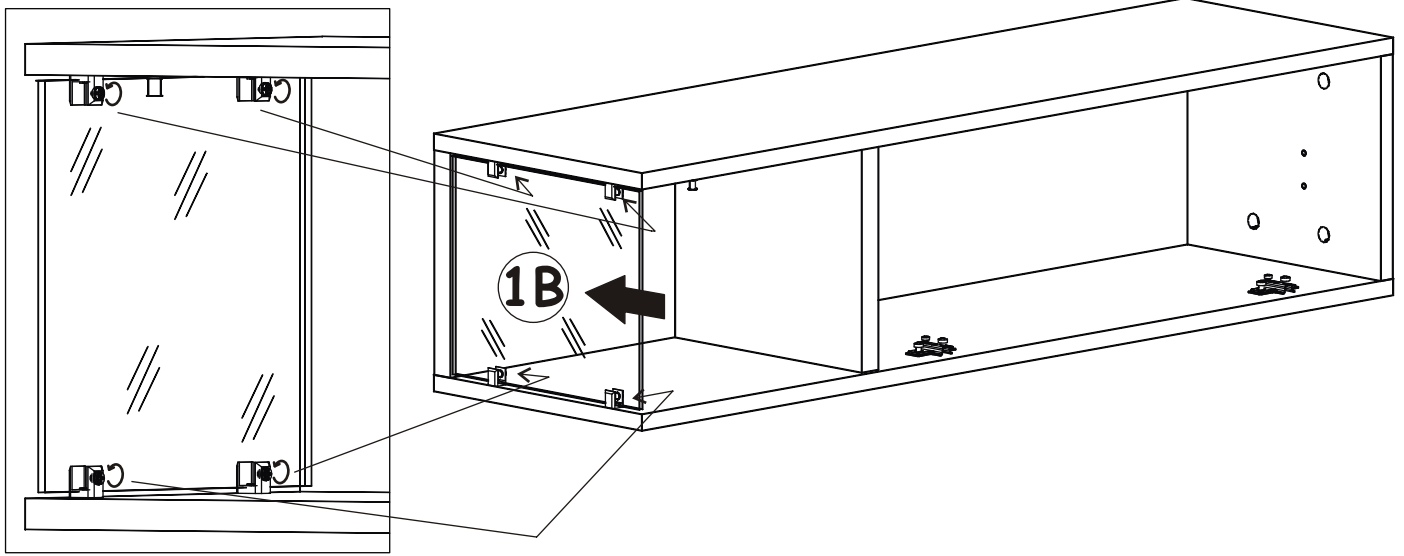
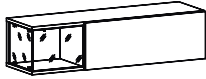

13

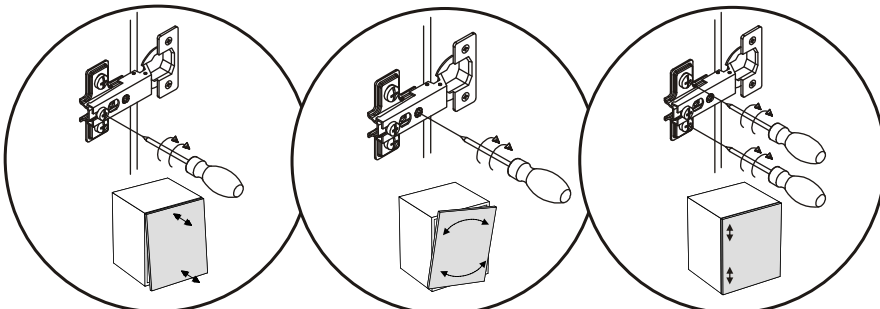
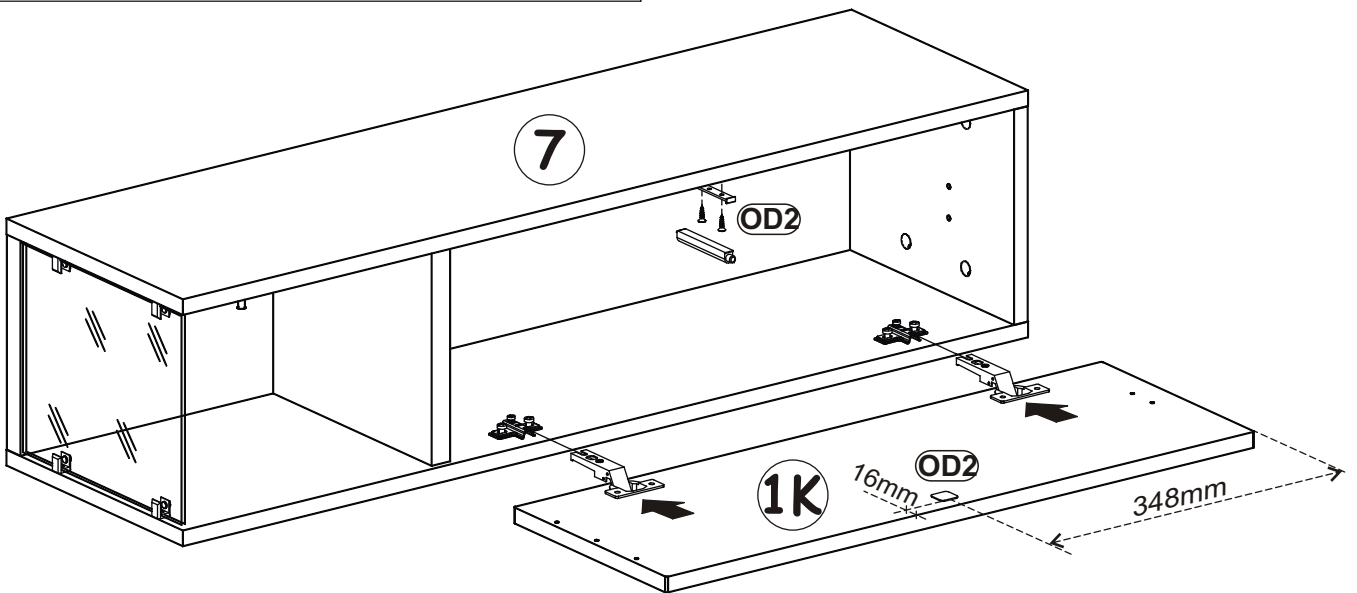
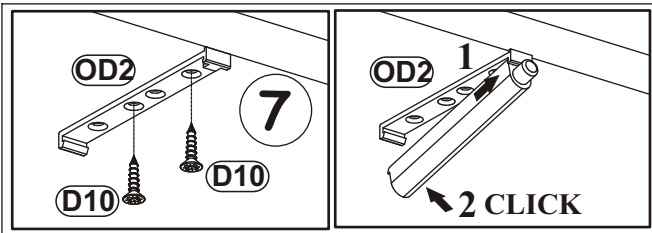
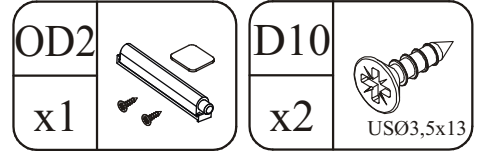

14

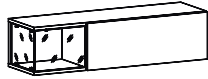

G21	
x1	

D7	
x3	USØ3x16

D10	
x3	USØ3,5x13

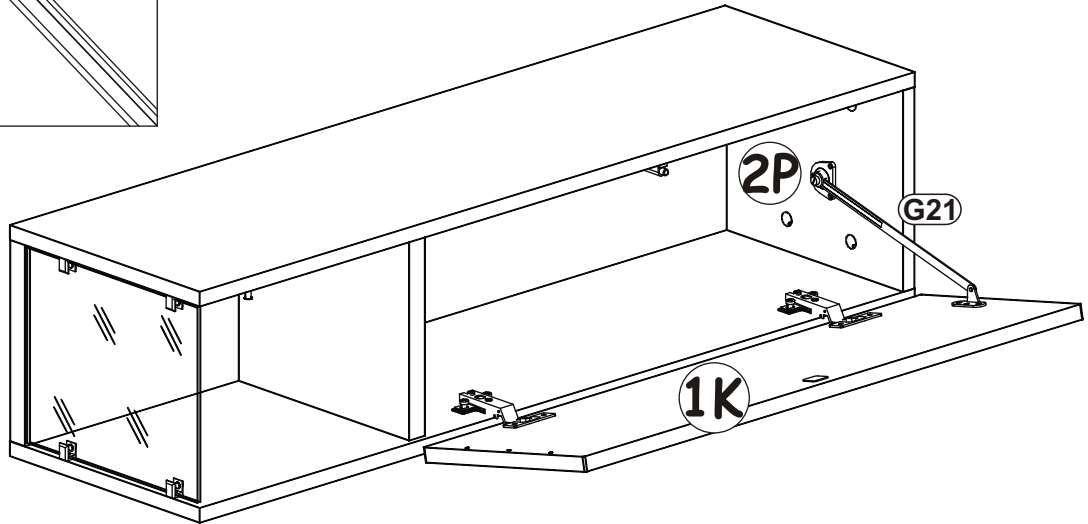
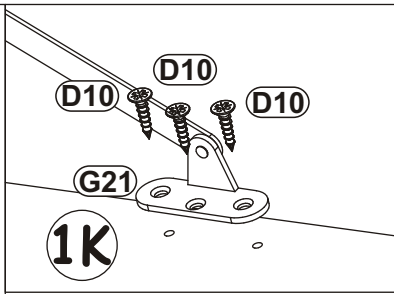
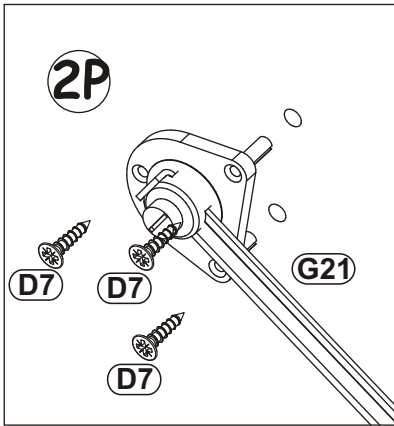

15

P2	
x3	

UP13	
x3	UPØ3x16

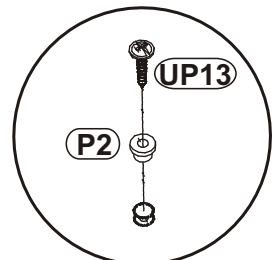
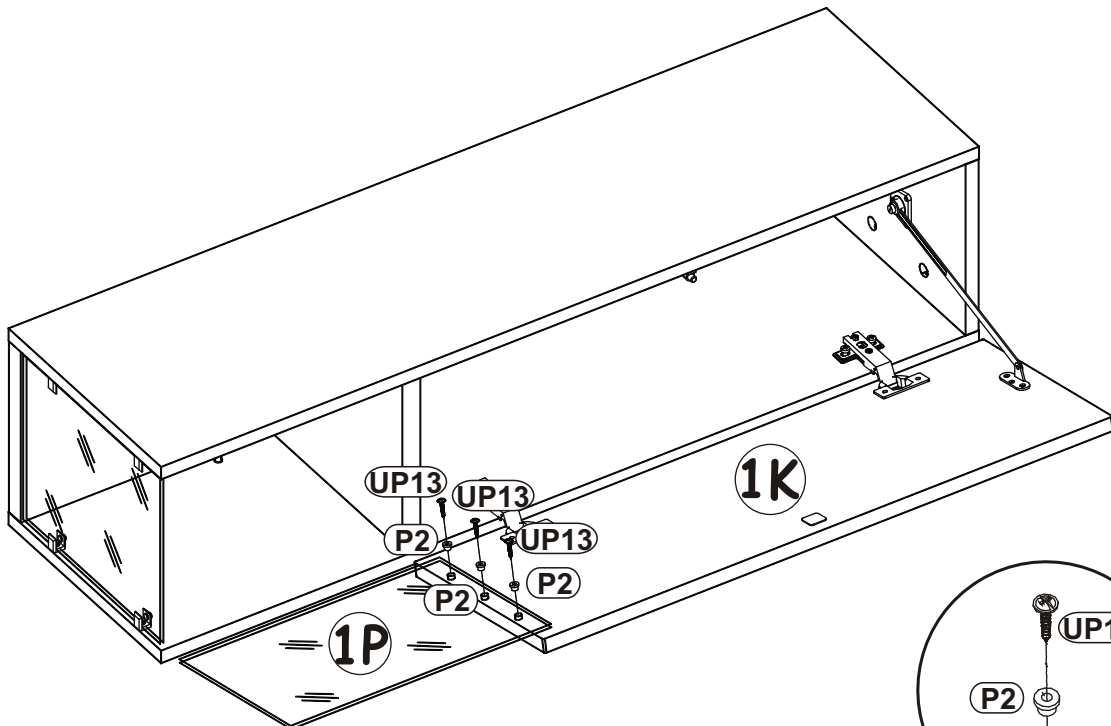

16

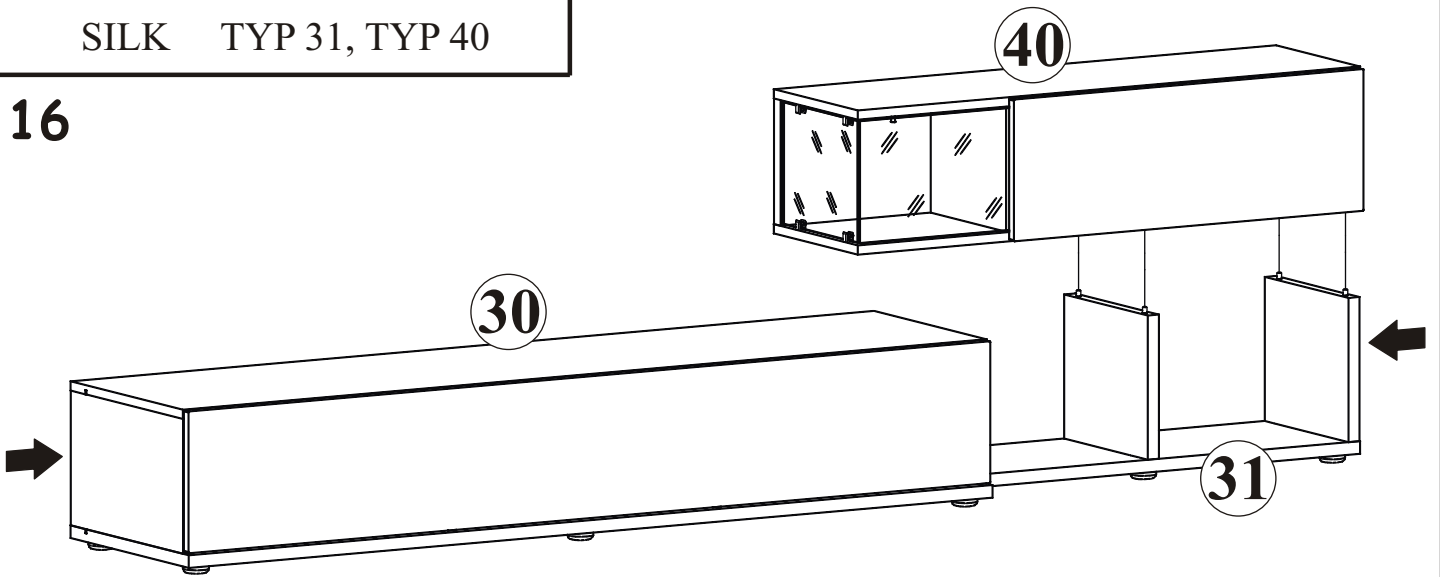

17

