

INSTRUKCJA UNIWERSALNA

MULTI /MULTI 23 - 233

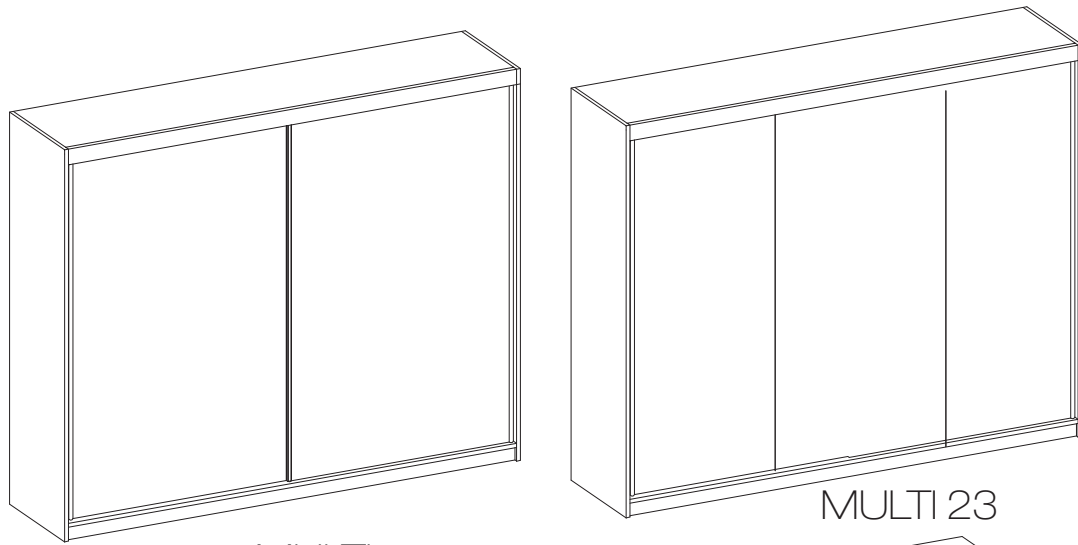

#	ART. NR	QUANTITY
1	401	1
2	402	1
3	403	1
4	101	1
5	102	1
6	201	1
7	202	1
8	203	1
9	204	3
10	001	2
11	801	2
12	501	6
13	601	2
14	350	1

MULTI

MULTI 23

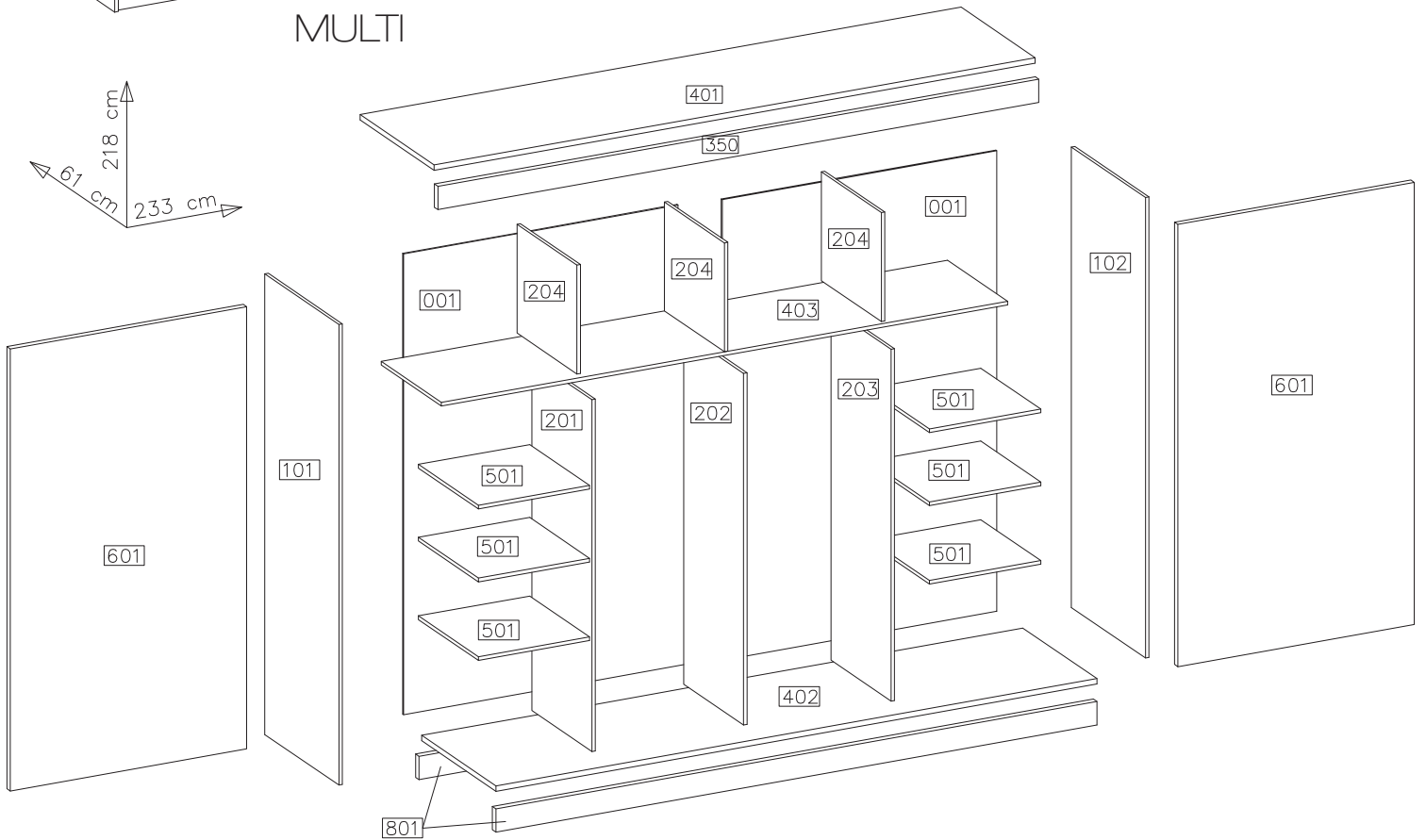
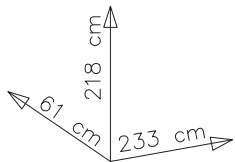





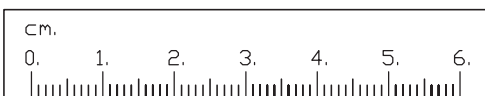

Uchwyt do szafy
MULTI MULTI wrór 23

D1 45	C 45	E 45	A 36	P1 28	S1 4	S1 2	L5 4	K5 MULTI 4	K6 MULTI 4	O12 2
F10 60	F1 12	F8 10	O13 4	J4 24	P3 20	P2 16	O11 1	*dotyczy szafy MULTI 23 - dodatkowe sztuki spakowane w paczce nr 6/6		



* prosimy zwrócić uwagę na elementy s1, k5, k6 i ilość wketów.
Szafa MULTI i szafa MULTI 23 różnią się okuciami

1

∅8x30mm	∅15/12mm				
					
A	C	D1	F1	P3	L5
22	15	15	8	20	4

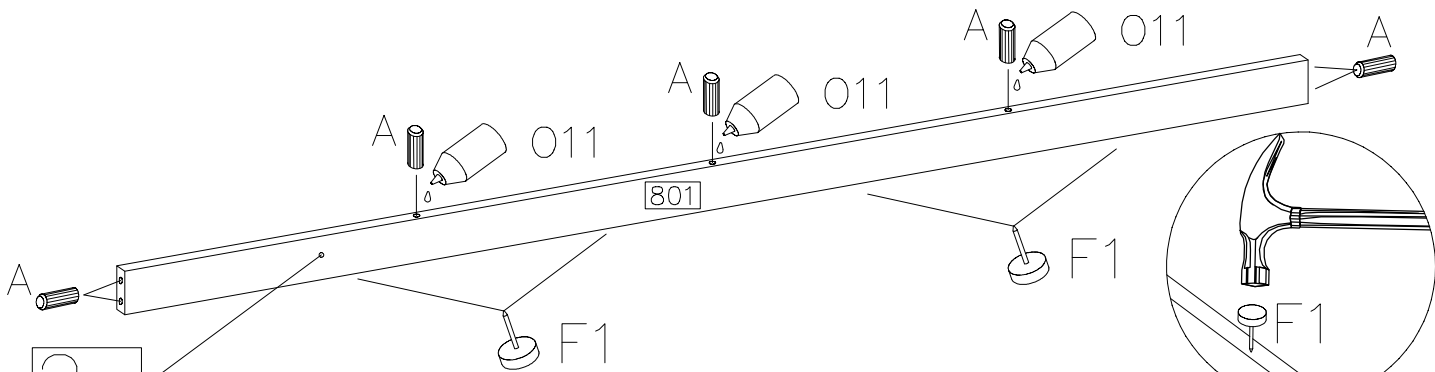
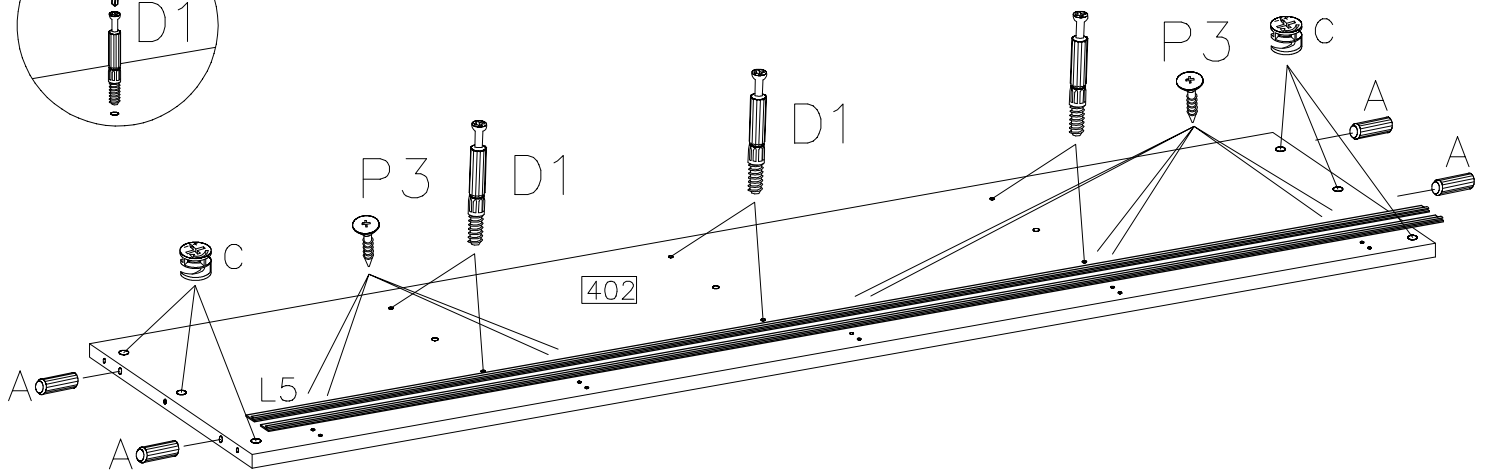
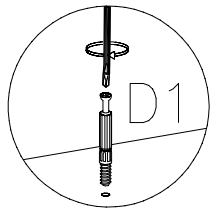
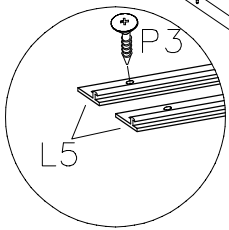
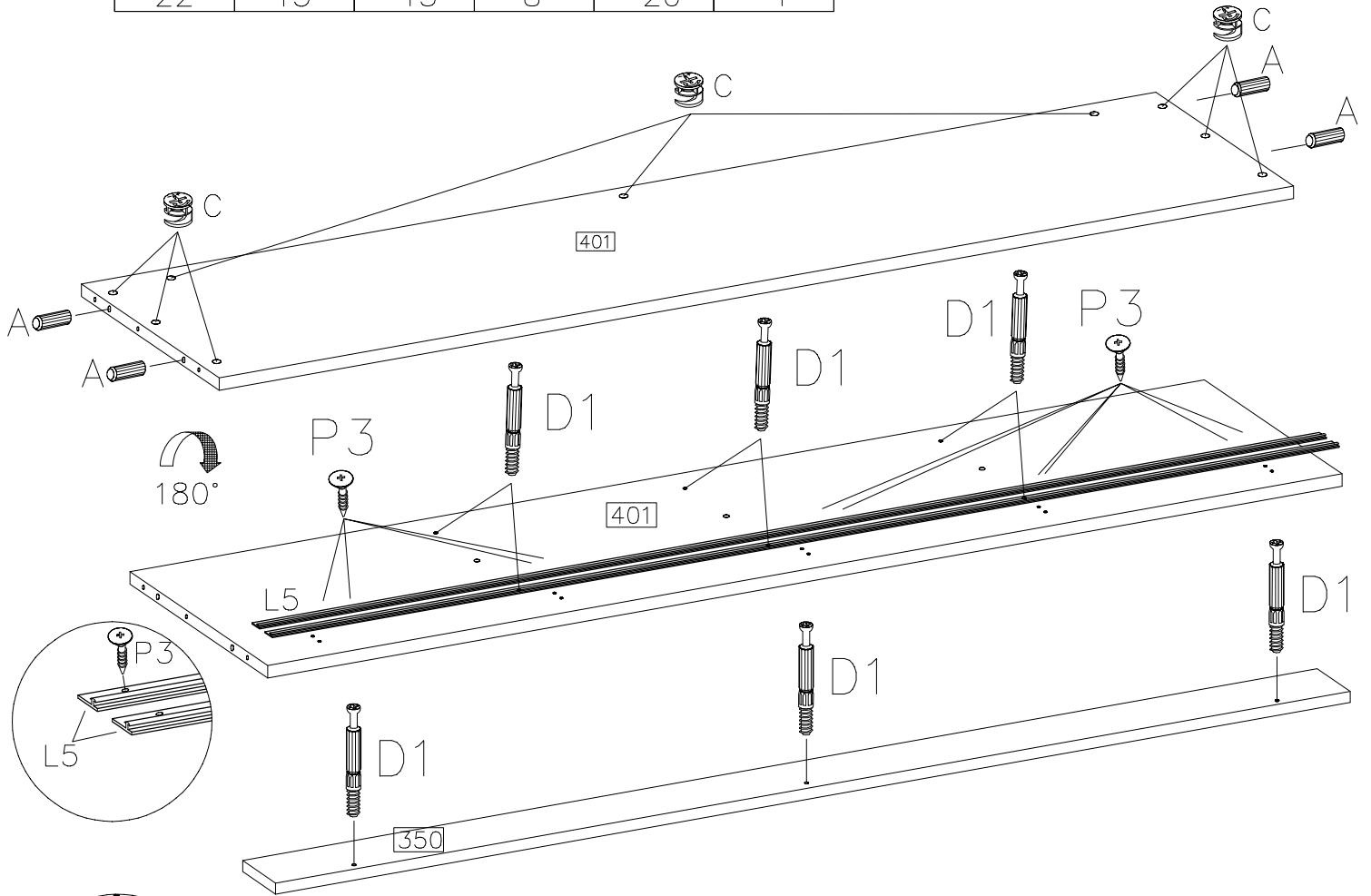

2x

2

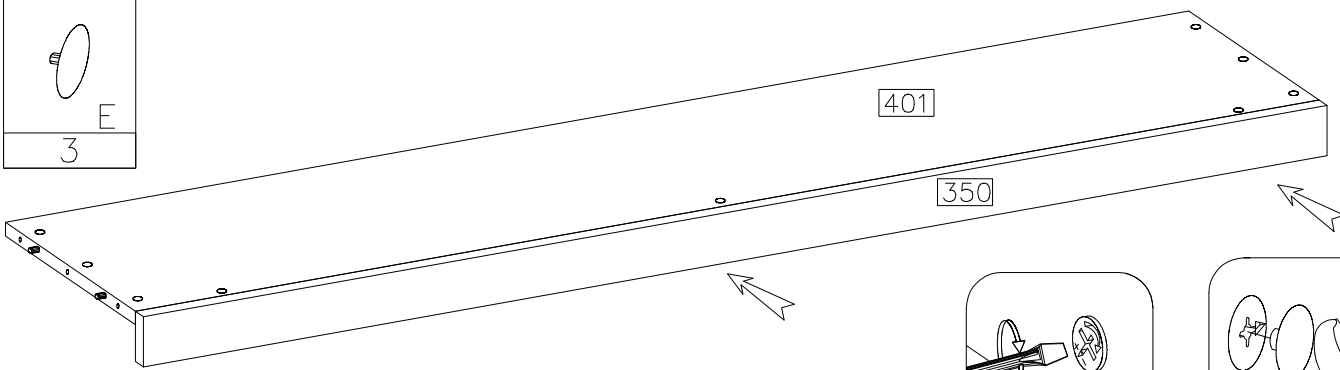
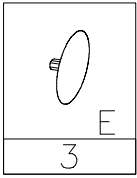

3

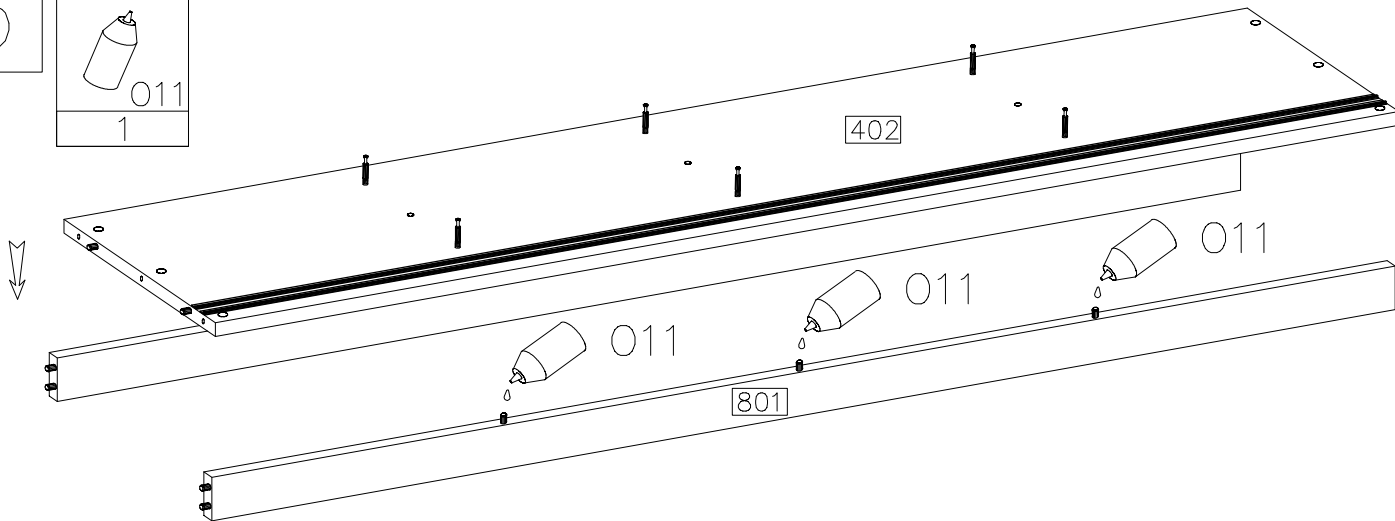
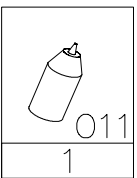



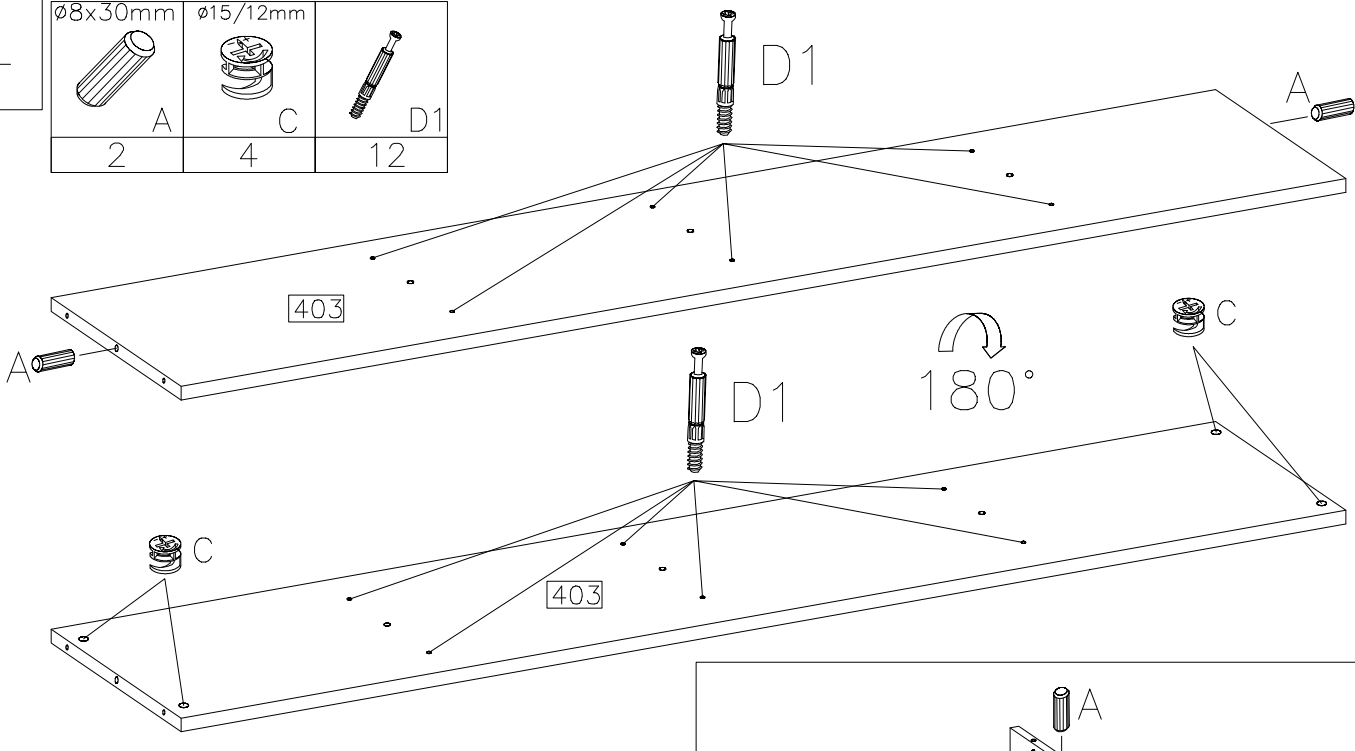
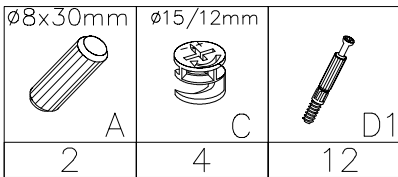

4

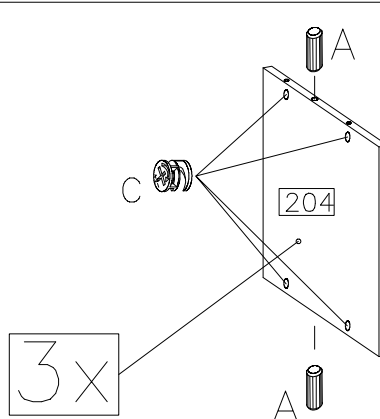
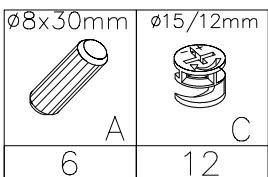

5







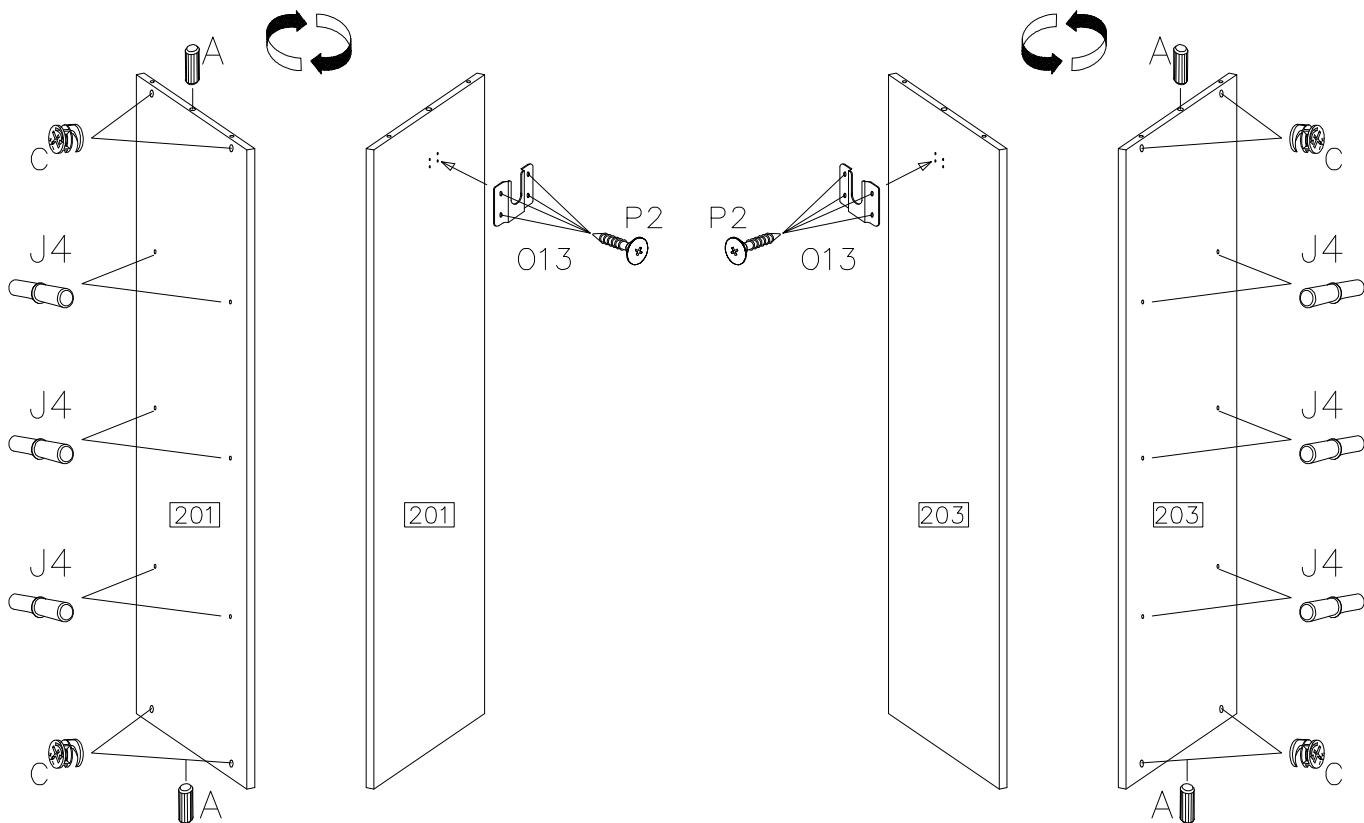

6

$\varnothing 15/12\text{mm}$ 			$\varnothing 8 \times 30\text{mm}$ 	$3.5 \times 13\text{mm}$ 
C	J4	O13	A	P2
8	12	2	4	8



7

			$3.5 \times 13\text{mm}$ 	$\varnothing 8 \times 30\text{mm}$ 	$\varnothing 15/12\text{mm}$ 
J4	D1	O13	P2	A	C
12	16	2	8	2	4

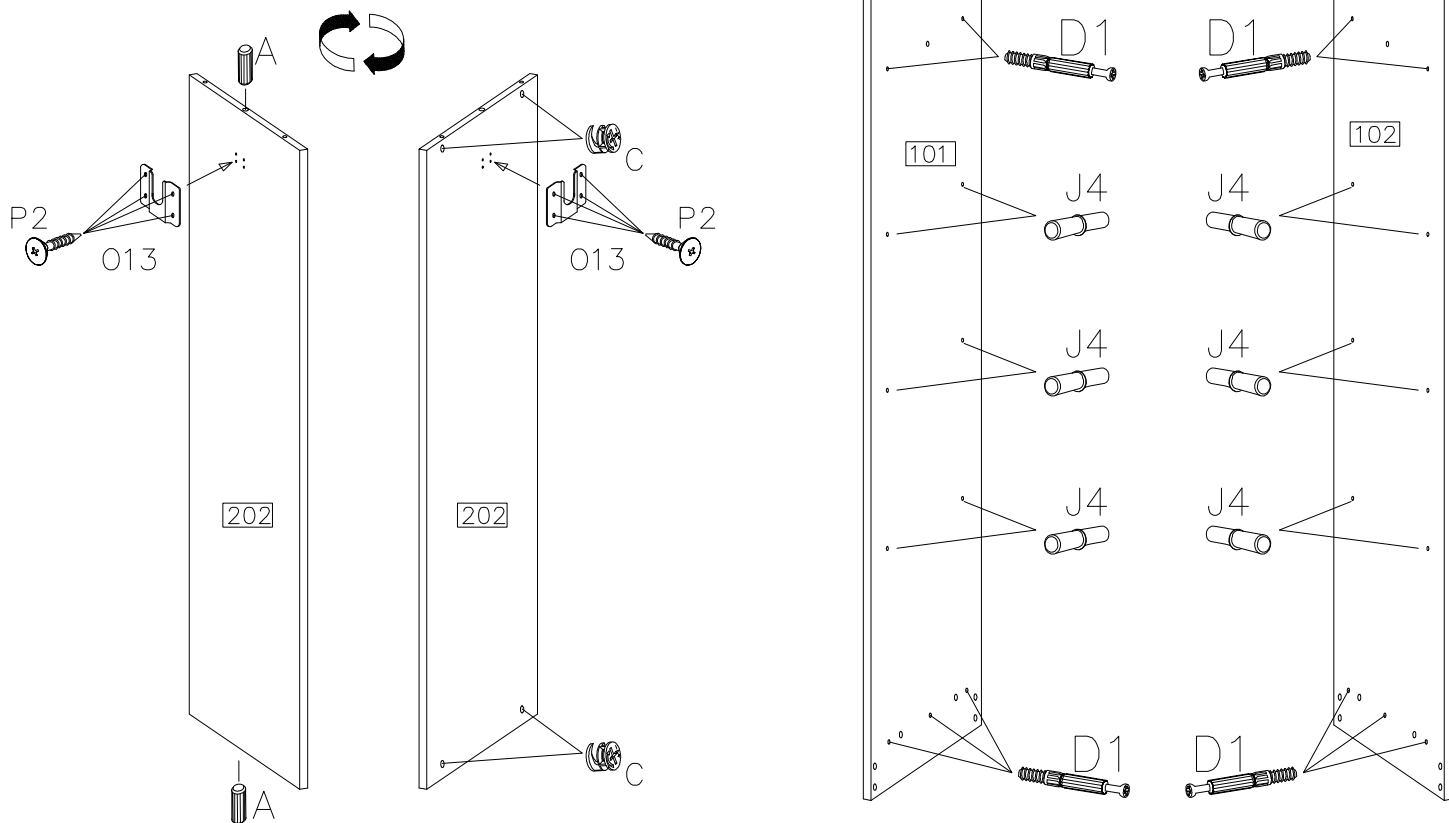

8

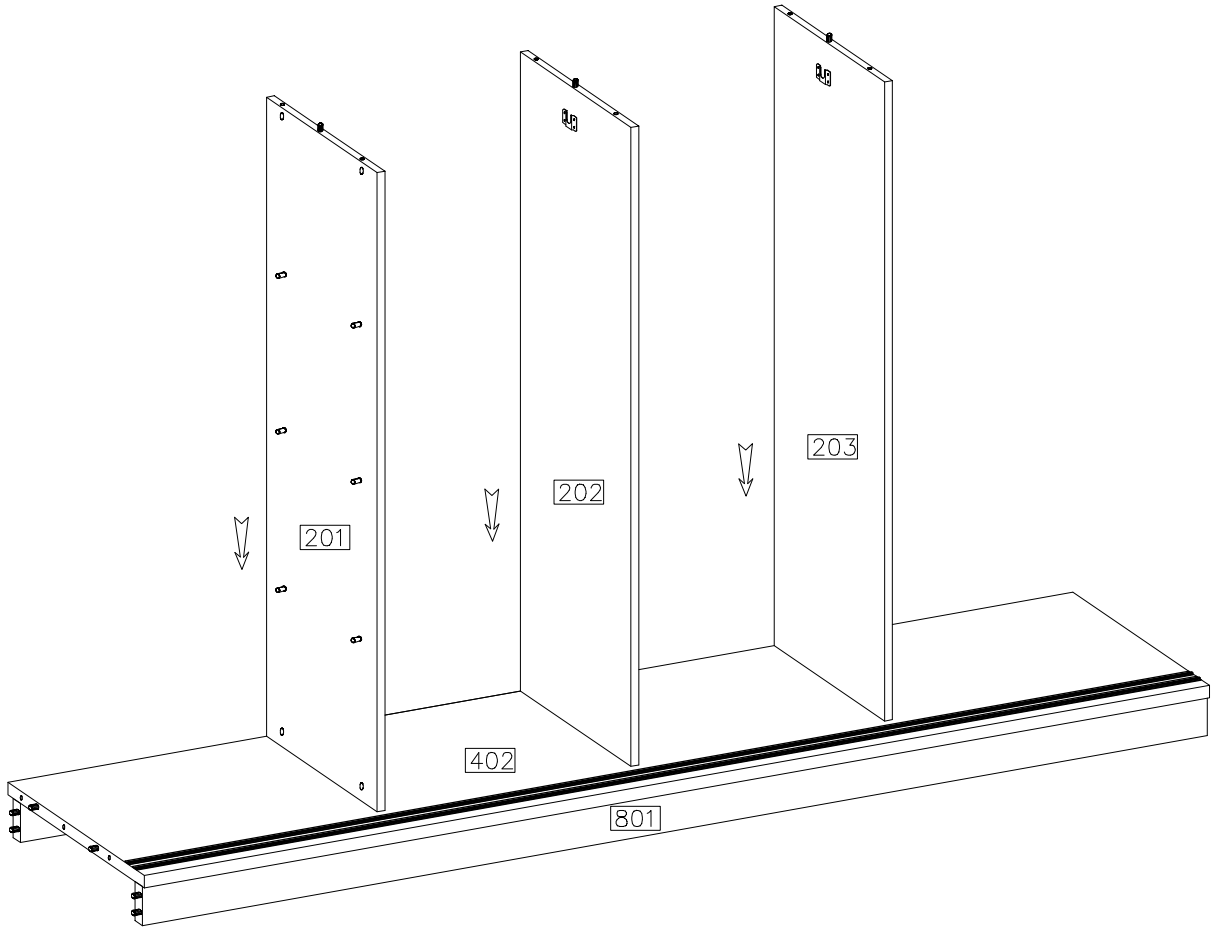
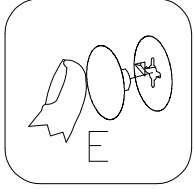
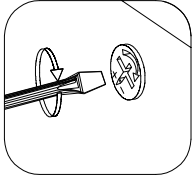
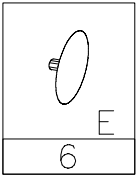

9

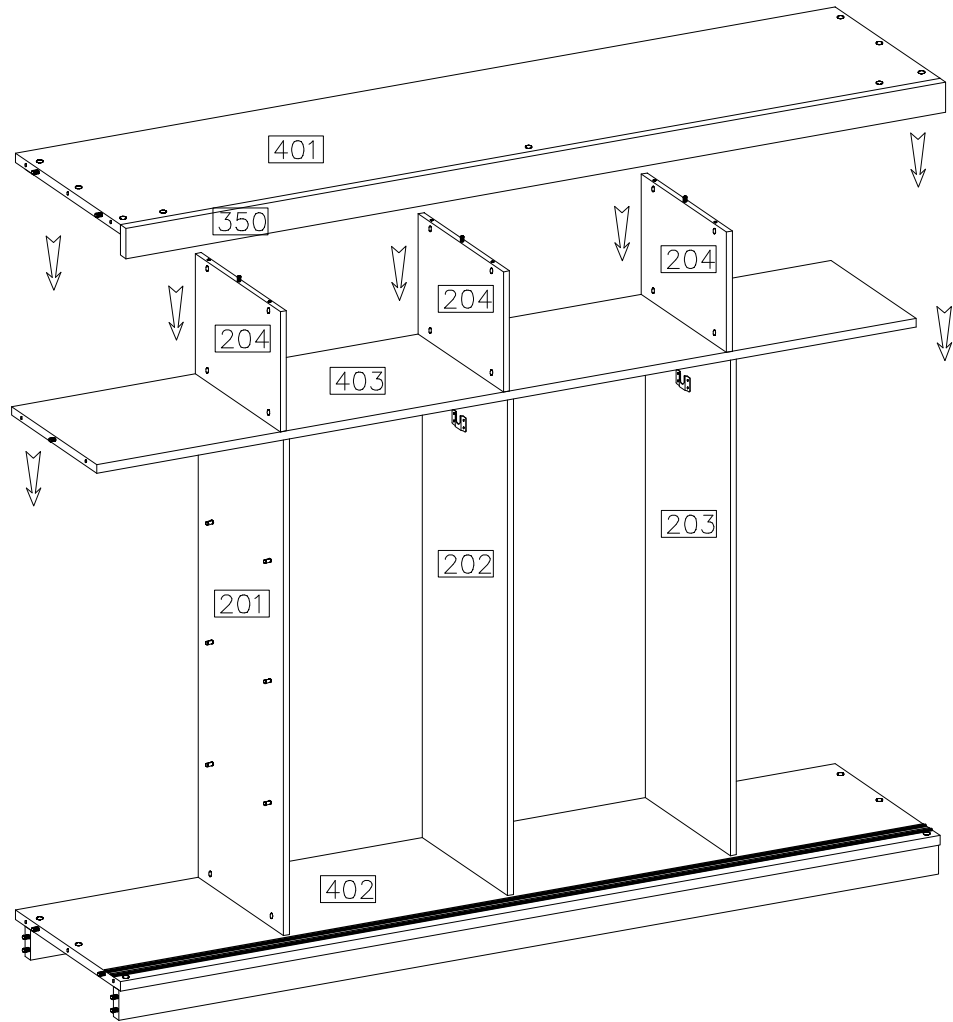
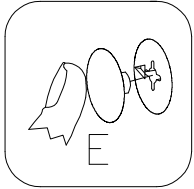
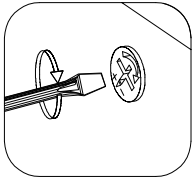
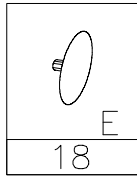

10

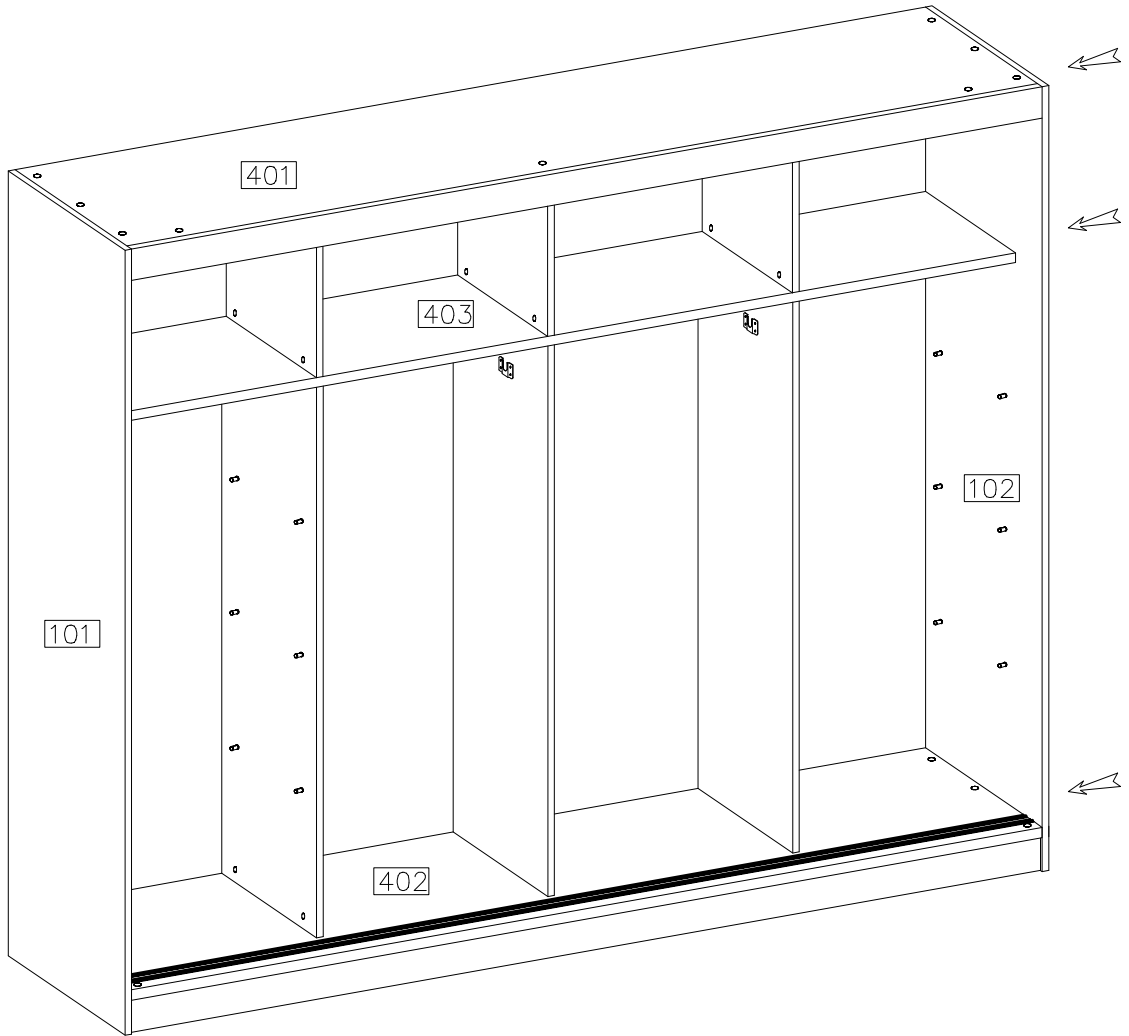
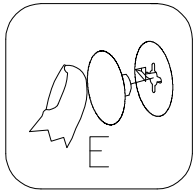
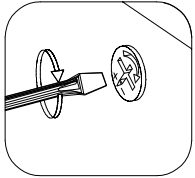
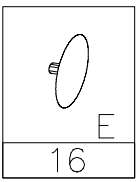



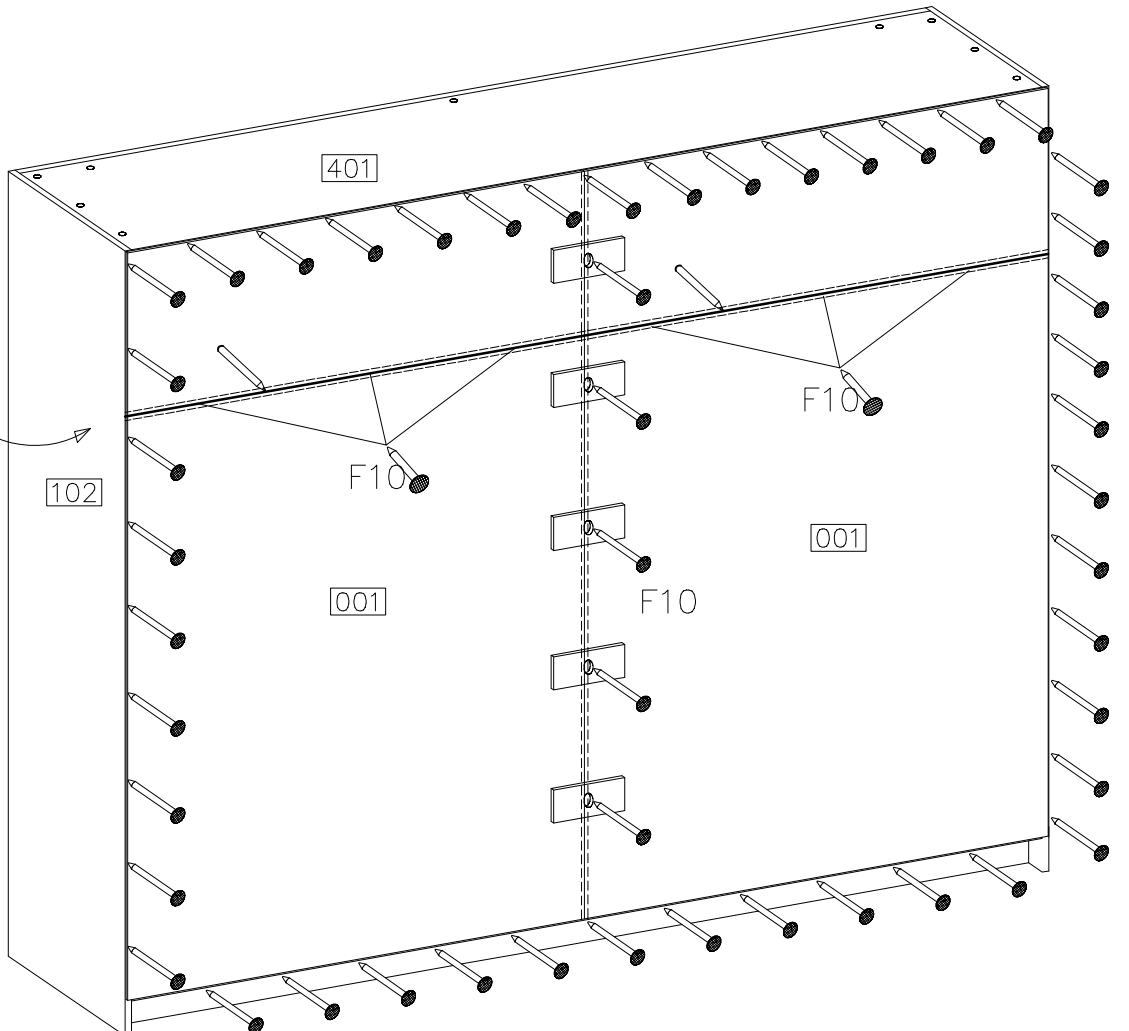
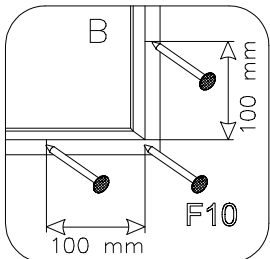
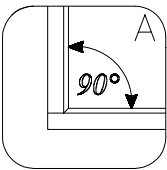
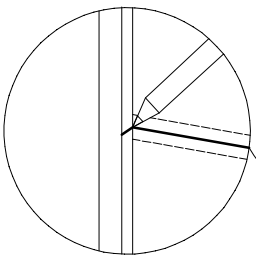
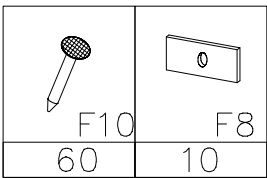

11

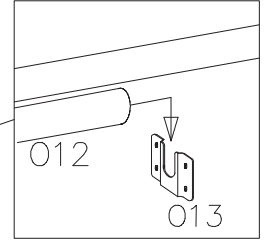
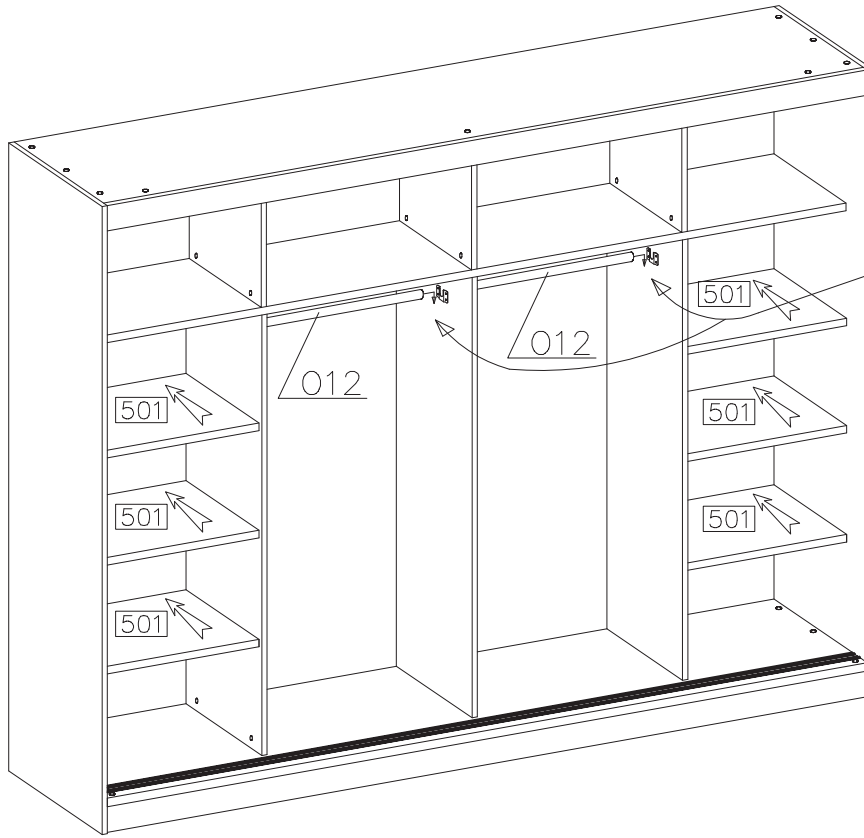
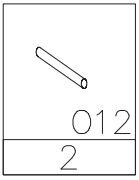

12



13

			 $\varnothing 4.0 \times 16 \text{mm}$	
MULTI	4	4	20	4
MULTI 23	+2	+2	+12	+2

MULTI
MULTI 23

Uchwyt boczny dotyczy szafy MULTI

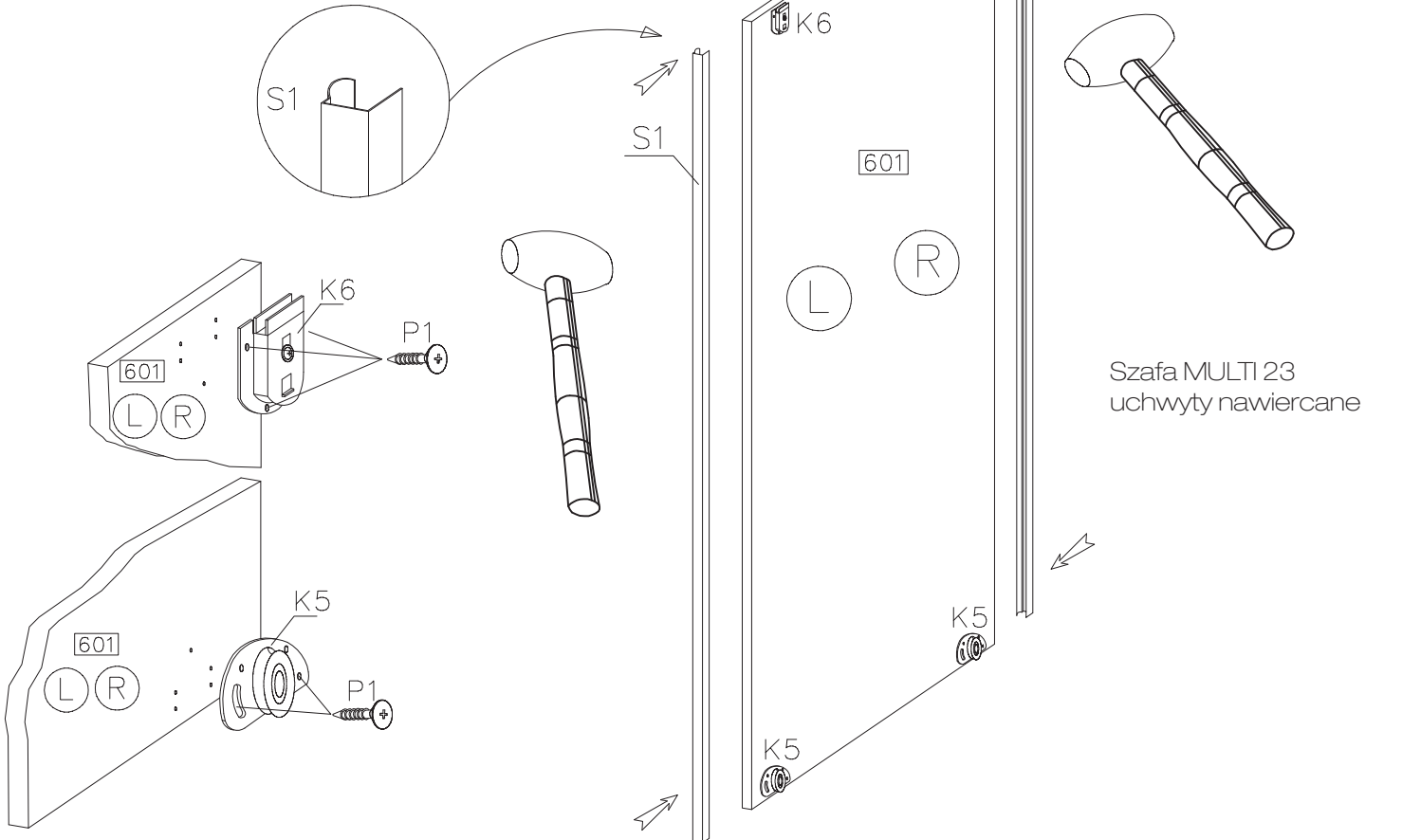

Szafa MULTI 23
uchwyty nawiercane

14

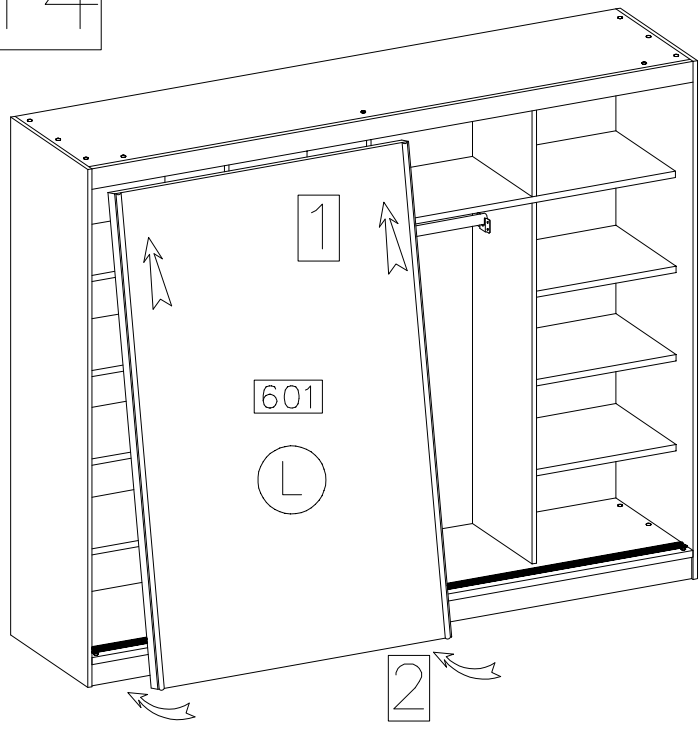

15

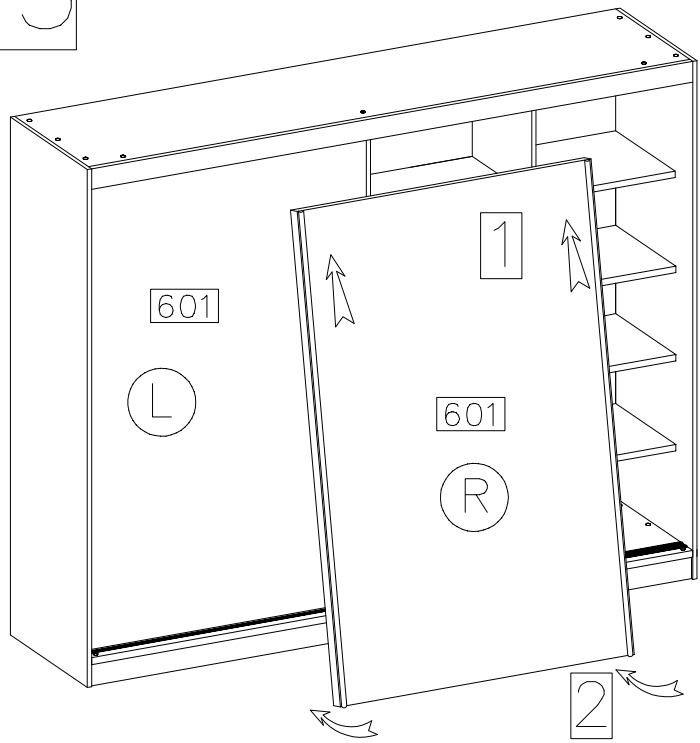

16

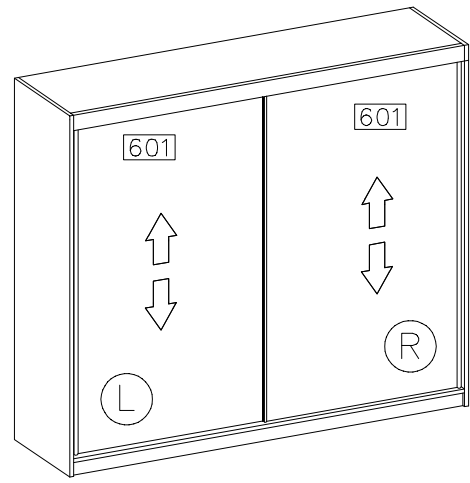
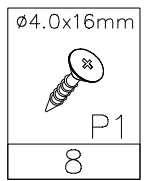

STEP 1
KROK 1

STEP 2
KROK 2

STEP 3
KROK 3

