

A	B	C	D
1	S473-0006	483	170
2	S473-0011	516	410
3	S473-0015	410	170
4	S473-0016	410	170
5	S473-0017	483	350
6	S473-1020	1385	399
7	S473-1021	1385	399
8	S473-1022	1385	362
9	S473-2005	1000	400
10	S473-2006	1000	400
11	S473-3003	482	361
12	S473-3004	465	346
13	S473-3007	466	361
14	S473-3008	465	331
15	S473-3010	481	361
16	S473-5006	1385	72
17	S473-5501	576	390
18	S473-9004	442	357
19	S473-9306	1395	477
20	S473-9307	1395	495
21	ZK3-5142	432	97
22	ZK4-523	350	110
23	ZK4-524	350	110

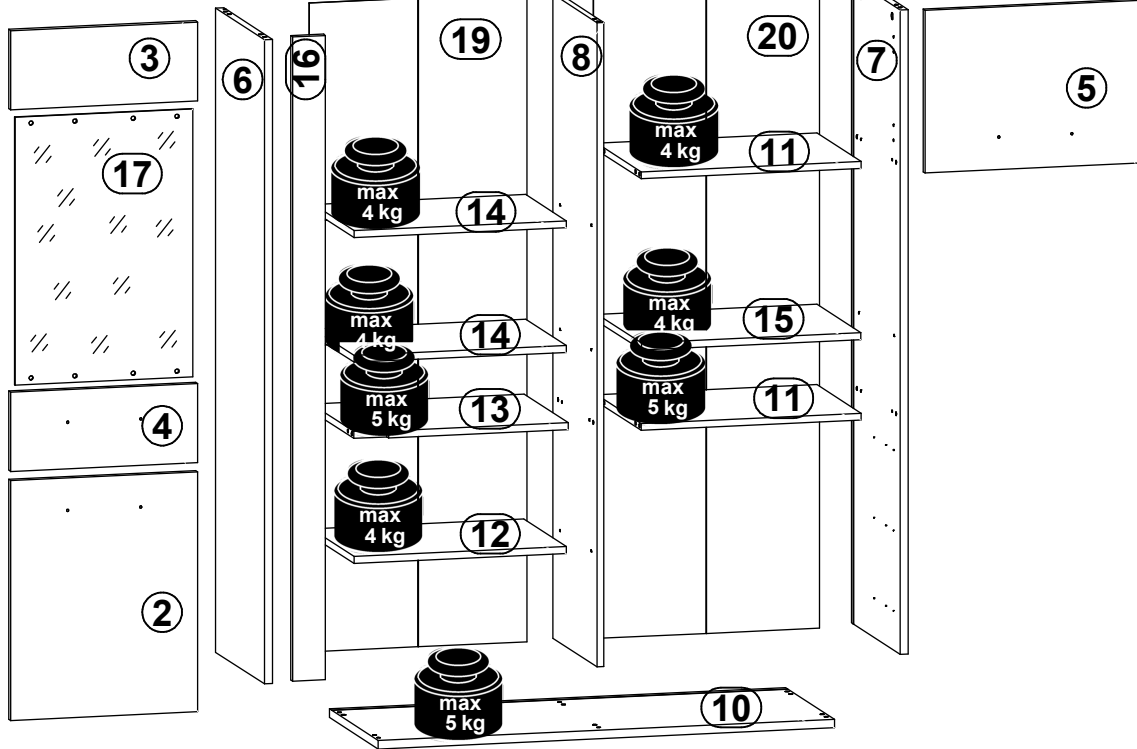

2x a113 Ø35. cichy domyk	2x a176	1x hamulec a203	1x a210	4x b67 H6	2x b90	6x c536v1	16x d1 Ø5x17 mm	5x d41/2
6x e1 Ø7x50 mm	6x e16 Ø6x30 mm	8x e47 Ø5x16 mm	24x f1 Ø8x30 mm	12x f25 Ø6,5x40 mm	6x f9 Ø6x30 mm	28x j173 M5x12 mm	12x j30 M4x22 mm	1x k133/52L
1x k133/52P	2x k133/53	2x k133/56 L-360mm 18x18	2x k133/57 L-360mm 18x18	1x k133/58 L-960mm 18x18	2x k133/59 L-960mm 18x18	10x l2	7x n108 22x9,5x20,7 mm	8x o54 Ø5,3/Ø8,3x4,8 mm
6x o77/16	2x o77/35 10x10 mm L=425 mm	36x p140 Ø3,5x12 mm	6x p15 Ø2,5x13 mm	30x p38 Ø3,5x16 mm	12x p51 Ø3,5x15 mm	11x p55 Ø2,9x16 mm	18x r1 Ø15x12 mm #16	12x r15 Ø12x10,5 mm #12
30x r42	6x w210/1 L=350 mm	6x w210/2 L=350 mm	1x o70 Zasilacz 6W 12V z okablowaniem 4m, wyłącznik nożny, rozdzielacz 3 punkty	10x s68 Ø 20mm	1x z1 4 mm	1x z22 3 mm	1x n26/1	

1 §2

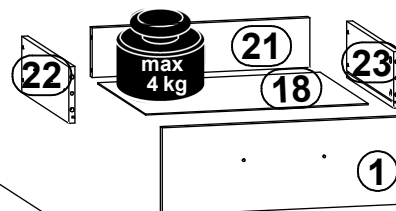
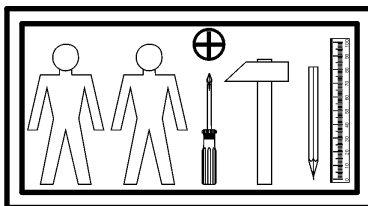
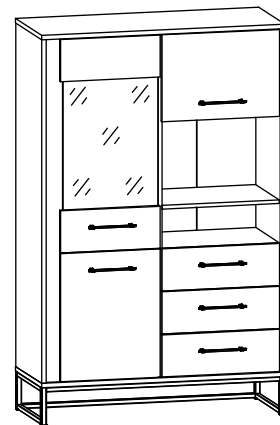
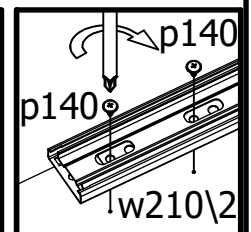
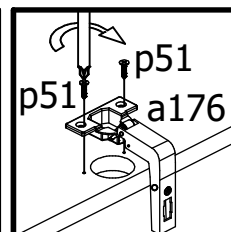
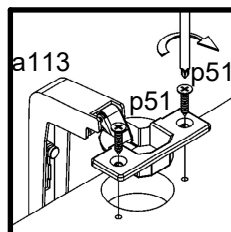
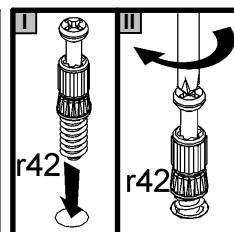
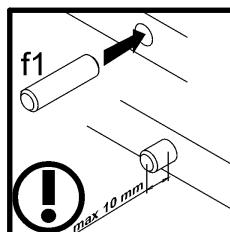
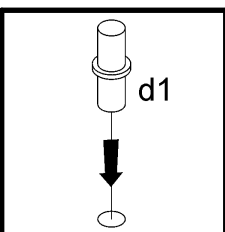
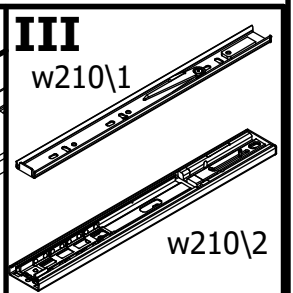
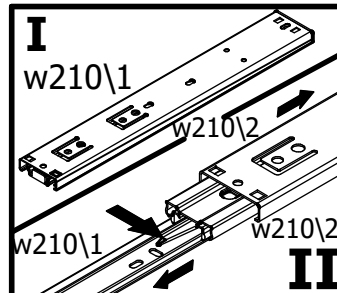
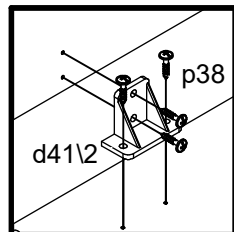
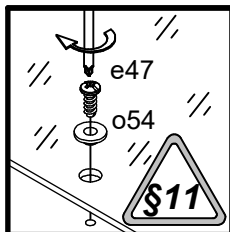
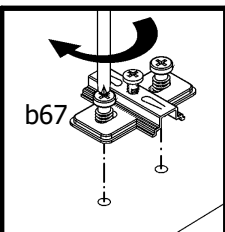
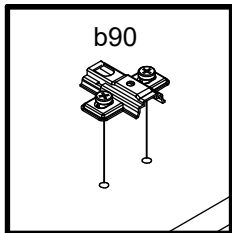
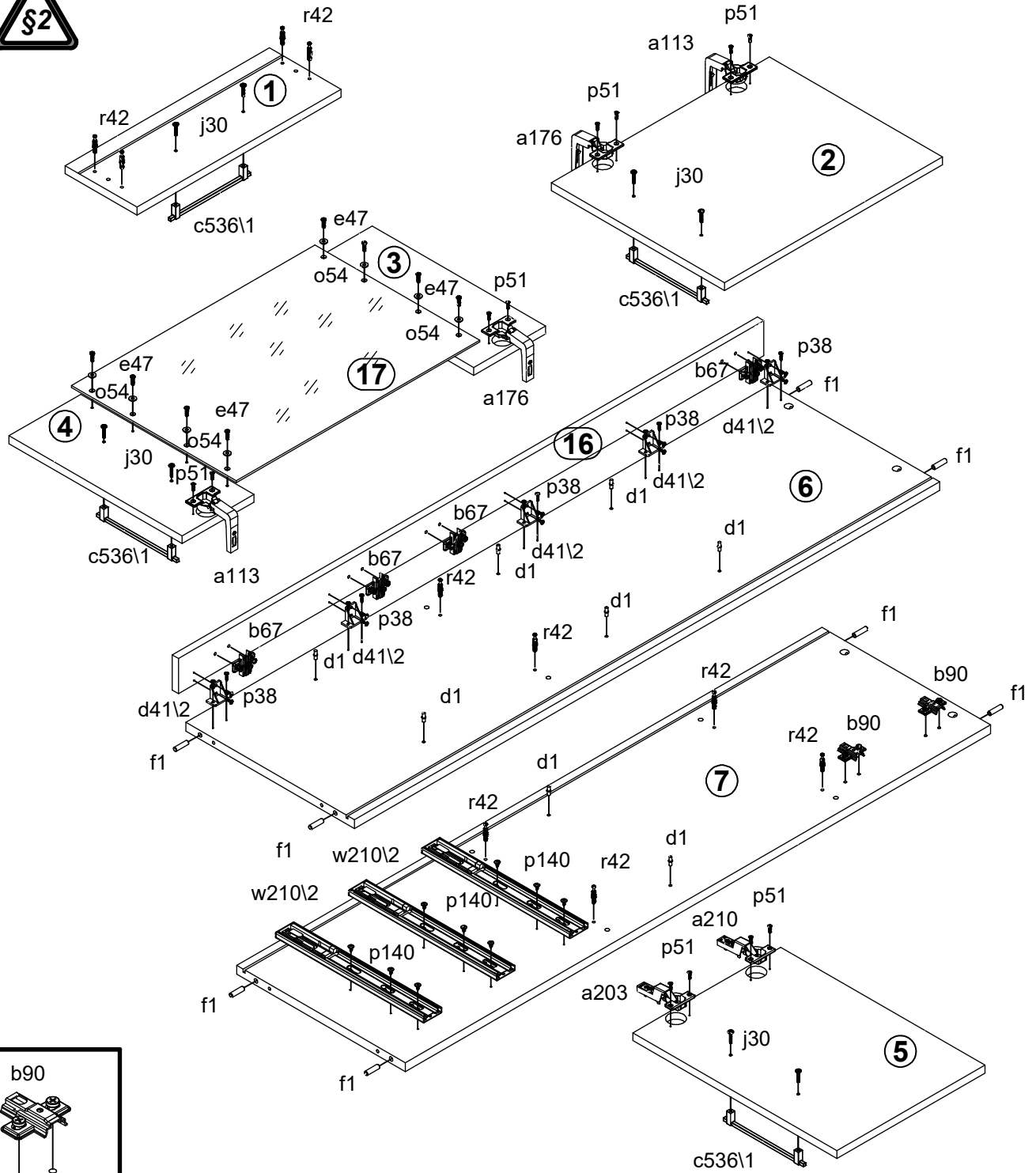

# 2

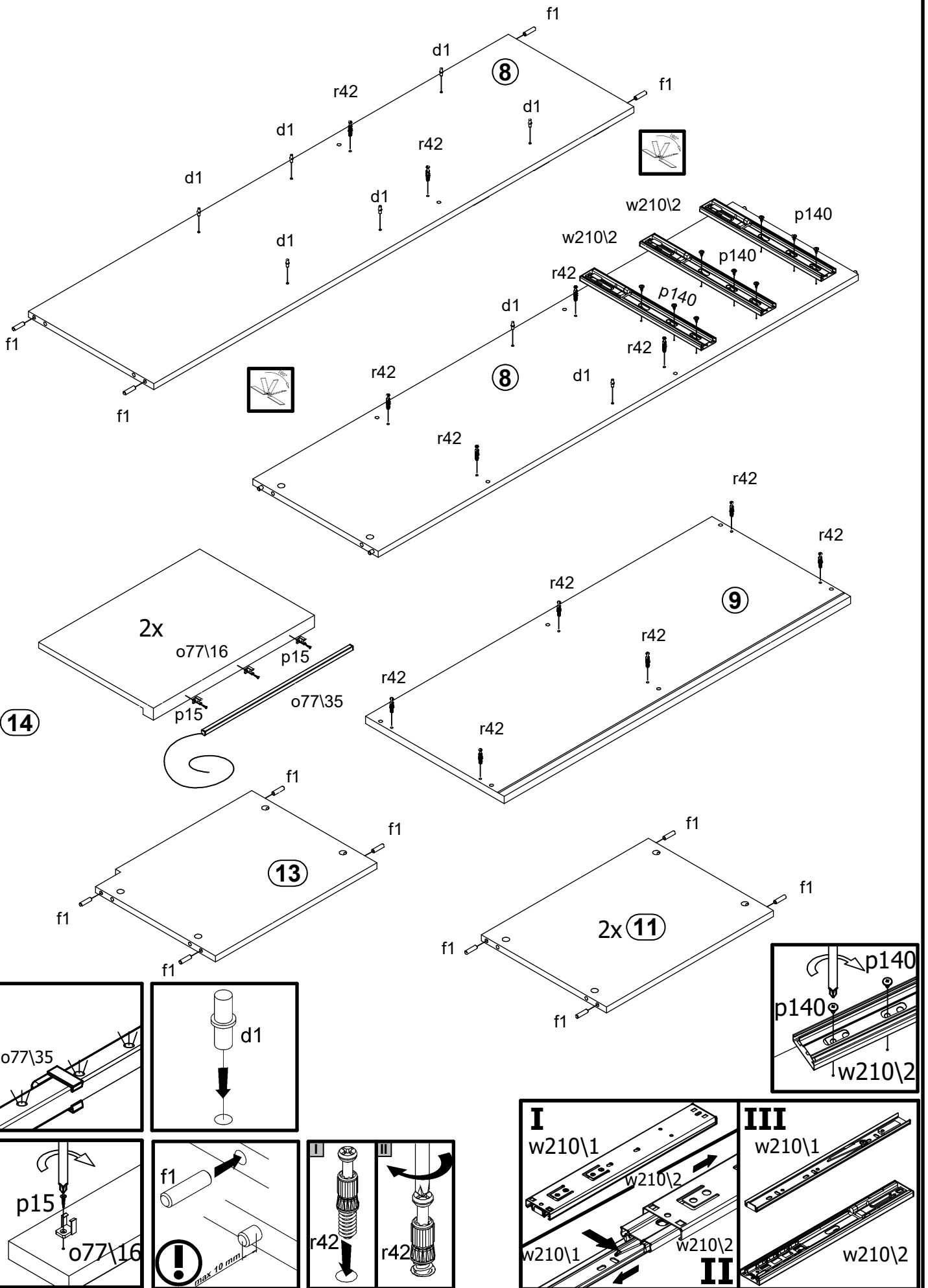

# 3

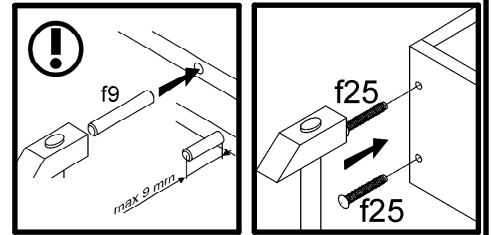
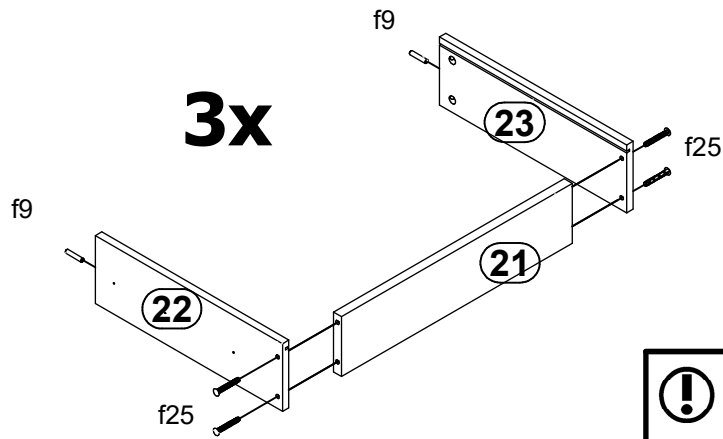

# 4

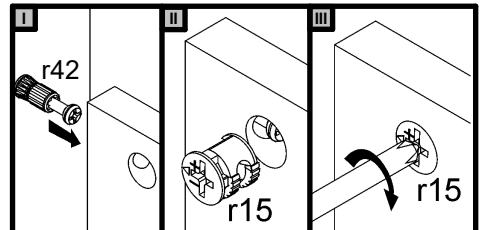
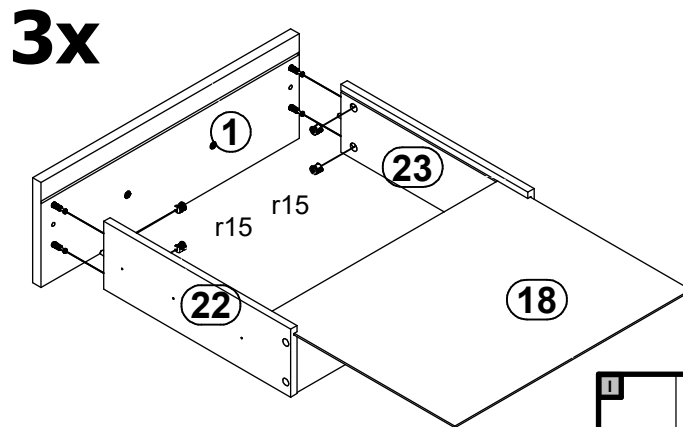

# 5

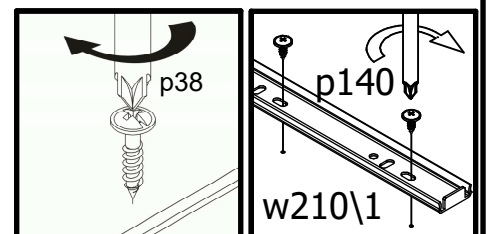
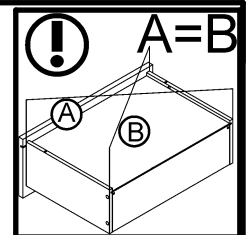
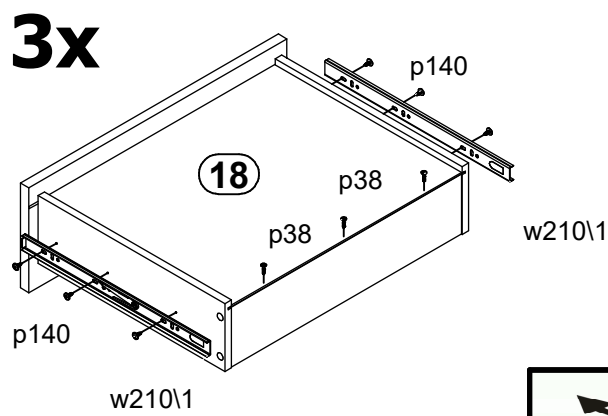

# 6

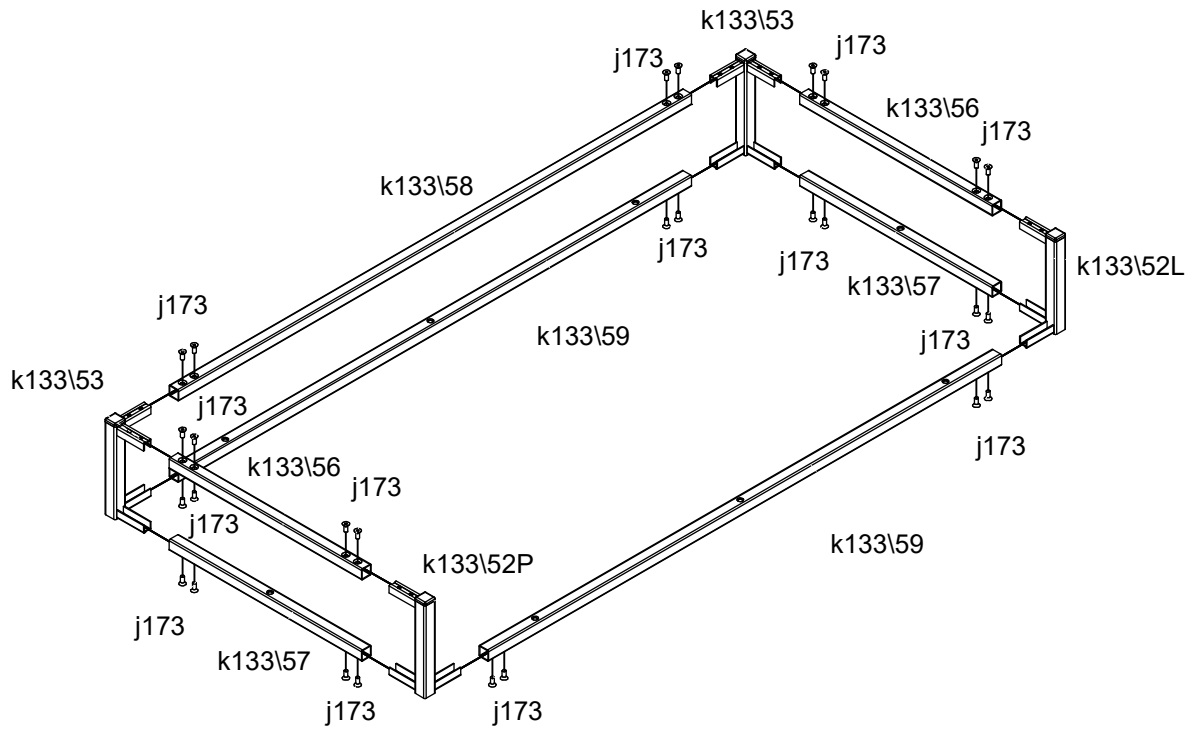

# 7

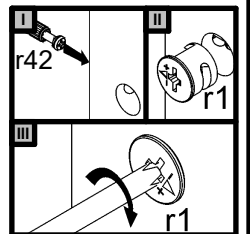
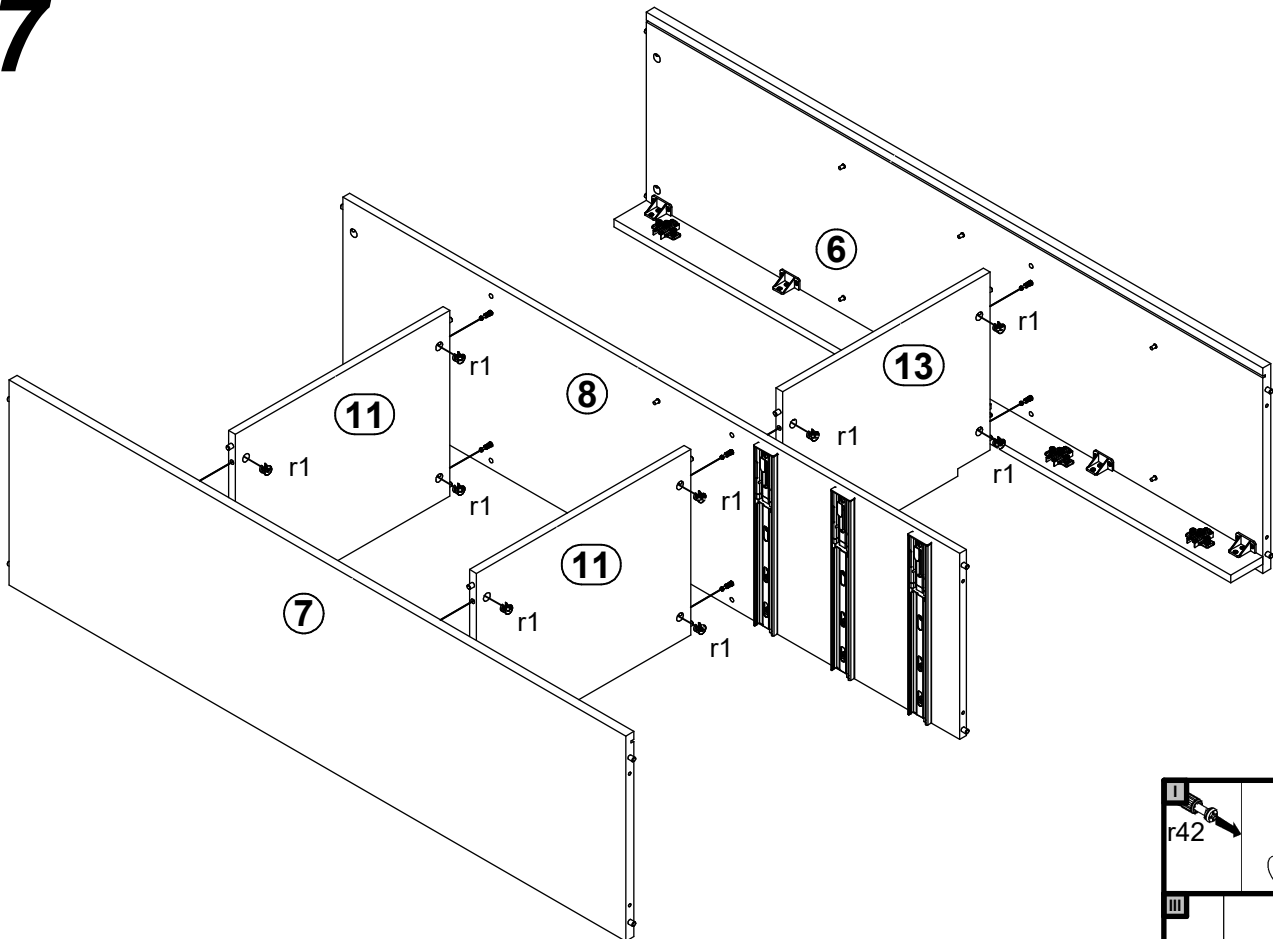

# 8

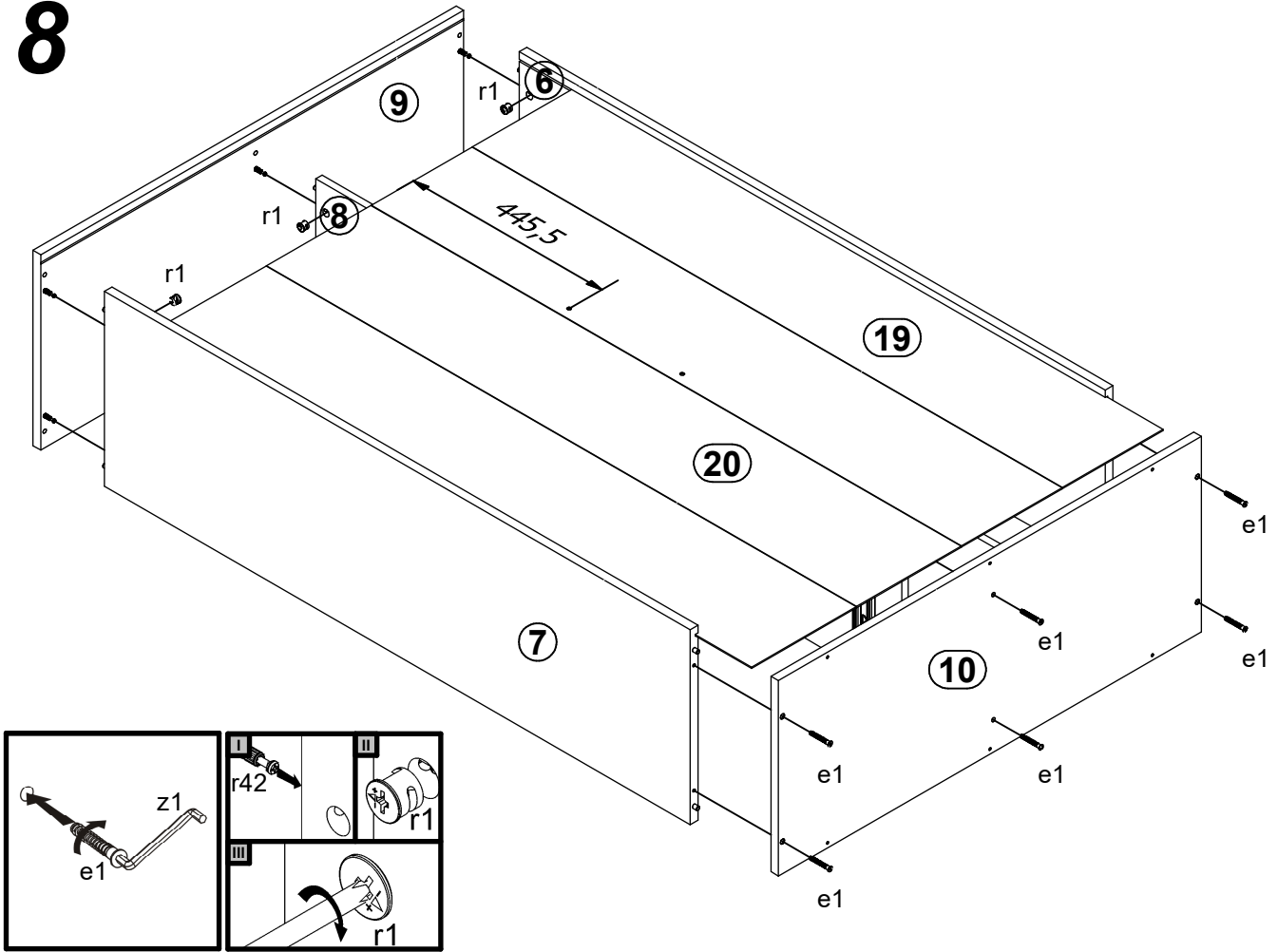

# 9

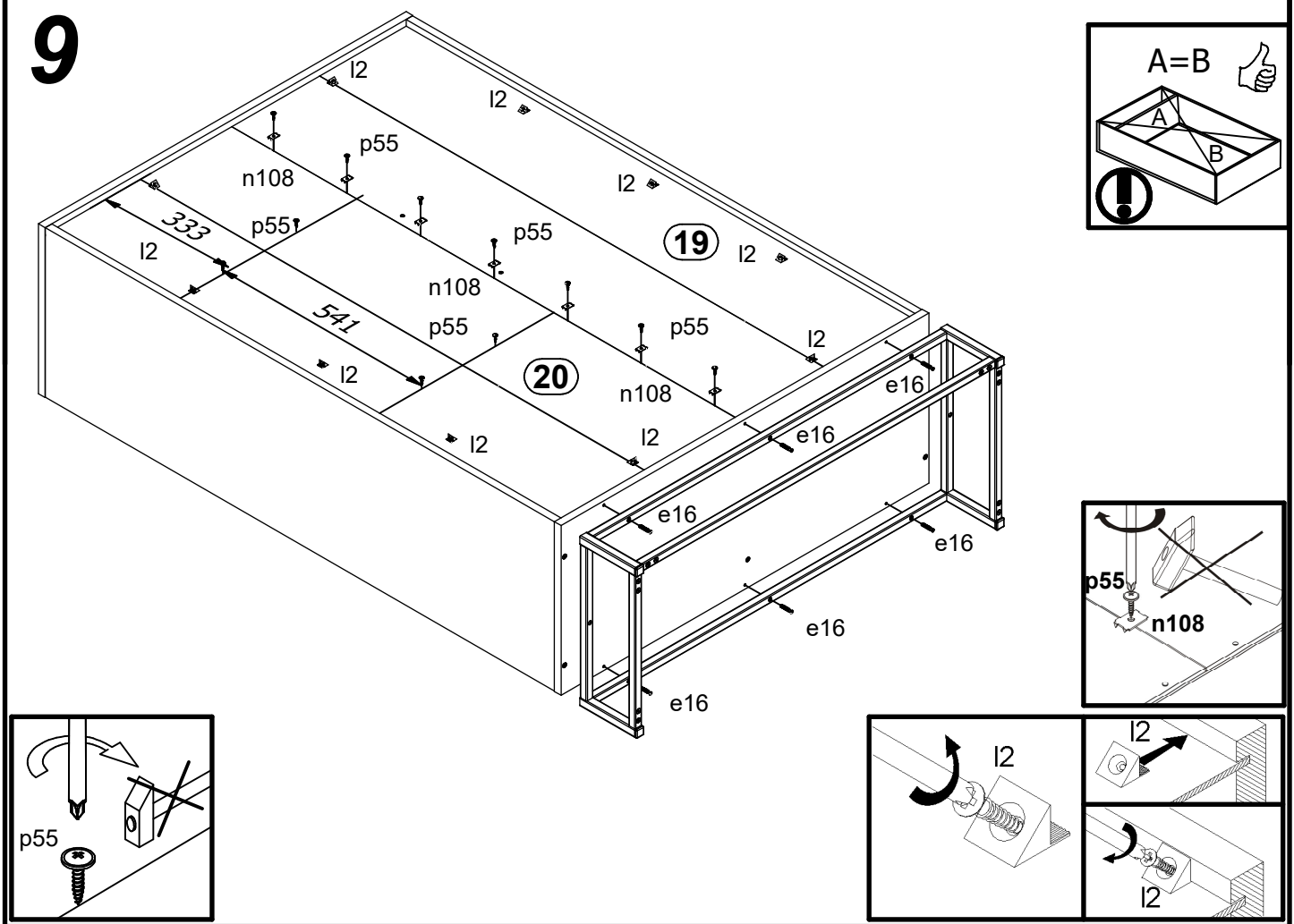

# 10

